

BLQ0070-E01T3A Datasheet



- 70 to 3000 mm travel
- Up to 2.0 m/s speed, 55 N thrust, and 20 kg load capacity
- Integrated recirculating ball bearing guide provides exceptional lifetime
- Integrated, 500 CPR, motor mounted encoder provides slip/stall detection and recovery
- Designed for use with an X-MCC Series stepper motor controller or any 2-phase stepper motor controller
- With AutoDetect, the X-MCC controller configures its settings automatically for the connected peripheral

BLQ-E Series Overview

Zaber's BLQ-E Series products are computer-controlled, motorized linear stages with integrated stepper motors and motor encoders. These stages are capable of speeds up to 2.0 m/s and can easily be mounted in XY configuration without additional hardware. Some multi-axis configurations may require additional accessories; please contact Zaber Technical Support to ensure the correct ones are selected.

The built-in motor encoder allows for closed-loop operation and slip/stall recovery features. The stages are designed to connect directly to our X-MCC Series universal motor controllers, or they can be used with any 2-phase stepper motor controller through the panel mount DB15 connector. Set up is easy with AutoDetect. Once connected, the X-MCC controller will automatically detect and configure the BLQ-E.

For more information visit: <https://www.zaber.com/products/linear-stages/BLQ-E>

BLQ-E Series Part Numbering

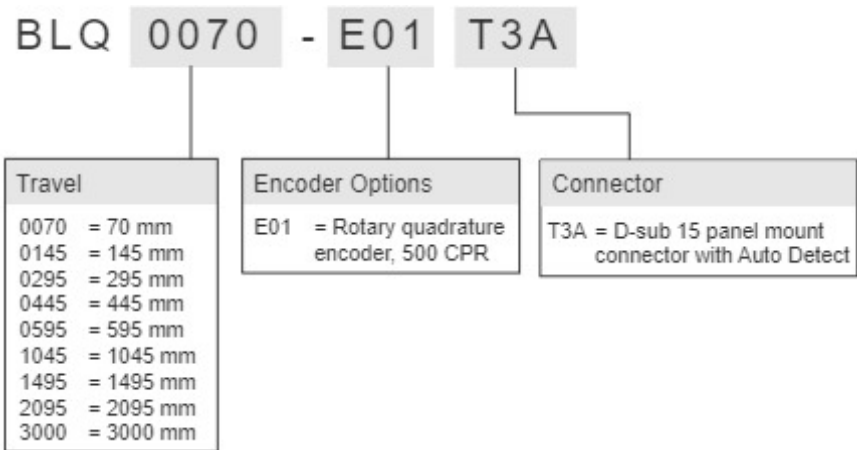

BLQ0070-E01T3A Drawings

ZABER

BLQ-E Motorized Linear Stage
 dimensions in mm

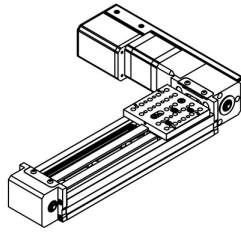

Model Number*	Travel	A	B
BLQ0070-E	70.0	235.2	140.5
BLQ0145-E	145.0	310.2	215.5
BLQ0295-E	295.0	460.2	365.5
BLQ0445-E	445.0	610.2	515.5
BLQ0595-E	595.0	760.2	665.5
BLQ1045-E	1045.0	1212.2	1117.5
BLQ1495-E	1495.0	1662.2	1567.5
BLQ2095-E	2095.0	2262.2	2167.5
BLQ3000-E	3000.0	3168.2	3073.5

*See product page for complete list of available models at www.zaber.com

Mounting slots for M6 or [1/4"-20] screws at 25 mm X 50 mm grid spacing
 *25 mm X 150 mm grid spacing for BLQ1045-E to BLQ3000-E

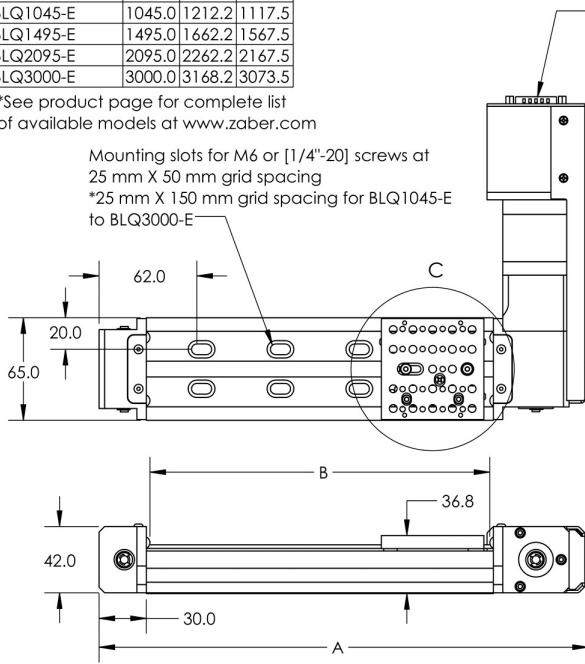

D-sub 15 male connector

22X M6X1.0 ∇ 7.3 at 12.5 mm grid spacing
 17X 8-32 UNC ∇ 7.3 at [1/2"] grid spacing

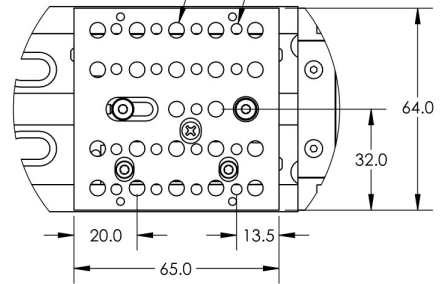

DETAIL C
 SCALE 2 : 3

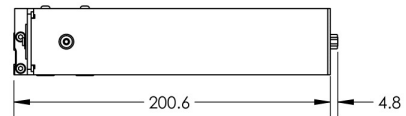

BLQ0070-E01T3A Specifications

Specification	Value	Alternate Unit
Microstep Size (Default Resolution)	4.21875 μm	
Built-in Controller	No	
Recommended Controller	X-MCC (48 V) Recommended	
AutoDetect	Yes	
Travel Range	70 mm	2.756"
Accuracy (unidirectional)	200 μm	0.007874"
Repeatability	< 20 μm	< 0.000787"
Backlash	< 75 μm	< 0.002953"
Maximum Speed	1100 mm/s	43.307"/s
Minimum Speed	0.002576 mm/s	0.000101"/s
Speed Resolution	0.002576 mm/s	0.000101"/s
Encoder Resolution	500 CPR	2000 states/rev
Encoder Type	Rotary quadrature encoder	
Peak Thrust	55 N	12.3 lb
Maximum Continuous Thrust	20 N	4.5 lb
Maximum Centered Load	200 N	44.9 lb
Maximum Cantilever Load	1500 N-cm	2124.2 oz-in
Guide Type	Recirculating Ball Linear Guide	
Vertical Runout	< 30 μm	< 0.001181"
Horizontal Runout	< 20 μm	< 0.000787"
Pitch	0.06°	1.047 mrad
Roll	0.03°	0.523 mrad
Yaw	0.03°	0.523 mrad
Linear Motion Per Motor Rev	54 mm	2.126"
Motor Steps Per Rev	200	
Motor Type	Stepper (2 phase)	
Motor Rated Current	2300 mA/phase	
Motor Winding Resistance	1 ohms/phase	
Inductance	2.2 mH/phase	
Motor Connection	D-sub 15	

Specification	Value	Alternate Unit
Default Resolution	1/64 of a step	
Mechanical Drive System	Synchronous belt	
Limit or Home Sensing	Magnetic home sensor	
Axes of Motion	1	
Mounting Interface	M6 threaded holes and 8-32 threaded holes	
Stage Parallelism	< 100 μ m	< 0.003937"
Operating Temperature Range	0 to 50 °C	
RoHS Compliant	Yes	
CE Compliant	Yes	
Vacuum Compatible	No	
Weight	1.70 kg	3.748 lb

BLQ-E Series Charts

Thrust Speed Performance

with X-MCCx 48V

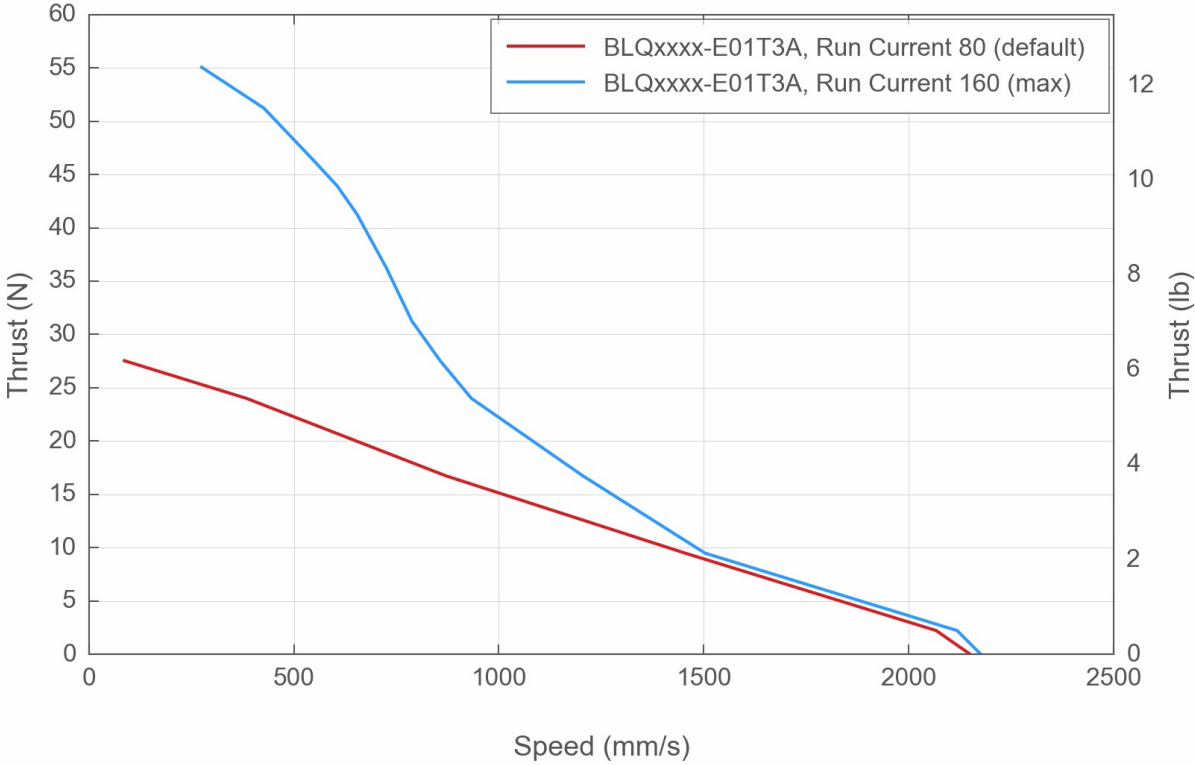

Horizontal Acceleration

with X-MCCx 48V

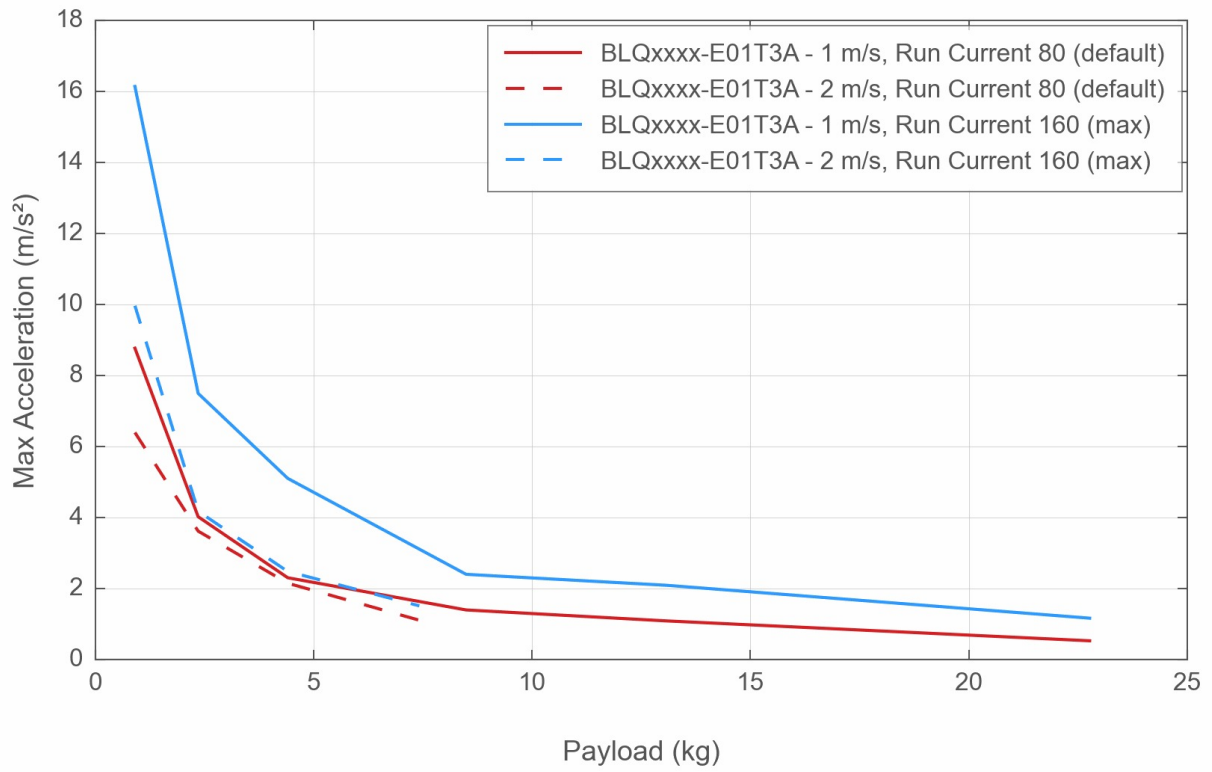

Typical Accuracy

with X-MCCx 48V

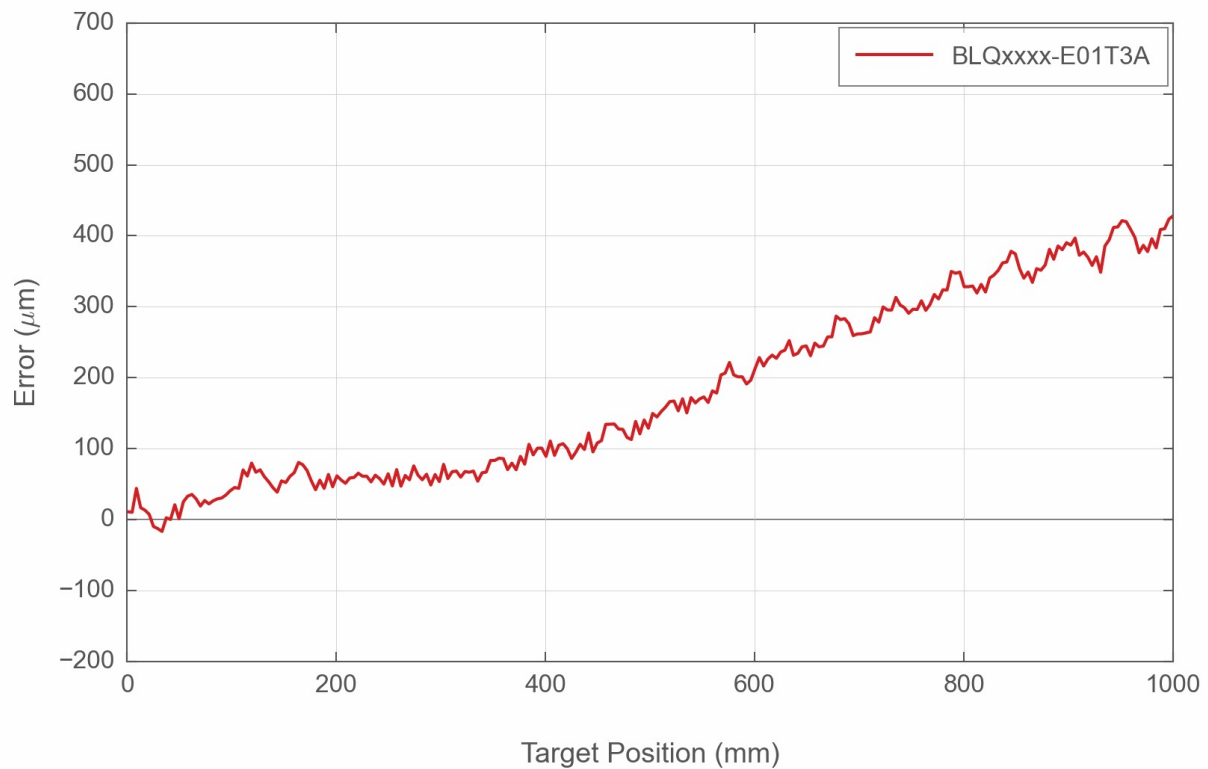

Contact

Email: contact@zaber.com

Phone (toll free Canada/USA): 1-888-276-8033

Phone (direct): 1-604-569-3780

Fax: 1-604-648-8033

Zaber Technologies Inc.

#2 - 605 West Kent Ave. N.

Vancouver, British Columbia

Canada, V6P 6T7

<https://www.zaber.com>