

ZABER

LRUH25-BE01T12A Motorized Stage
 dimensions in mm

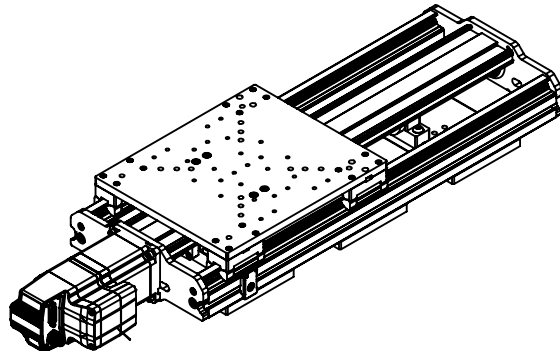

Model Number*	Travel	A	B	C	nxCM
LRU0250H25-BE01T12A	250.0	867.6	650.0	84.8	3
LRU0500H25-BE01T12A	500.0	1117.6	950.0	110.8	4
LRU1000H25-BE01T12A	1000.0	1617.6	1400.0	166.4	5
LRU1500H25-BE01T12A	1500.0	2117.6	1900.0	151.9	7
LRU2000H25-BE01T12A	2000.0	2617.6	2400.0	144.7	9

16X M8X1.25 ∇ 11.5
 93, 120, and 150 mm square
 spacing for cobot mounting
 200 mm X 225 mm spacing
 for RST240 mounting

28X M6X1.0 ∇ 11.5
 25 mm X 100 mm spacing for BLQ, LRQ, LSQ mounting
 50 mm square for RSB60, RSW60, VSR mounting
 75 mm X 150 mm spacing for LDQ, LRT mounting
 100 mm X 125 mm spacing for RST120 mounting

