

LDM-AE Series User's Manual

Ultra precision linear motor stages with built-in linear encoders



Disclaimer

Zaber's products are not intended for use in any critical medical, aviation, or military applications or situations where a product's use or failure could cause personal injury, death, or damage to property. Zaber disclaims any warranty of fitness for a particular purpose. The user of this product agrees to [Zaber's general terms and conditions of sale](#).

Precautions

Zaber's autodetect peripheral axes are designed to be used effortlessly with Zaber's line of autodetect controllers. The LDM-AE includes onboard memory that allows Zaber's controllers to autodetect the model and set reasonable parameters. See the [Protocol Manual](#) for more information on how to modify the settings. Damage to the axis may result if the settings are not correct. To use your Zaber peripheral with a third-party controller, review the motor, sensor, and encoder specifications and pin-outs carefully.

Contamination could impact the performance of the LDM-AE stage. Avoid introduction of ferro-magnetic particles to the stage, and contact with, or contamination of, the encoder scale.

⚠ Mounting and Maintenance Hazard! For operator safety, the LDM-AE should always be un-powered during all cleaning, maintenance, and stage or load mounting operations. A powered stage could exert high forces and move at high speeds very suddenly if accidentally given a move command.

Shipping Safety

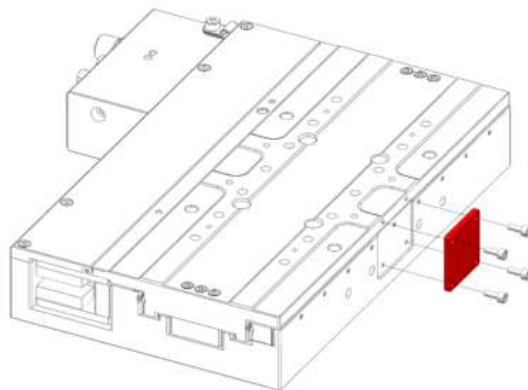

Upon receipt of the stage, remove the shipping security hardware before attempting to power-up the stage. Once removed, retain the security hardware for future use.

If transporting or shipping the stage, the shipping security hardware should be re-installed as shown to ensure the stage does not sustain damage.

Important Precautions for Use

⚠⚠ Strong Magnets! The LDM-AE stages contain strong magnets that could affect pacemaker function. Pacemaker users should stay at least 20 cm away from the stages. The magnets can also attract nearby magnetic objects.

⚠ Secure Stage Mounting Required! The LDM-AE stages can shake and vibrate during operation due to high inertia. The stages must always be securely mounted to a work surface during operation. See [#Physical Installation](#) for information on stage mounting.

⚠ **Back-driving Hazard!** Linear motor stages require current to the motor coils to provide a force to maintain position and/or support a load. If power is removed the carriage may move suddenly or in an uncontrolled manner. The LDM-AE stage is not intended for load lifting operations due to the risk of uncontrolled motion if driver power is removed.

⚠ **Collision Hazard!** Provide a safe distance around the stage and its load to allow for unobstructed full travel movements between travel end-stop bumpers. Ensure that a positional overshoot or unexpected motion couldn't result in a collision hazard.

💡 **Important:** The LDM-AE stage should be homed immediately upon power-up. Behavior may appear jerky during homing. Once the stage has been homed, motion will be controlled and smooth.

💡 **Important:** The LDM-AE is a servo device, meaning that its performance is dependent on proper tuning of the servo parameters for the given load. The use of incorrect servo parameters may reduce the device's performance in operation. Incorrect tuning may also result in unstable operation, which can cause unexpected rapid motion of the device, leading to reduced device lifetime and user injury. When the operating load on the device is changed, the tuning parameters should be updated to match. For details see the servo tuning guidelines.

Lubrication and Cleaning

Many factors affect the lifetime of the grease and bearings including duty cycle, environment, travel length, stage orientation, and loading configuration. As a general guideline for usage in a clean office environment, the recommended re-lubrication interval is 250 km with an inspection after every 1500 hours of continuous operation. Inspection should be done by wiping a bearing rail with a clean, lint-free wipe and ensuring that there is clean, wetted grease present.

Harsh environment, short travel, vertically oriented, and high duty cycle applications require more frequent re-lubrication and inspection. Contact an Applications Engineer to discuss your application for more specific recommendations.

Short travel can cause an insufficient distribution of lubricant amongst the rolling elements of the bearing system. For recirculating bearing guide types, short travel is equal to or less than the length of the carriage. For crossed-roller bearing guide types, short travel is equal to or less than twice the spacing of the rolling elements (typically 5-6 mm). If your application is considered short travel, it is recommended to occasionally drive the stage throughout its full travel range to maintain an even lubrication film over the entire guide surface. More frequent re-lubrication and inspection may be required in these applications.

For longest lubrication intervals, we recommend lubricating guides with Kluberplex BEM 34-132 grease. All guides come pre-lubricated and are ready to go out of the box.

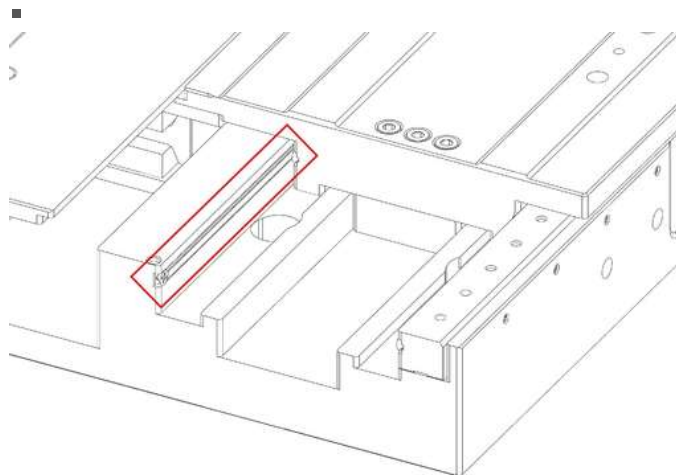

1. **Remove power** to the device before attempting to lubricate.
2. Manually move the stage to a travel limit to expose the linear guides.
3. Using a lint free cloth, wipe away any old grease and debris on the v-channels of the guides. Wipe towards the outside of the stage so debris is not pushed into the roller bearings.
4. Apply a thin strip of lubricant over the entire exposed length of the v-channels with a syringe.
5. Manually move the stage to the opposite travel limit and repeat steps 3 and 4 on the opposite side.
6. Manually move the stage throughout its full travel range a few times to evenly distribute the lubricant.

Noise Emissions

The A-weighted emission sound pressure level (SPL) of this device does not exceed 70 dB(A) during intended use.

Conventions used throughout this document

- Fixed width type indicates communication to and from a device. The μ symbol indicates a carriage return, which can be achieved by pressing enter when using a terminal program.

Device Overview

AutoDetect

Your LDM-AE peripheral is equipped with AutoDetect, a feature that allows a Zaber controller to automatically configure its settings for the peripheral when it is connected.

⚠ Important: The controller should always be powered down before disconnecting or connecting your LDM-AE peripheral.

To connect the peripheral to a controller:

- Power off the controller.
- Connect the LDM-AE peripheral.
- Power on the controller.
- The controller will activate the peripheral shortly after it is powered on.

See the Zaber controller user manual for more details on peripheral activation and control.

Connectors

Recommended controller(s) for your LDM-AE peripheral are provided in the product specifications. Zaber's controllers and peripherals are designed for ease of use when used together. Optimal settings for each peripheral are automatically detected by Zaber's controllers when the device is connected.

For reference, the pinout for the peripheral cable connectors is shown below:

Pinout for D-sub 26 Connectors (peripherals)

Pin	Description	Pin	Description
1	AutoDetect Clock	14	Motor Hall C
2	AutoDetect Data	15	+5V
3	N.C.	16	Ground
4	N.C.	17	N.C.
5	N.C.	18	Motor W
6	Motor Over-Temperature	19	Differential Encoder Sin-
7	Ground	20	Differential Encoder Cos-
8	Motor V	21	Differential Encoder Index-
9	Motor U	22	Motor Hall A
10	Differential Encoder Sin+	23	Motor Hall B
11	Differential Encoder Cos+	24	N.C.
12	Differential Encoder Index+	25	N.C.
13	Differential Encoder Error	26	N.C.

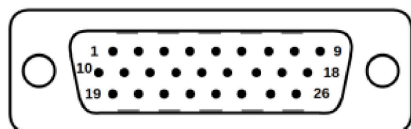

Male High Density D-sub26 Connector
Motor and Sensor Interface

NOTE: All hall sensor signals (for limits or motor phase) are open collector and require a pull-up on the controller.

NOTE: All single-ended encoder inputs are non-isolated 5V TTL lines.

NOTE: All differential encoder signals are non-isolated, and must be terminated on the controller with 120 Ω . For -AE peripherals, these signals are sinusoidal with 1 V peak-to-peak differential levels and with the common mode between 1.5 V and 2.5 V.

Alternate Controllers

The LDM-AE can be controlled by other linear motor controllers with appropriate encoder input. **We do not recommend using your own controller unless you are familiar with wiring and tuning third-party linear motor products.** Damage to the device due to incorrect wiring is not covered by warranty.

Motors & Encoders

For motor and encoder information see the [LDM-AE product page](#)

Installation

The LDM-AE can be operated by connecting to the controller/s recommended in the product specifications. Please review the controller's user manual as well.

Physical Installation

Tip: To obtain the best pitch, roll, yaw and runout performance, mount the stage to a known flat, stiff surface. Our tests were performed on a granite surface plate, grade A flatness.

Stability Hazard! Ensure the stage is fastened to a secure surface before mounting a load on the carriage. Ensure loads are mounted securely to the carriage of the stage before operating.

Mounting and Maintenance Hazard! For operator safety, the LDM-AE should always be un-powered during all cleaning, maintenance, and stage or load mounting operations. A powered stage could exert high forces and move at high speeds very suddenly if accidentally given a move command.

LDM-AE stages are designed to be secured using 4 metric or imperial socket cap screws. The following screw sizes should be used:

- Metric: M6 screws, 25mm or longer
- Imperial: 1/4 screws, 1" or longer

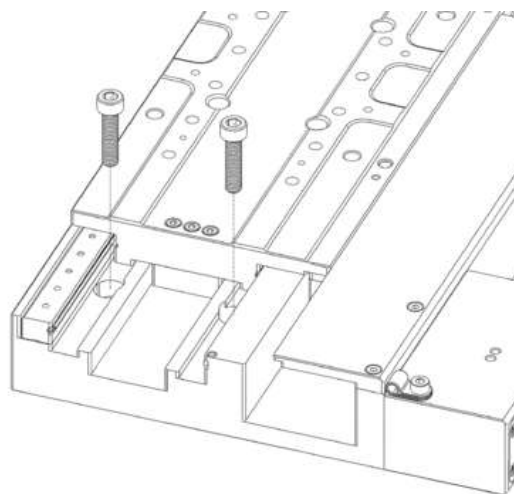

Manually move the stage to its travel limits to access the mounting holes.

XY Assemblies

Pinch Hazard! LDM-AE stages can create pinch hazards between the upper-axis and lower-axis stages when mounted in an XY configuration. Make sure to keep hands clear when powering up the stages.

LDM-AE stages can be mounted directly in XY configurations. LDM-AE stages feature precision machined reference features to allow for optimal orthogonality between two stages in an XY configuration.

-
-

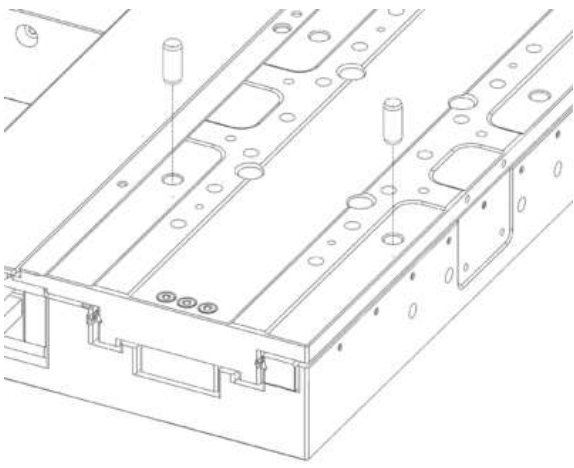

1. Insert two 6mm diameter dowel pins in the holes shown.

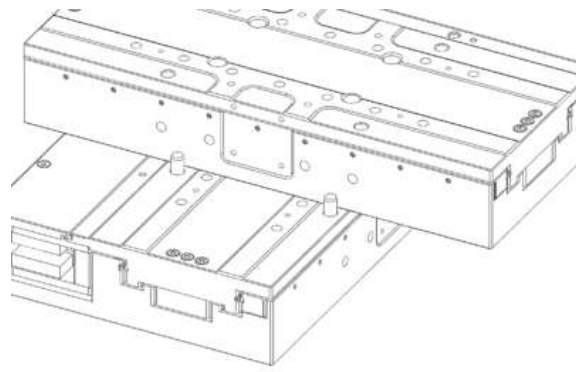

2. Align the edge of the upper-axis stage with the dowel pins.

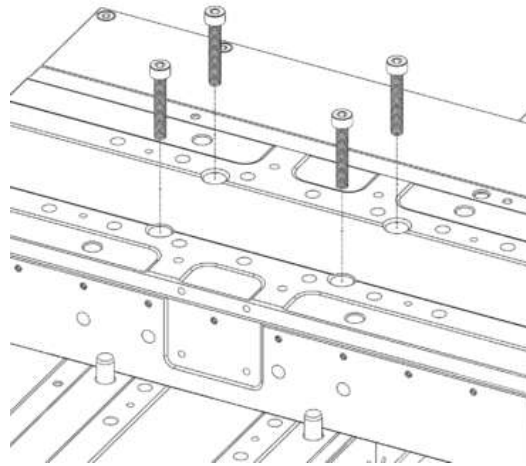

3. Secure the upper-axis stage using 4 M4 x 25mm socket cap screws. **Warning!** Inserting screws that are too long can damage the lower-axis stage.

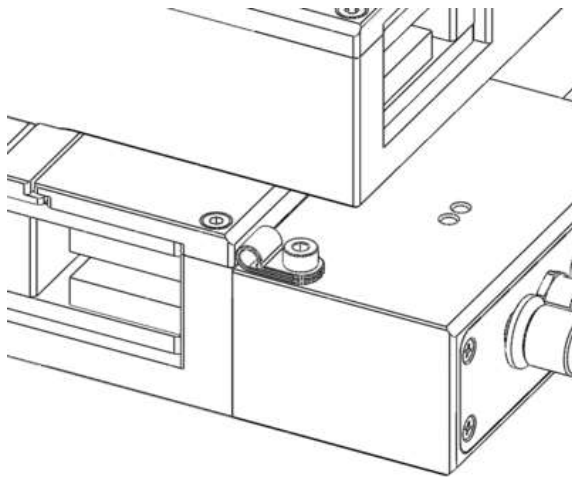

4. The upper-axis daisy-chain cable can be secured using the cable clamp on the lower-axis stage. **Warning!** Leave enough slack in the cable so the lower-axis stage can move unrestricted throughout its full travel range.

Servo Tuning

This peripheral is a closed-loop positioning servo system. It continuously monitors and corrects its position via the linear encoder. As with any servo system, the behaviour is dependent on the controller tuning. The LDM-AE, when paired with a compatible Zaber controller, such as an X-MCC series Universal Motor Controller, will be appropriately tuned out of the box with settings that are optimized for regular use under a light load. However, as with any closed-loop feedback system, the device performance is load-dependent, and conditions significantly outside of the

intended operating range have the potential for reduced performance or instability. Thus, if operation with large or unconventional dynamic loads is desired, or if the application demands specific performance characteristics, it may be necessary to tune the servo parameters. This may be conveniently done by using Zaber Launcher's Servo Tuner App, or [Zaber Motion Library's](#) ServoTuner API.

 **Tip:** Because servo devices continuously monitor and correct position, it is necessary to specify how accurate and stable the final position must be at the end of the movement. Criteria required for the controller to report IDLE status after movement are specified using the [cloop.settle.tolerance](#) and [cloop.settle.period](#) settings. For applications requiring utmost precision, you may want to specify a smaller tolerance and longer period. Note that there is a direct, inverse relationship between settling time and [cloop.settle.tolerance](#), and the controller may never report IDLE status if the tolerance is too small.

Trajectory Control and Behaviour

This section describes the behaviour of the axis trajectory when a movement command is issued.

Software Position Limits

The travel range of the axis is limited by the Minimum Position and Maximum Position settings. The factory settings for the axis are configured to match the physical travel range. If a customized range is desired, it can be changed by configuring the [limit.min](#) and [limit.max](#) settings to appropriate values. For the Current Position, query [pos](#).

Minimum Position

When the Current Position is less than the Minimum Position value, the axis cannot move in the negative direction.

Maximum Position

When the Current Position is greater than the Maximum Position value, the axis cannot move in the positive direction.

Movement Speed

The movement speed of the axis depends on axis status and various speed settings. If the axis has not been initialized by the [home](#) command or by moving towards the home end of the axis, movement speed will be constrained to fail-safe values. The home status of the axis can be determined by reading the [limit.home.triggered](#) setting.

Movement speed of the axis is specified below:

[move vel](#)

The axis will move at the specified speed regardless of home status.

Knob movement in Velocity Mode

The axis will move at the specified speed regardless of home status.

The speed is specified by the [knob.speedprofile](#) and [knob.maxspeed](#) settings.

Other movement commands - when the axis has not been homed

The axis will move at the slower of the [maxspeed](#) and [limit.approach.maxspeed](#) settings.

Other movement commands - when the axis has been homed

The axis will move at the speed specified by the [maxspeed](#) setting.

Warranty and Repair

For Zaber's policies on warranty and repair, please refer to the [Ordering Policies](#).

Standard products

Standard products are any part numbers that do not contain the suffix ENG followed by a 4 digit number. Most, but not all, standard products are listed for sale on our website. All standard Zaber products are backed by a one-month satisfaction guarantee. If you are not satisfied with your purchase, we will refund your payment minus any shipping charges. Goods must be in brand new saleable condition with no marks. Zaber products are guaranteed for one year. During this period Zaber will repair any products with faults due to manufacturing defects, free of charge.

Custom products

Custom products are any part numbers containing the suffix ENG followed by a 4 digit number. Each of these products has been designed for a custom application for a particular customer. Custom products are guaranteed for one year, unless explicitly stated otherwise. During this period Zaber will repair any products with faults due to manufacturing defects, free of charge.

How to return products

Customers with devices in need of return or repair should contact Zaber to obtain an RMA form which must be filled out and sent back to us to receive an RMA number. The RMA form contains instructions for packing and returning the device. The specified RMA number must be included on the shipment to ensure timely processing.

Email Updates

If you would like to receive our periodic email newsletter including product updates and promotions.

Contact Information

Contact Zaber Technologies Inc by any of the following methods:

Phone	1-604-569-3780 (direct) 1-888-276-8033 (toll free in North America)
Fax	1-604-648-8033
Mail	#2 - 605 West Kent Ave. N., Vancouver, British Columbia, Canada, V6P 6T7
Web	www.zaber.com
Email	Please visit our website for up to date email contact information.

The original instructions for this product are available at <https://www.zaber.com/manuals/LDM-AE>.

Appendix A: Default Settings

Please see [the Zaber Support Page](#) for default settings for this device.

Product Drawing

ZABER

LDM-AE Direct Drive Linear Stage
dimensions in mm

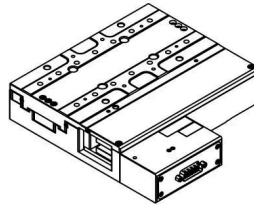

Model Number*	Nominal Travel	Hard Stop Travel	A	B
LDM060C-AE54T10A	60.0	76.0	190.0	125.0 or 127.0 [5"]
LDM110C-AE54T10A	110.0	126.0	245.0	150.0 or 152.4 [6"]
LDM210C-AE54T10A	210.0	226.0	345.0	175.0 or 177.8 [7"]

*See product page for complete list of available models at www.zaber.com

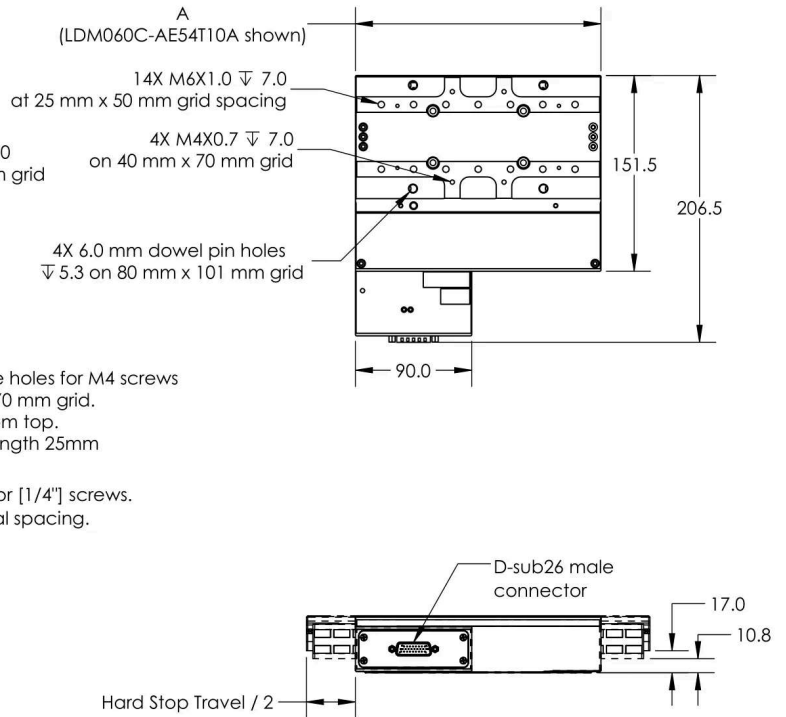
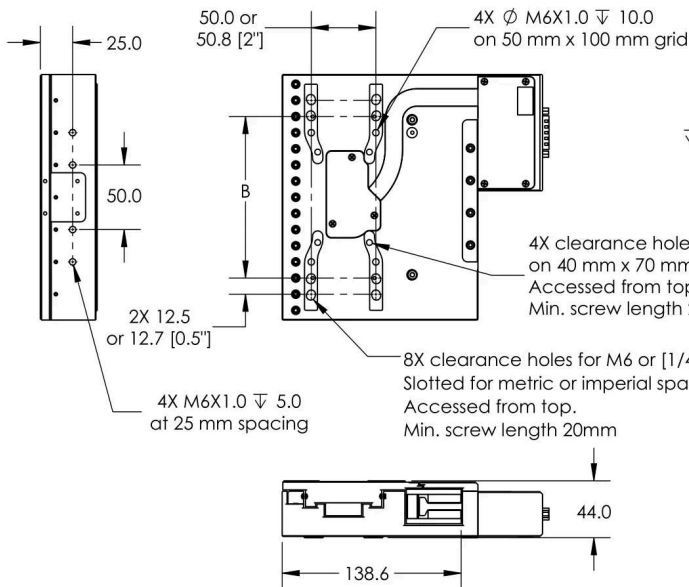

DWG 3076 R01B

Specifications

Specification	Value	Alternate Unit
Built-in Controller	No	
Recommended Controller	X-MCC (48 V) Recommended	

Specification	Value	Alternate Unit
AutoDetect	Yes	
Accuracy (unidirectional)	1 μm	0.000039"
Repeatability	< 0.08 μm	< 0.000003"
Minimum Incremental Move	4 nm	
Maximum Speed	1200 mm/s	47.244"/s
Minimum Speed	0.61 nm/s	
Speed Resolution	0.61 nm/s	
Encoder Type	Linear analog encoder	
Encoder Count Size	1 nm	
Peak Thrust	100 N	22.4 lb
Maximum Continuous Thrust	35 N	7.8 lb
Maximum Centered Load	185 N	41.5 lb
Maximum Moment (Pitch)	1200 N·cm	1699.3 oz·in
Maximum Moment (Roll)	1200 N·cm	1699.3 oz·in
Maximum Moment (Yaw)	1200 N·cm	1699.3 oz·in
Typical Velocity Stability	$\pm 0.11\%$ at 100 mm/s with a 1.0 kg payload	
Motor Type	Moving Magnet Track Linear Motor	
Motor Rated Current	2400 mA/phase	
Force Constant	15.8 N/A	3.5 lbs/A
Motor Winding Resistance	6.4 ohms/phase	
Inductance	1.24 mH/phase	
Guide Type	Crossed-Roller Bearing	
Axes of Motion	1	
Mounting Interface	M6 threaded holes	
Operating Temperature Range	0 to 50 °C	
CE Compliant	Yes	
Vacuum Compatible	No	

Comparison

Part Number	Travel Range	Maximum Acceleration	Vertical Runout	Horizontal Runout
LDM060C-AE54T10A	60 mm (2.362")	34.3 m/s ² (3.50 g)	< 4 μm (< 0.000157")	< 3 μm (< 0.000118")
LDM110C-AE54T10A	110 mm (4.331")	24.5 m/s ² (2.50 g)	< 4 μm (< 0.000157")	< 3 μm (< 0.000118")
LDM210C-AE54T10A	210 mm (8.268")	14.7 m/s ² (1.50 g)	< 8 μm (< 0.000315")	< 5 μm (< 0.000197")

Part Number	Pitch	Roll	Yaw	Moving Mass
LDM060C-AE54T10A	0.003° (0.052 mrad)	0.002° (0.035 mrad)	0.002° (0.035 mrad)	1.74 kg (3.828 lbs)
LDM110C-AE54T10A	0.005° (0.087 mrad)	0.005° (0.087 mrad)	0.002° (0.035 mrad)	2.29 kg (5.038 lbs)
LDM210C-AE54T10A	0.01° (0.174 mrad)	0.005° (0.087 mrad)	0.005° (0.087 mrad)	3.17 kg (6.974 lbs)

Part Number	Weight
LDM060C-AE54T10A	3.73 kg (8.223 lb)
LDM110C-AE54T10A	4.81 kg (10.604 lb)
LDM210C-AE54T10A	6.57 kg (14.484 lb)

Typical Accuracy

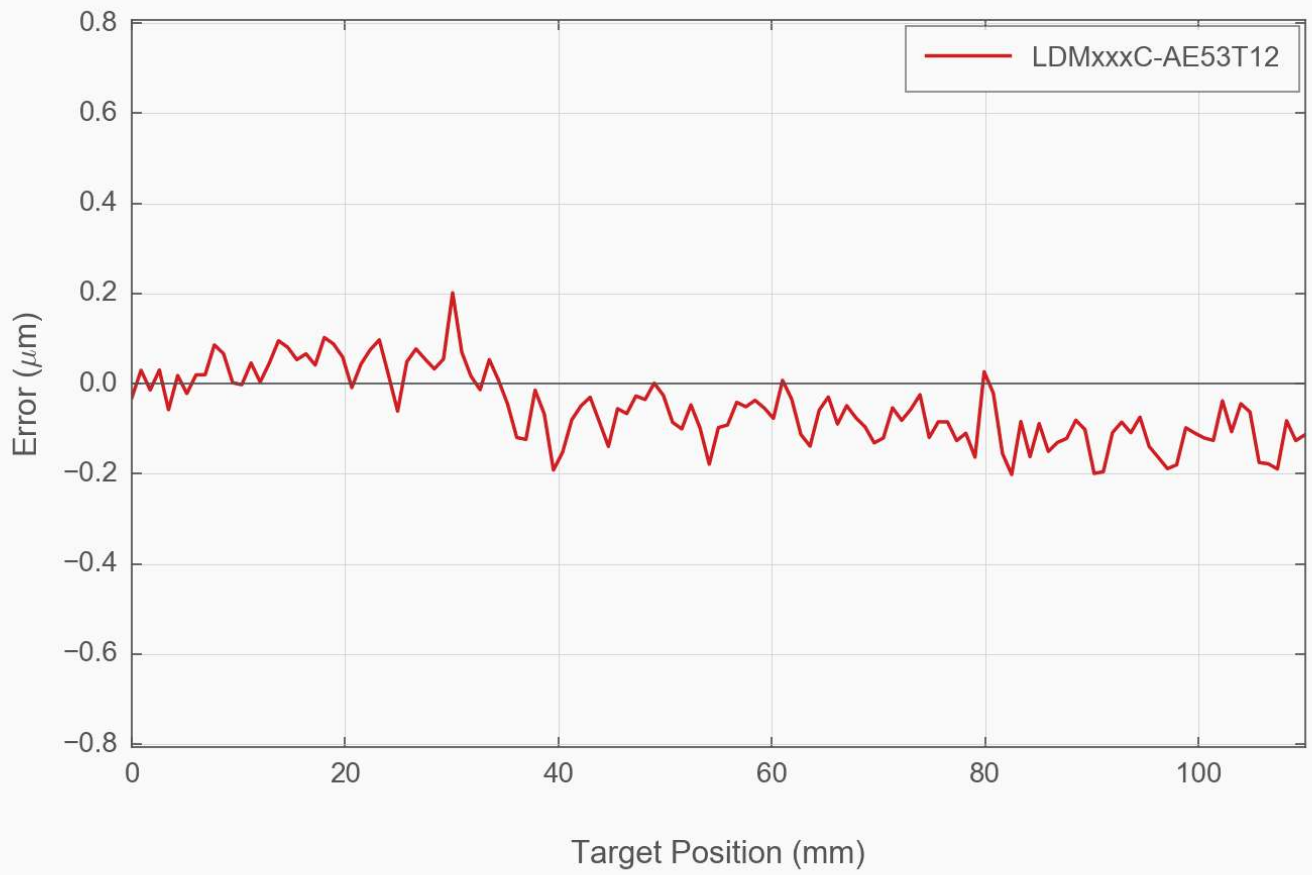

Typical Minimum Incremental Move

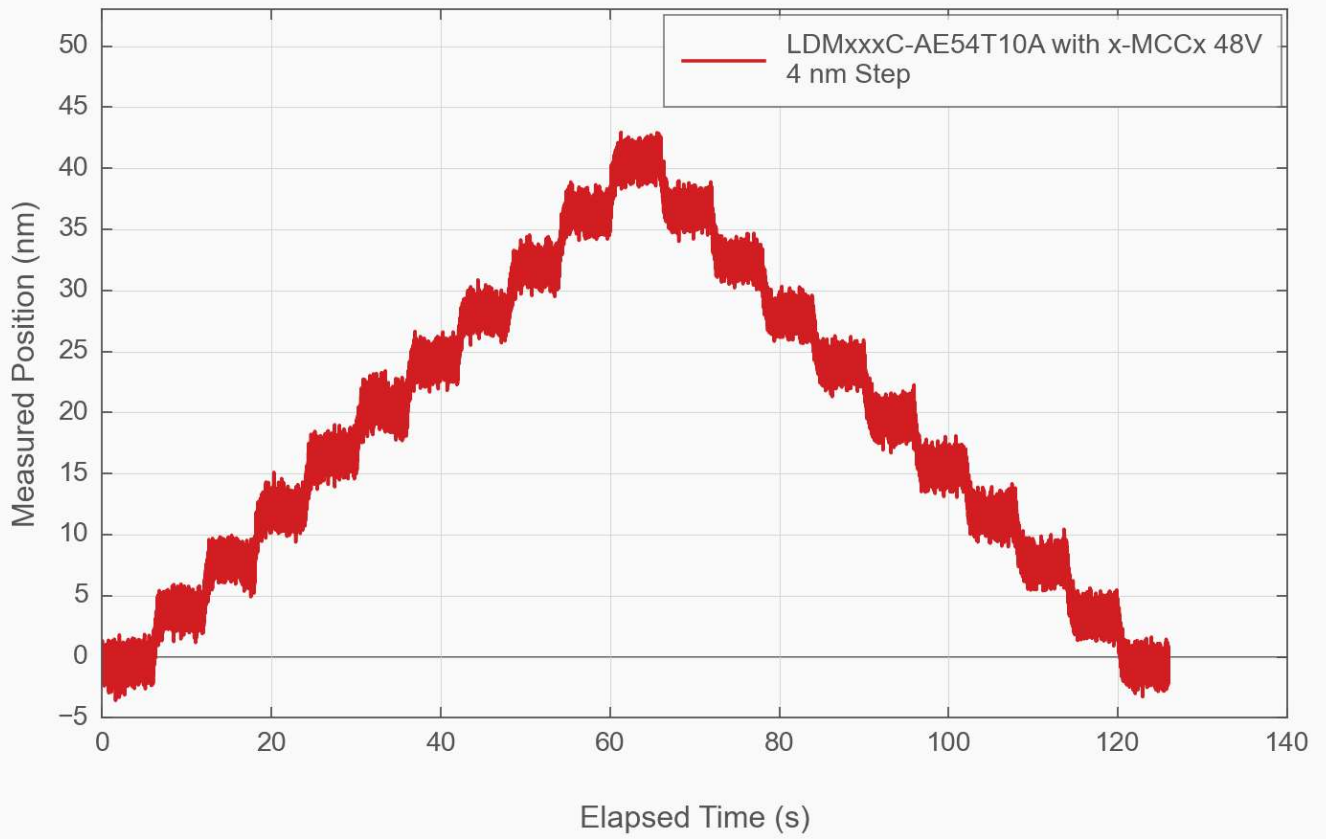

Typical Velocity Stability and Following Error

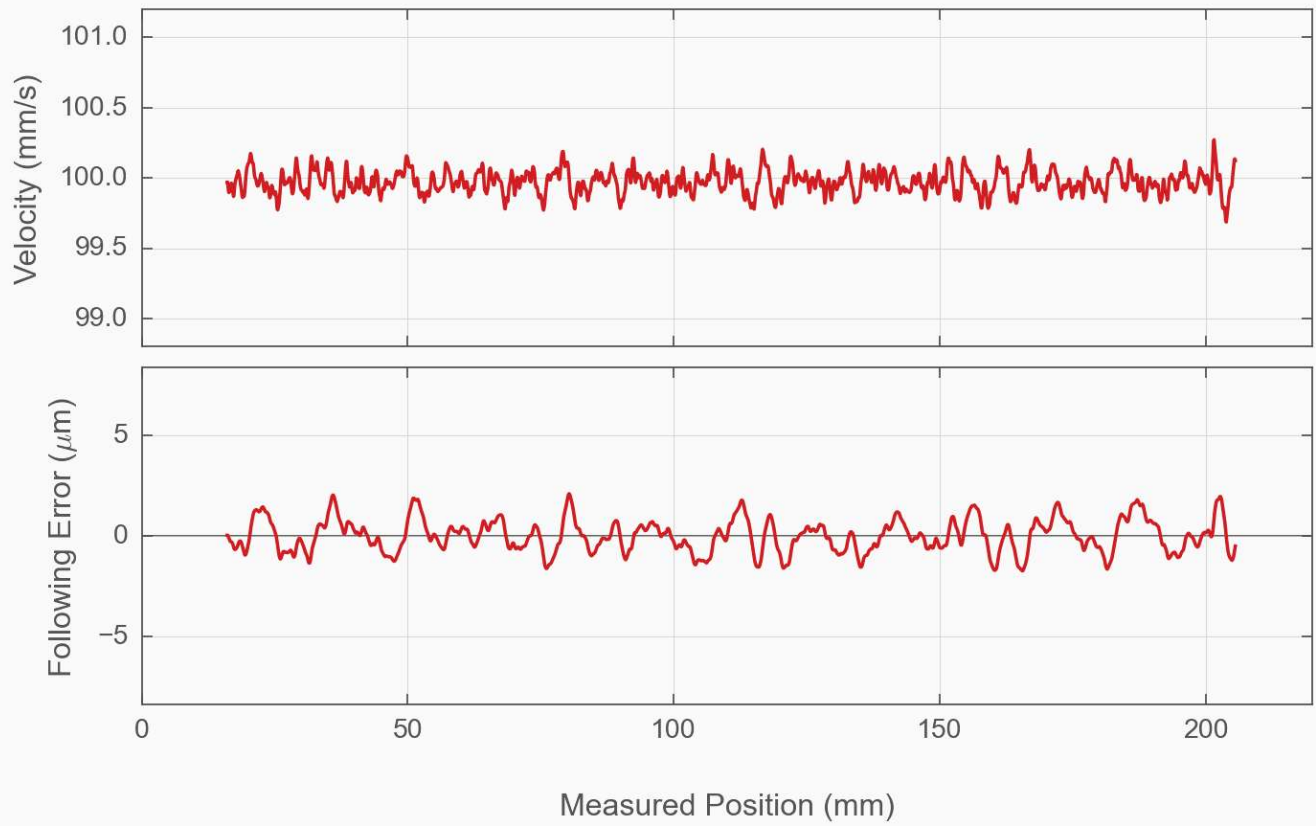

Product Change Notices

Click [here](#) to view the current product change notices and subscribe to future change notifications.