

LRQ-E Series User's Manual

Motorized linear stages with built-in motor encoders



Disclaimer

Zaber's products are not intended for use in any critical medical, aviation, or military applications or situations where a product's use or failure could cause personal injury, death, or damage to property. Zaber disclaims any warranty of fitness for a particular purpose. The user of this product agrees to [Zaber's general terms and conditions of sale](#).

Precautions

Zaber's autodetect peripheral axes are designed to be used effortlessly with Zaber's line of autodetect controllers. The LRQ-E includes onboard memory that allows Zaber's controllers to autodetect the model and set reasonable parameters. See the [Protocol Manual](#) for more information on how to modify the settings. Damage to the axis may result if the settings are not correct. To use your Zaber peripheral with a third-party controller, review the motor, sensor, and encoder specifications and pin-outs carefully.

Zaber's motion control devices are precision instruments and must be handled with care. In particular, moving parts must be treated with care. Avoid axial loads in excess of the rated thrust load, axial and radial impact, dust and other contaminants and damage to the lead screw thread. These will reduce the performance of the device below stated specifications.

Lubrication of linear guides

Many factors affect the lifetime of the grease and bearings including duty cycle, environment, travel length, stage orientation, and loading configuration. As a general guideline for usage in a clean office environment, the recommended re-lubrication interval is 250 km with an inspection after every 1500 hours of continuous operation. Inspection should be done by wiping a bearing rail with a clean, lint-free wipe and ensuring that there is clean, wetted grease present.

Harsh environment, short travel, vertically oriented, and high duty cycle applications require more frequent re-lubrication and inspection. Contact an Applications Engineer to discuss your application for more specific recommendations.

Short travel can cause an insufficient distribution of lubricant amongst the rolling elements of the bearing system. For recirculating bearing guide types, short travel is equal to or less than the length of the carriage. For crossed-roller bearing guide types, short travel is equal to or less than twice the spacing of the rolling elements (typically 5-6 mm). If your application is considered short travel, it is recommended to occasionally drive the stage throughout its full travel range to maintain an even lubrication film over the entire guide surface. More frequent re-lubrication and inspection may be required in these applications.

Contact [Zaber support](#) for [relubrication kit SG133](#). We recommend using Shell Gadus S2 V220 2 or similar lithium thickened petroleum grease. We recommend using 0.2 cm³ per bearing block of grease. The grease ports are located on the motor end of the carriage (see pictures below). Simply remove the screw plugs using a 2.5 mm hex key and inject about 0.2 cm³ of grease into each port. Cycle the stage through its travel several times and wipe off any excess grease from the rails. All guides come pre-lubricated and are ready to go out of the box.



Re-lubricating LRQ linear guide

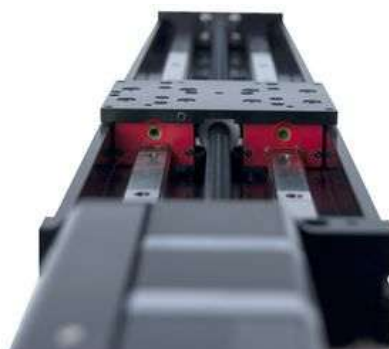

Ball Screw Relubrication

This is applicable for devices equipped with a ball screw. Like the linear bearings, many factors affect the lifetime of the grease and ball screw. We recommend an inspection of the ball screw surface every 200 hours of continuous operation and a relubrication at least every 500 hours with Shell Gadus S2 V220 2, available in the [relubrication kit SG133](#).

Lead screw noise

If your lead screw equipped stage develops a chirping or squealing sound while moving, especially at high speed, lubricating the lead screw will usually solve the problem. We recommend Super Lube 52004 Synthetic Lightweight Oil.

- Move the carriage to the away position.
- Wipe the lead screw clean of any dust or debris before application.
- Apply a small line (≈ 1 mm wide) of Super Lube down the whole length of the lead screw. Be careful not to get any oil into the lead nut as it can interfere with the anti-backlash mechanism.
- Move the carriage slowly (speed $\sim 20,000$ Zaber units) to the home position to evenly distribute the oil.



Applying Super Lube to the lead screw



This is a good amount of oil. Do not over lubricate, it should not be dripping off the screw. Wipe off any excess with a clean, lint-free wipe.

Conventions used throughout this document

- Fixed width type indicates communication to and from a device. The ↵ symbol indicates a carriage return, which can be achieved by pressing enter when using a terminal program.
- An [ASCII command](#) followed by (T:xx) indicates a legacy T-Series [Binary Protocol](#) command that achieves the same result. For example, `move abs 10000 (T:20:10000)` shows that a move abs ASCII command can also be achieved with Binary command number 20.

Not all ASCII commands have an equivalent Binary counterpart.

Device Overview

AutoDetect

Your LRQ-E peripheral is equipped with AutoDetect, a feature that allows a Zaber controller to automatically configure its settings for the peripheral when it is connected.

💡 **Important:** The controller should always be powered down before disconnecting or connecting your LRQ-E peripheral.

To connect the peripheral to a controller:

- Power off the controller.
- Connect the LRQ-E peripheral.
- Power on the controller.
- The controller will activate the peripheral shortly after it is powered on.

See the Zaber controller user manual for more details on peripheral activation and control.

Connectors

Recommended controller(s) for your LRQ-E peripheral are provided in the product specifications. Zaber's controllers and peripherals are designed for ease of use when used together. Optimal settings for each peripheral are automatically detected by Zaber's controllers when the device is connected.

For reference, the pinout for the peripheral cable connectors is shown below:

Pinout for D-sub 15 Connectors (peripherals)

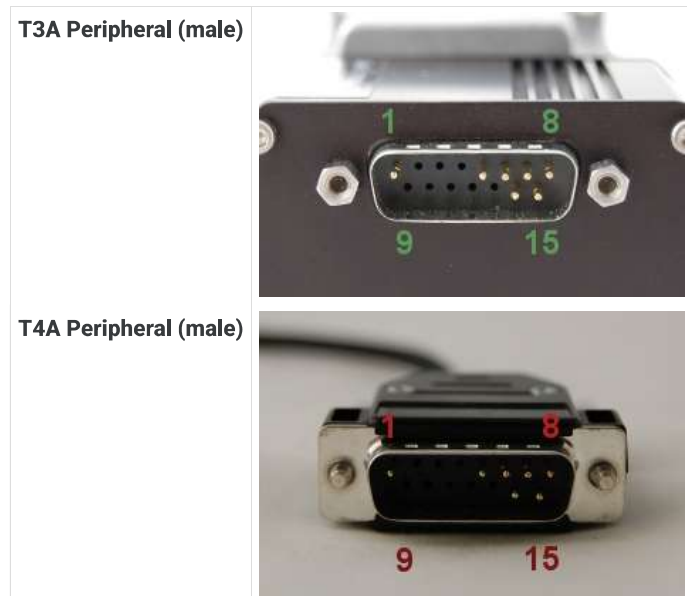

Pin #	Function
1	+5V for Limits & Encoder
2	AutoDetect Data
3	<i>reserved</i>
4	Away Sensor
5	Home Sensor
6	Ground
7	Motor B1
8	Motor A1
9	AutoDetect Clock
10	Encoder A
11	Encoder B
12	Encoder Index
13	Ground
14	Motor B2
15	Motor A2

Not all pins are used for all models

Alternate Controllers

The LRQ-E can be controlled by any 2-phase stepper motor controller with limit sensor and appropriate encoder input. **We do not recommend using your own controller unless you are familiar with how to control a stepper motor with encoders and hall sensor limit switches.** Damage to the device due to incorrect wiring is not covered by warranty.

Motors & Encoders

For motor and encoder information see the [LRQ-E product page](#)

Limit Sensors

Hall effect sensors are used in the LRQ-E as home sensors. The Hall sensors used are part number A1120LLHLT-T made by Allegro. [Click here for data sheet](#). Your controller should be configured so the stage stops immediately (quick deceleration) when the sensors are triggered.

- PCB wire colour code:
 - 5 Vdc input - red
 - Home signal - yellow
 - Away signal - white
 - Ground - black

The Hall sensor has an open-collector output. The default output is high impedance when the Hall sensor is not active. When the sensor detects a magnet, the Hall sensor pulls the output low to ground.

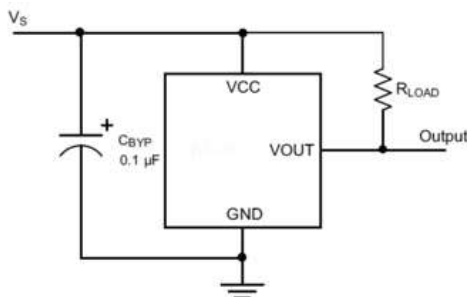

If you are not using a Zaber controller, ensure that your controller has a pull-up resistor on the output line of each Hall sensor as shown in the diagram. The bypass capacitor is optional, but may help to eliminate false triggering in noisy environments. The typical value for the pull-up resistor (R_{LOAD}) is 10 k Ω and for the bypass capacitor is 0.1 μ F to 1 μ F. The larger the capacitance, the better the noise filtering but the slower the response time.

Installation

Physical Installation

The LRQ-E stage has two sets of mounting features that are acceptable means of fastening the stage to a structure. The first are the slotted holes in the middle of the stage which use M6 fasteners on a 25 mm x 50 mm grid. The second set of mounting features are the T-slots located on the bottom of the stage which are 84 mm apart. The T-slots will generally accept T-nuts that are used in 20 mm aluminum T-slot extrusions.



■ **Do not mount the stage using the T-slots on the side on the device.** The T-slots are designed for use with accessories such as limit sensors, linear encoders, and cable trays only. This T-slot is designed to accept a standard M2.5 hex nut. Damage will occur if these T-slots are used to mount the stage.

Trajectory Control and Behaviour

This section describes the behaviour of the axis trajectory when a movement command is issued.

Software Position Limits

The travel range of the axis is limited by the Minimum Position and Maximum Position settings. The factory settings for the axis are configured to match the physical travel range. If a customized range is desired, it can be changed by configuring the [limit.min \(T:106\)](#) and [limit.max \(T:44\)](#) settings to appropriate values. For the Current Position, query [pos \(T:60\)](#).

Minimum Position

When the Current Position is less than the Minimum Position value, the axis cannot move in the negative direction (towards the motor).

Maximum Position

When the Current Position is greater than the Maximum Position value, the axis cannot move in the positive direction (away from the motor).

Movement Speed

The movement speed of the axis depends on axis status and various speed settings. If the axis has not been initialized by the [home \(T:1\)](#) command or by moving towards the home end of the axis, movement speed will be constrained to fail-safe values. The home status of the axis can be determined by reading the [limit.home.triggered\(T:53:103\)](#) setting.

Movement speed of the axis is specified below:

[move vel \(T:22\)](#)

The axis will move at the specified speed regardless of home status.

Knob movement in Velocity Mode

The axis will move at the specified speed regardless of home status.

The speed is specified by the [knob.speedprofile \(T:112\)](#) and [knob.maxspeed \(T:111\)](#) settings.

Other movement commands - when the axis has not been homed

The axis will move at the slower of the [maxspeed \(T:42\)](#) and [limit.approach.maxspeed \(T:41\)](#) settings.

Other movement commands - when the axis has been homed

The axis will move at the speed specified by the [maxspeed \(T:42\)](#) setting.

Warranty and Repair

For Zaber's policies on warranty and repair, please refer to the [Ordering Policies](#).

Standard products

Standard products are any part numbers that do not contain the suffix ENG followed by a 4 digit number. Most, but not all, standard products are listed for sale on our website. All standard Zaber products are backed by a one-month satisfaction guarantee. If you are not satisfied with your purchase, we will refund your payment minus any shipping charges. Goods must be in brand new saleable condition with no marks. Zaber products are guaranteed for one year. During this period Zaber will repair any products with faults due to manufacturing defects, free of charge.

Custom products

Custom products are any part numbers containing the suffix ENG followed by a 4 digit number. Each of these products has been designed for a custom application for a particular customer. Custom products are guaranteed for one year, unless explicitly stated otherwise. During this period Zaber will repair any products with faults due to manufacturing defects, free of charge.

How to return products

Customers with devices in need of return or repair should contact Zaber to obtain an RMA form which must be filled out and sent back to us to receive an RMA number. The RMA form contains instructions for packing and returning the device. The specified RMA number must be included on the shipment to ensure timely processing.

Email Updates

If you would like to receive our periodic email newsletter including product updates and promotions.

Contact Information

Contact Zaber Technologies Inc by any of the following methods:

Phone	1-604-569-3780 (direct) 1-888-276-8033 (toll free in North America)
Fax	1-604-648-8033
Mail	#2 - 605 West Kent Ave. N., Vancouver, British Columbia, Canada, V6P 6T7
Web	www.zaber.com
Email	Please visit our website for up to date email contact information.

The original instructions for this product are available at <https://www.zaber.com/manuals/LRQ-E>.

Appendix A: Default Settings

Please see [the Zaber Support Page](#) for default settings for this device.

Product Drawings

ZABER

LRQxL-E Motorized Linear Stage
dimensions in mm

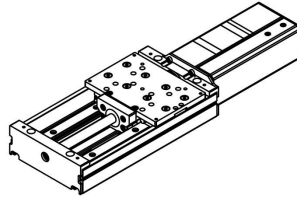

Model Number*	Travel	A	B
LRQ075xL-E	75.0	320.0	167.0
LRQ150xL-E	150.0	395.0	242.0
LRQ300xL-E	300.0	545.0	392.0
LRQ450xL-E	450.0	695.0	542.0
LRQ600xL-E	600.0	845.0	692.0

*See product page for complete list of available models at www.zaber.com

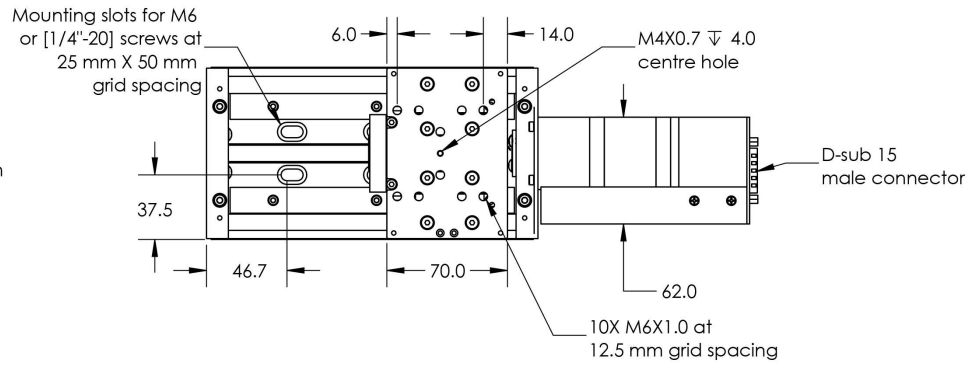

Recommended fastener for side T-slots: standard M2.5 nuts
Note: Do not mount stage using these side T-slots. For accessories only

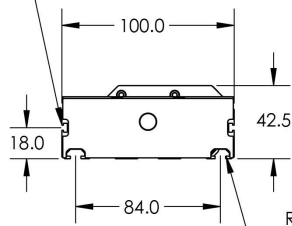

Recommended fastener for bottom T-slots: 6mm T-nuts

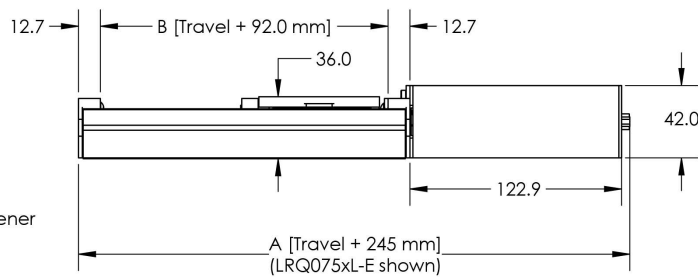

ZABER

LRQxP-E Motorized Linear Stage
dimensions in mm

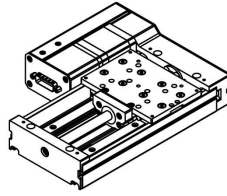

Model Number*	Travel	A	B
LRQ075xP-E	75.0	209.8	167.0
LRQ150xP-E	150.0	284.8	242.0
LRQ300xP-E	300.0	434.8	392.0
LRQ450xP-E	450.0	584.8	542.0
LRQ600xP-E	600.0	734.8	692.0

*See product page for complete list of available models at www.zaber.com

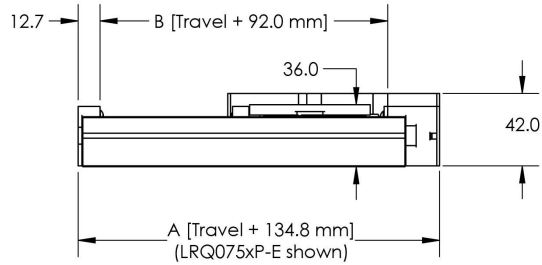
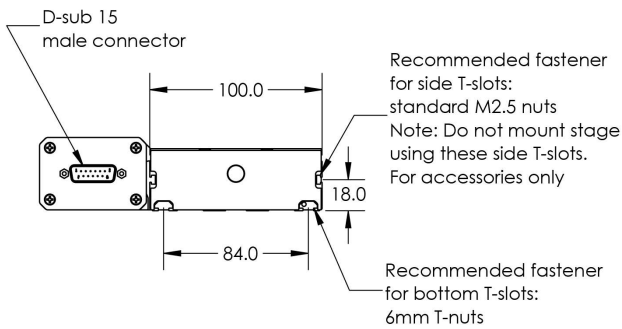
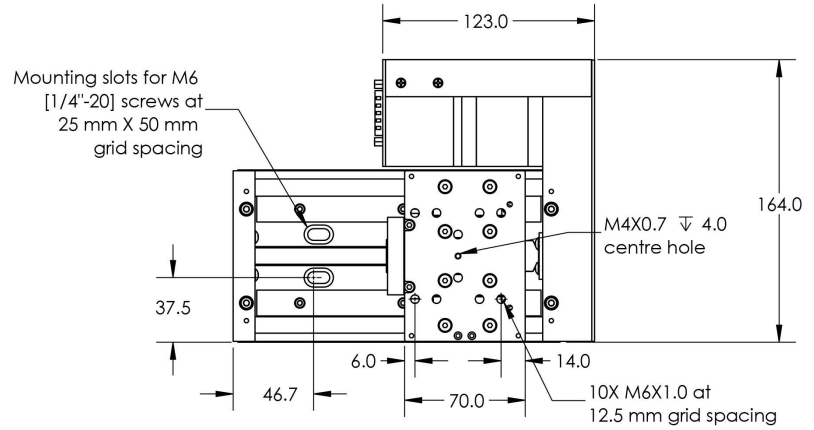

DWG 1259 R01A

Specifications

Specification	Value	Alternate Unit
Built-in Controller	No	
Recommended Controller	X-MCC (48 V) Recommended	
AutoDetect	Yes	
Encoder Resolution	500 CPR	2000 states/rev
Encoder Type	Rotary quadrature encoder	
Maximum Centered Load	1000 N	224.3 lb
Maximum Moment (Pitch)	30 N·m	22.1 ft·lb
Maximum Moment (Roll)	30 N·m	22.1 ft·lb
Maximum Moment (Yaw)	30 N·m	22.1 ft·lb
Stiffness in Pitch	500 N·m/°	35 μrad/N·m
Stiffness in Roll	1180 N·m/°	15 μrad/N·m
Stiffness in Yaw	450 N·m/°	39 μrad/N·m
Motor Steps Per Rev	200	
Motor Type	Stepper (2 phase)	
Motor Rated Current	2300 mA/phase	
Motor Winding Resistance	1 ohms/phase	
Inductance	2.2 mH/phase	
Motor Connection	D-sub 15	

Specification	Value	Alternate Unit
Default Resolution	1/64 of a step	
Guide Type	Recirculating Ball Linear Guide	
Limit or Home Sensing	Magnetic home sensor	
Axes of Motion	1	
Mounting Interface	M6 and M3 threaded holes	
Operating Temperature Range	0 to 50 °C	
CE Compliant	Yes	
Vacuum Compatible	No	

Comparison

Part Number	Microstep Size (Default Resolution)	Travel Range	Accuracy (unidirectional)	Repeatability
LRQ075AL-E01T3A	0.09921875 µm	75 mm (2.953")	23 µm (0.000906")	< 2.5 µm (< 0.000098")
LRQ075BL-E01T3A	0.49609375 µm	75 mm (2.953")	15 µm (0.000591")	< 2.5 µm (< 0.000098")
LRQ075DL-E01T3A	1.984375 µm	75 mm (2.953")	48 µm (0.001890")	< 3 µm (< 0.000118")
LRQ075HL-E01T3A	0.1953125 µm	75 mm (2.953")	17.5 µm (0.000689")	< 5 µm (< 0.000197")
LRQ150AL-E01T3A	0.09921875 µm	150 mm (5.905")	45 µm (0.001772")	< 2.5 µm (< 0.000098")
LRQ150BL-E01T3A	0.49609375 µm	150 mm (5.905")	25 µm (0.000984")	< 2.5 µm (< 0.000098")
LRQ150DL-E01T3A	1.984375 µm	150 mm (5.905")	55 µm (0.002165")	< 3 µm (< 0.000118")
LRQ150HL-E01T3A	0.1953125 µm	150 mm (5.905")	30 µm (0.001181")	< 5 µm (< 0.000197")
LRQ300AL-E01T3A	0.09921875 µm	300 mm (11.811")	90 µm (0.003543")	< 2.5 µm (< 0.000098")
LRQ300BL-E01T3A	0.49609375 µm	300 mm (11.811")	35 µm (0.001378")	< 2.5 µm (< 0.000098")
LRQ300DL-E01T3A	1.984375 µm	300 mm (11.811")	70 µm (0.002756")	< 3 µm (< 0.000118")
LRQ300HL-E01T3A	0.1953125 µm	300 mm (11.811")	55 µm (0.002165")	< 5 µm (< 0.000197")
LRQ450AL-E01T3A	0.09921875 µm	450 mm (17.716")	135 µm (0.005315")	< 2.5 µm (< 0.000098")
LRQ450BL-E01T3A	0.49609375 µm	450 mm (17.716")	60 µm (0.002362")	< 2.5 µm (< 0.000098")
LRQ450DL-E01T3A	1.984375 µm	450 mm (17.716")	85 µm (0.003346")	< 3 µm (< 0.000118")
LRQ450HL-E01T3A	0.1953125 µm	450 mm (17.716")	85 µm (0.003346")	< 5 µm (< 0.000197")
LRQ600AL-E01T3A	0.09921875 µm	600 mm (23.622")	150 µm (0.005905")	< 2.5 µm (< 0.000098")
LRQ600BL-E01T3A	0.49609375 µm	600 mm (23.622")	90 µm (0.003543")	< 2.5 µm (< 0.000098")
LRQ600DL-E01T3A	1.984375 µm	600 mm (23.622")	100 µm (0.003937")	< 3 µm (< 0.000118")
LRQ600HL-E01T3A	0.1953125 µm	600 mm (23.622")	115 µm (0.004528")	< 5 µm (< 0.000197")
LRQ075AP-E01T3A	0.09921875 µm	75 mm (2.953")	23 µm (0.000906")	< 2.5 µm (< 0.000098")
LRQ075BP-E01T3A	0.49609375 µm	75 mm (2.953")	15 µm (0.000591")	< 2.5 µm (< 0.000098")
LRQ075DP-E01T3A	1.984375 µm	75 mm (2.953")	15 µm (0.000591")	< 2.5 µm (< 0.000098")
LRQ075HP-E01T3A	0.1953125 µm	75 mm (2.953")	27.5 µm (0.001083")	< 5 µm (< 0.000197")
LRQ150AP-E01T3A	0.09921875 µm	150 mm (5.905")	45 µm (0.001772")	< 2.5 µm (< 0.000098")
LRQ150BP-E01T3A	0.49609375 µm	150 mm (5.905")	25 µm (0.000984")	< 2.5 µm (< 0.000098")
LRQ150DP-E01T3A	1.984375 µm	150 mm (5.905")	55 µm (0.002165")	< 3 µm (< 0.000118")
LRQ150HP-E01T3A	0.1953125 µm	150 mm (5.905")	40 µm (0.001575")	< 5 µm (< 0.000197")
LRQ300AP-E01T3A	0.09921875 µm	300 mm (11.811")	90 µm (0.003543")	< 2.5 µm (< 0.000098")
LRQ300BP-E01T3A	0.49609375 µm	300 mm (11.811")	35 µm (0.001378")	< 2.5 µm (< 0.000098")
LRQ300DP-E01T3A	1.984375 µm	300 mm (11.811")	70 µm (0.002756")	< 3 µm (< 0.000118")

Part Number	Microstep Size (Default Resolution)	Travel Range	Accuracy (unidirectional)	Repeatability
LRQ300HP-E01T3A	0.1953125 µm	300 mm (11.811")	65 µm (0.002559")	< 5 µm (< 0.000197")
LRQ450AP-E01T3A	0.09921875 µm	450 mm (17.716")	135 µm (0.005315")	< 2.5 µm (< 0.000098")
LRQ450BP-E01T3A	0.49609375 µm	450 mm (17.716")	60 µm (0.002362")	< 2.5 µm (< 0.000098")
LRQ450DP-E01T3A	1.984375 µm	450 mm (17.716")	85 µm (0.003346")	< 3 µm (< 0.000118")
LRQ450HP-E01T3A	0.1953125 µm	450 mm (17.716")	95 µm (0.003740")	< 5 µm (< 0.000197")
LRQ600AP-E01T3A	0.09921875 µm	600 mm (23.622")	150 µm (0.005905")	< 2.5 µm (< 0.000098")
LRQ600BP-E01T3A	0.49609375 µm	600 mm (23.622")	90 µm (0.003543")	< 2.5 µm (< 0.000098")
LRQ600DP-E01T3A	1.984375 µm	600 mm (23.622")	100 µm (0.003937")	< 3 µm (< 0.000118")
LRQ600HP-E01T3A	0.1953125 µm	600 mm (23.622")	125 µm (0.004921")	< 5 µm (< 0.000197")

Part Number	Backlash	Maximum Speed	Minimum Speed	Speed Resolution
LRQ075AL-E01T3A	< 8 µm (< 0.000315")	54 mm/s (2.126"/s)	0.000061 mm/s (0.000002"/s)	0.000061 mm/s (0.000002"/s)
LRQ075BL-E01T3A	< 21 µm (< 0.000827")	270 mm/s (10.630"/s)	0.000303 mm/s (0.000012"/s)	0.000303 mm/s (0.000012"/s)
LRQ075DL-E01T3A	< 60 µm (< 0.002362")	840 mm/s (33.071"/s)	0.001211 mm/s (0.000048"/s)	0.001211 mm/s (0.000048"/s)
LRQ075HL-E01T3A	< 30 µm (< 0.001181")	110 mm/s (4.331"/s)	0.000119 mm/s (0.000005"/s)	0.000119 mm/s (0.000005"/s)
LRQ150AL-E01T3A	< 8 µm (< 0.000315")	54 mm/s (2.126"/s)	0.000061 mm/s (0.000002"/s)	0.000061 mm/s (0.000002"/s)
LRQ150BL-E01T3A	< 21 µm (< 0.000827")	270 mm/s (10.630"/s)	0.000303 mm/s (0.000012"/s)	0.000303 mm/s (0.000012"/s)
LRQ150DL-E01T3A	< 60 µm (< 0.002362")	840 mm/s (33.071"/s)	0.001211 mm/s (0.000048"/s)	0.001211 mm/s (0.000048"/s)
LRQ150HL-E01T3A	< 30 µm (< 0.001181")	110 mm/s (4.331"/s)	0.000119 mm/s (0.000005"/s)	0.000119 mm/s (0.000005"/s)
LRQ300AL-E01T3A	< 8 µm (< 0.000315")	54 mm/s (2.126"/s)	0.000061 mm/s (0.000002"/s)	0.000061 mm/s (0.000002"/s)
LRQ300BL-E01T3A	< 21 µm (< 0.000827")	270 mm/s (10.630"/s)	0.000303 mm/s (0.000012"/s)	0.000303 mm/s (0.000012"/s)
LRQ300DL-E01T3A	< 60 µm (< 0.002362")	840 mm/s (33.071"/s)	0.001211 mm/s (0.000048"/s)	0.001211 mm/s (0.000048"/s)
LRQ300HL-E01T3A	< 30 µm (< 0.001181")	110 mm/s (4.331"/s)	0.000119 mm/s (0.000005"/s)	0.000119 mm/s (0.000005"/s)
LRQ450AL-E01T3A	< 8 µm (< 0.000315")	54 mm/s (2.126"/s)	0.000061 mm/s (0.000002"/s)	0.000061 mm/s (0.000002"/s)
LRQ450BL-E01T3A	< 21 µm (< 0.000827")	270 mm/s (10.630"/s)	0.000303 mm/s (0.000012"/s)	0.000303 mm/s (0.000012"/s)
LRQ450DL-E01T3A	< 60 µm (< 0.002362")	840 mm/s (33.071"/s)	0.001211 mm/s (0.000048"/s)	0.001211 mm/s (0.000048"/s)
LRQ450HL-E01T3A	< 30 µm (< 0.001181")	110 mm/s (4.331"/s)	0.000119 mm/s (0.000005"/s)	0.000119 mm/s (0.000005"/s)
LRQ600AL-E01T3A	< 8 µm (< 0.000315")	54 mm/s (2.126"/s)	0.000061 mm/s (0.000002"/s)	0.000061 mm/s (0.000002"/s)
LRQ600BL-E01T3A	< 21 µm (< 0.000827")	270 mm/s (10.630"/s)	0.000303 mm/s (0.000012"/s)	0.000303 mm/s (0.000012"/s)

Part Number	Backlash	Maximum Speed	Minimum Speed	Speed Resolution
LRQ600DL-E01T3A	< 60 μm (< 0.002362")	840 mm/s (33.071"/s)	0.001211 mm/s (0.000048"/s)	0.001211 mm/s (0.000048"/s)
LRQ600HL-E01T3A	< 30 μm (< 0.001181")	110 mm/s (4.331"/s)	0.000119 mm/s (0.000005"/s)	0.000119 mm/s (0.000005"/s)
LRQ075AP-E01T3A	< 14 μm (< 0.000551")	54 mm/s (2.126"/s)	0.000061 mm/s (0.000002"/s)	0.000061 mm/s (0.000002"/s)
LRQ075BP-E01T3A	< 27 μm (< 0.001063")	270 mm/s (10.630"/s)	0.000303 mm/s (0.000012"/s)	0.000303 mm/s (0.000012"/s)
LRQ075DP-E01T3A	< 130 μm (< 0.005118")	840 mm/s (33.071"/s)	0.000303 mm/s (0.000012"/s)	0.000303 mm/s (0.000012"/s)
LRQ075HP-E01T3A	< 30 μm (< 0.001181")	110 mm/s (4.331"/s)	0.000119 mm/s (0.000005"/s)	0.000119 mm/s (0.000005"/s)
LRQ150AP-E01T3A	< 14 μm (< 0.000551")	54 mm/s (2.126"/s)	0.000061 mm/s (0.000002"/s)	0.000061 mm/s (0.000002"/s)
LRQ150BP-E01T3A	< 27 μm (< 0.001063")	270 mm/s (10.630"/s)	0.000303 mm/s (0.000012"/s)	0.000303 mm/s (0.000012"/s)
LRQ150DP-E01T3A	< 130 μm (< 0.005118")	840 mm/s (33.071"/s)	0.001211 mm/s (0.000048"/s)	0.001211 mm/s (0.000048"/s)
LRQ150HP-E01T3A	< 30 μm (< 0.001181")	110 mm/s (4.331"/s)	0.000119 mm/s (0.000005"/s)	0.000119 mm/s (0.000005"/s)
LRQ300AP-E01T3A	< 14 μm (< 0.000551")	54 mm/s (2.126"/s)	0.000061 mm/s (0.000002"/s)	0.000061 mm/s (0.000002"/s)
LRQ300BP-E01T3A	< 27 μm (< 0.001063")	270 mm/s (10.630"/s)	0.000303 mm/s (0.000012"/s)	0.000303 mm/s (0.000012"/s)
LRQ300DP-E01T3A	< 130 μm (< 0.005118")	840 mm/s (33.071"/s)	0.001211 mm/s (0.000048"/s)	0.001211 mm/s (0.000048"/s)
LRQ300HP-E01T3A	< 30 μm (< 0.001181")	110 mm/s (4.331"/s)	0.000119 mm/s (0.000005"/s)	0.000119 mm/s (0.000005"/s)
LRQ450AP-E01T3A	< 14 μm (< 0.000551")	54 mm/s (2.126"/s)	0.000061 mm/s (0.000002"/s)	0.000061 mm/s (0.000002"/s)
LRQ450BP-E01T3A	< 27 μm (< 0.001063")	270 mm/s (10.630"/s)	0.000303 mm/s (0.000012"/s)	0.000303 mm/s (0.000012"/s)
LRQ450DP-E01T3A	< 130 μm (< 0.005118")	840 mm/s (33.071"/s)	0.001211 mm/s (0.000048"/s)	0.001211 mm/s (0.000048"/s)
LRQ450HP-E01T3A	< 30 μm (< 0.001181")	110 mm/s (4.331"/s)	0.000119 mm/s (0.000005"/s)	0.000119 mm/s (0.000005"/s)
LRQ600AP-E01T3A	< 14 μm (< 0.000551")	54 mm/s (2.126"/s)	0.000061 mm/s (0.000002"/s)	0.000061 mm/s (0.000002"/s)
LRQ600BP-E01T3A	< 27 μm (< 0.001063")	270 mm/s (10.630"/s)	0.000303 mm/s (0.000012"/s)	0.000303 mm/s (0.000012"/s)
LRQ600DP-E01T3A	< 130 μm (< 0.005118")	840 mm/s (33.071"/s)	0.001211 mm/s (0.000048"/s)	0.001211 mm/s (0.000048"/s)
LRQ600HP-E01T3A	< 30 μm (< 0.001181")	110 mm/s (4.331"/s)	0.000119 mm/s (0.000005"/s)	0.000119 mm/s (0.000005"/s)

Part Number	Peak Thrust	Back-driving Force*	Maximum Continuous Thrust	Vertical Runout
LRQ075AL-E01T3A	230 N (51.6 lb)	Non-back-driving	100 N (22.4 lb)	< 20 μm (< 0.000787")
LRQ075BL-E01T3A	150 N (33.6 lb)	93 N (20.9 lb) ($\pm 30\%$)	100 N (22.4 lb)	< 20 μm (< 0.000787")

Part Number	Peak Thrust	Back-driving Force*	Maximum Continuous Thrust	Vertical Runout
LRQ075DL-E01T3A	35 N (7.8 lb)	14 N (3.1 lb) (± 30%)	35 N (7.8 lb)	< 20 µm (< 0.000787")
LRQ075HL-E01T3A	500 N (112.1 lb)	93 N (20.9 lb) (± 30%)	200 N (44.9 lb)	< 20 µm (< 0.000787")
LRQ150AL-E01T3A	230 N (51.6 lb)	Non-back-driving	100 N (22.4 lb)	< 25 µm (< 0.000984")
LRQ150BL-E01T3A	150 N (33.6 lb)	93 N (20.9 lb) (± 30%)	100 N (22.4 lb)	< 25 µm (< 0.000984")
LRQ150DL-E01T3A	35 N (7.8 lb)	14 N (3.1 lb) (± 30%)	35 N (7.8 lb)	< 25 µm (< 0.000984")
LRQ150HL-E01T3A	500 N (112.1 lb)	93 N (20.9 lb) (± 30%)	200 N (44.9 lb)	< 25 µm (< 0.000984")
LRQ300AL-E01T3A	230 N (51.6 lb)	Non-back-driving	100 N (22.4 lb)	< 35 µm (< 0.001378")
LRQ300BL-E01T3A	150 N (33.6 lb)	93 N (20.9 lb) (± 30%)	100 N (22.4 lb)	< 35 µm (< 0.001378")
LRQ300DL-E01T3A	35 N (7.8 lb)	14 N (3.1 lb) (± 30%)	35 N (7.8 lb)	< 35 µm (< 0.001378")
LRQ300HL-E01T3A	500 N (112.1 lb)	93 N (20.9 lb) (± 30%)	200 N (44.9 lb)	< 35 µm (< 0.001378")
LRQ450AL-E01T3A	230 N (51.6 lb)	Non-back-driving	100 N (22.4 lb)	< 45 µm (< 0.001772")
LRQ450BL-E01T3A	150 N (33.6 lb)	93 N (20.9 lb) (± 30%)	100 N (22.4 lb)	< 45 µm (< 0.001772")
LRQ450DL-E01T3A	35 N (7.8 lb)	14 N (3.1 lb) (± 30%)	35 N (7.8 lb)	< 45 µm (< 0.001772")
LRQ450HL-E01T3A	500 N (112.1 lb)	93 N (20.9 lb) (± 30%)	200 N (44.9 lb)	< 45 µm (< 0.001772")
LRQ600AL-E01T3A	230 N (51.6 lb)	Non-back-driving	100 N (22.4 lb)	< 75 µm (< 0.002953")
LRQ600BL-E01T3A	150 N (33.6 lb)	93 N (20.9 lb) (± 30%)	100 N (22.4 lb)	< 75 µm (< 0.002953")
LRQ600DL-E01T3A	35 N (7.8 lb)	14 N (3.1 lb) (± 30%)	35 N (7.8 lb)	< 75 µm (< 0.002953")
LRQ600HL-E01T3A	500 N (112.1 lb)	93 N (20.9 lb) (± 30%)	200 N (44.9 lb)	< 75 µm (< 0.002953")
LRQ075AP-E01T3A	230 N (51.6 lb)	Non-back-driving	100 N (22.4 lb)	< 20 µm (< 0.000787")
LRQ075BP-E01T3A	150 N (33.6 lb)	123 N (27.6 lb) (± 30%)	100 N (22.4 lb)	< 20 µm (< 0.000787")
LRQ075DP-E01T3A	35 N (7.8 lb)	45 N (10.1 lb) (± 30%)	35 N (7.8 lb)	< 20 µm (< 0.000787")
LRQ075HP-E01T3A	500 N (112.1 lb)	123 N (27.6 lb) (± 30%)	200 N (44.9 lb)	< 20 µm (< 0.000787")
LRQ150AP-E01T3A	230 N (51.6 lb)	Non-back-driving	100 N (22.4 lb)	< 25 µm (< 0.000984")
LRQ150BP-E01T3A	150 N (33.6 lb)	123 N (27.6 lb) (± 30%)	100 N (22.4 lb)	< 25 µm (< 0.000984")
LRQ150DP-E01T3A	35 N (7.8 lb)	45 N (10.1 lb) (± 30%)	35 N (7.8 lb)	< 25 µm (< 0.000984")
LRQ150HP-E01T3A	500 N (112.1 lb)	123 N (27.6 lb) (± 30%)	200 N (44.9 lb)	< 25 µm (< 0.000984")
LRQ300AP-E01T3A	230 N (51.6 lb)	Non-back-driving	100 N (22.4 lb)	< 35 µm (< 0.001378")

Part Number	Peak Thrust	Back-driving Force*	Maximum Continuous Thrust	Vertical Runout
LRQ300BP-E01T3A	150 N (33.6 lb)	123 N (27.6 lb) (± 30%)	100 N (22.4 lb)	< 35 µm (< 0.001378")
LRQ300DP-E01T3A	35 N (7.8 lb)	45 N (10.1 lb) (± 30%)	35 N (7.8 lb)	< 35 µm (< 0.001378")
LRQ300HP-E01T3A	500 N (112.1 lb)	123 N (27.6 lb) (± 30%)	200 N (44.9 lb)	< 35 µm (< 0.001378")
LRQ450AP-E01T3A	230 N (51.6 lb)	Non-back-driving	100 N (22.4 lb)	< 45 µm (< 0.001772")
LRQ450BP-E01T3A	150 N (33.6 lb)	123 N (27.6 lb) (± 30%)	100 N (22.4 lb)	< 45 µm (< 0.001772")
LRQ450DP-E01T3A	35 N (7.8 lb)	45 N (10.1 lb) (± 30%)	35 N (7.8 lb)	< 45 µm (< 0.001772")
LRQ450HP-E01T3A	500 N (112.1 lb)	123 N (27.6 lb) (± 30%)	200 N (44.9 lb)	< 45 µm (< 0.001772")
LRQ600AP-E01T3A	230 N (51.6 lb)	Non-back-driving	100 N (22.4 lb)	< 75 µm (< 0.002953")
LRQ600BP-E01T3A	150 N (33.6 lb)	123 N (27.6 lb) (± 30%)	100 N (22.4 lb)	< 75 µm (< 0.002953")
LRQ600DP-E01T3A	35 N (7.8 lb)	45 N (10.1 lb) (± 30%)	35 N (7.8 lb)	< 75 µm (< 0.002953")
LRQ600HP-E01T3A	500 N (112.1 lb)	123 N (27.6 lb) (± 30%)	200 N (44.9 lb)	< 75 µm (< 0.002953")

Part Number	Horizontal Runout	Pitch	Roll	Yaw
LRQ075AL-E01T3A	< 20 µm (< 0.000787")	0.025° (0.436 mrad)	0.015° (0.262 mrad)	0.02° (0.349 mrad)
LRQ075BL-E01T3A	< 20 µm (< 0.000787")	0.025° (0.436 mrad)	0.015° (0.262 mrad)	0.02° (0.349 mrad)
LRQ075DL-E01T3A	< 20 µm (< 0.000787")	0.025° (0.436 mrad)	0.015° (0.262 mrad)	0.02° (0.349 mrad)
LRQ075HL-E01T3A	< 20 µm (< 0.000787")	0.025° (0.436 mrad)	0.015° (0.262 mrad)	0.02° (0.349 mrad)
LRQ150AL-E01T3A	< 20 µm (< 0.000787")	0.03° (0.523 mrad)	0.015° (0.262 mrad)	0.02° (0.349 mrad)
LRQ150BL-E01T3A	< 20 µm (< 0.000787")	0.03° (0.523 mrad)	0.015° (0.262 mrad)	0.02° (0.349 mrad)
LRQ150DL-E01T3A	< 20 µm (< 0.000787")	0.03° (0.523 mrad)	0.015° (0.262 mrad)	0.02° (0.349 mrad)
LRQ150HL-E01T3A	< 20 µm (< 0.000787")	0.03° (0.523 mrad)	0.015° (0.262 mrad)	0.02° (0.349 mrad)
LRQ300AL-E01T3A	< 30 µm (< 0.001181")	0.034° (0.593 mrad)	0.015° (0.262 mrad)	0.03° (0.523 mrad)
LRQ300BL-E01T3A	< 30 µm (< 0.001181")	0.034° (0.593 mrad)	0.015° (0.262 mrad)	0.03° (0.523 mrad)
LRQ300DL-E01T3A	< 30 µm (< 0.001181")	0.034° (0.593 mrad)	0.015° (0.262 mrad)	0.03° (0.523 mrad)
LRQ300HL-E01T3A	< 30 µm (< 0.001181")	0.034° (0.593 mrad)	0.015° (0.262 mrad)	0.03° (0.523 mrad)
LRQ450AL-E01T3A	< 40 µm (< 0.001575")	0.04° (0.698 mrad)	0.025° (0.436 mrad)	0.04° (0.698 mrad)
LRQ450BL-E01T3A	< 40 µm (< 0.001575")	0.04° (0.698 mrad)	0.025° (0.436 mrad)	0.04° (0.698 mrad)
LRQ450DL-E01T3A	< 40 µm (< 0.001575")	0.04° (0.698 mrad)	0.025° (0.436 mrad)	0.04° (0.698 mrad)
LRQ450HL-E01T3A	< 40 µm (< 0.001575")	0.04° (0.698 mrad)	0.025° (0.436 mrad)	0.04° (0.698 mrad)
LRQ600AL-E01T3A	< 60 µm (< 0.002362")	0.045° (0.785 mrad)	0.035° (0.611 mrad)	0.04° (0.698 mrad)
LRQ600BL-E01T3A	< 60 µm (< 0.002362")	0.045° (0.785 mrad)	0.035° (0.611 mrad)	0.04° (0.698 mrad)
LRQ600DL-E01T3A	< 60 µm (< 0.002362")	0.045° (0.785 mrad)	0.035° (0.611 mrad)	0.04° (0.698 mrad)
LRQ600HL-E01T3A	< 60 µm (< 0.002362")	0.045° (0.785 mrad)	0.035° (0.611 mrad)	0.04° (0.698 mrad)
LRQ075AP-E01T3A	< 20 µm (< 0.000787")	0.025° (0.436 mrad)	0.015° (0.262 mrad)	0.02° (0.349 mrad)
LRQ075BP-E01T3A	< 20 µm (< 0.000787")	0.025° (0.436 mrad)	0.015° (0.262 mrad)	0.02° (0.349 mrad)
LRQ075DP-E01T3A	< 20 µm (< 0.000787")	0.025° (0.436 mrad)	0.015° (0.262 mrad)	0.02° (0.349 mrad)

Part Number	Horizontal Runout	Pitch	Roll	Yaw
LRQ075HP-E01T3A	< 20 µm (< 0.000787")	0.025° (0.436 mrad)	0.015° (0.262 mrad)	0.02° (0.349 mrad)
LRQ150AP-E01T3A	< 20 µm (< 0.000787")	0.03° (0.523 mrad)	0.015° (0.262 mrad)	0.02° (0.349 mrad)
LRQ150BP-E01T3A	< 20 µm (< 0.000787")	0.03° (0.523 mrad)	0.015° (0.262 mrad)	0.02° (0.349 mrad)
LRQ150DP-E01T3A	< 20 µm (< 0.000787")	0.03° (0.523 mrad)	0.015° (0.262 mrad)	0.02° (0.349 mrad)
LRQ150HP-E01T3A	< 20 µm (< 0.000787")	0.03° (0.523 mrad)	0.015° (0.262 mrad)	0.02° (0.349 mrad)
LRQ300AP-E01T3A	< 30 µm (< 0.001181")	0.034° (0.593 mrad)	0.015° (0.262 mrad)	0.03° (0.523 mrad)
LRQ300BP-E01T3A	< 30 µm (< 0.001181")	0.034° (0.593 mrad)	0.015° (0.262 mrad)	0.03° (0.523 mrad)
LRQ300DP-E01T3A	< 30 µm (< 0.001181")	0.034° (0.593 mrad)	0.015° (0.262 mrad)	0.03° (0.523 mrad)
LRQ300HP-E01T3A	< 30 µm (< 0.001181")	0.034° (0.593 mrad)	0.015° (0.262 mrad)	0.03° (0.523 mrad)
LRQ450AP-E01T3A	< 40 µm (< 0.001575")	0.04° (0.698 mrad)	0.025° (0.436 mrad)	0.04° (0.698 mrad)
LRQ450BP-E01T3A	< 40 µm (< 0.001575")	0.04° (0.698 mrad)	0.025° (0.436 mrad)	0.04° (0.698 mrad)
LRQ450DP-E01T3A	< 40 µm (< 0.001575")	0.04° (0.698 mrad)	0.025° (0.436 mrad)	0.04° (0.698 mrad)
LRQ450HP-E01T3A	< 40 µm (< 0.001575")	0.04° (0.698 mrad)	0.025° (0.436 mrad)	0.04° (0.698 mrad)
LRQ600AP-E01T3A	< 60 µm (< 0.002362")	0.045° (0.785 mrad)	0.035° (0.611 mrad)	0.04° (0.698 mrad)
LRQ600BP-E01T3A	< 60 µm (< 0.002362")	0.045° (0.785 mrad)	0.035° (0.611 mrad)	0.04° (0.698 mrad)
LRQ600DP-E01T3A	< 60 µm (< 0.002362")	0.045° (0.785 mrad)	0.035° (0.611 mrad)	0.04° (0.698 mrad)
LRQ600HP-E01T3A	< 60 µm (< 0.002362")	0.045° (0.785 mrad)	0.035° (0.611 mrad)	0.04° (0.698 mrad)

Part Number	Linear Motion Per Motor Rev	Mechanical Drive System	Weight
LRQ075AL-E01T3A	1.27 mm (0.050")	Precision lead screw	2.15 kg (4.740 lb)
LRQ075BL-E01T3A	6.35 mm (0.250")	Precision lead screw	2.15 kg (4.740 lb)
LRQ075DL-E01T3A	25.4 mm (1.000")	Precision lead screw	2.15 kg (4.740 lb)
LRQ075HL-E01T3A	2.5 mm (0.098")	Precision ball screw	2.15 kg (4.740 lb)
LRQ150AL-E01T3A	1.27 mm (0.050")	Precision lead screw	2.52 kg (5.556 lb)
LRQ150BL-E01T3A	6.35 mm (0.250")	Precision lead screw	2.52 kg (5.556 lb)
LRQ150DL-E01T3A	25.4 mm (1.000")	Precision lead screw	2.52 kg (5.556 lb)
LRQ150HL-E01T3A	2.5 mm (0.098")	Precision ball screw	2.52 kg (5.556 lb)
LRQ300AL-E01T3A	1.27 mm (0.050")	Precision lead screw	3.28 kg (7.231 lb)
LRQ300BL-E01T3A	6.35 mm (0.250")	Precision lead screw	3.28 kg (7.231 lb)
LRQ300DL-E01T3A	25.4 mm (1.000")	Precision lead screw	3.28 kg (7.231 lb)
LRQ300HL-E01T3A	2.5 mm (0.098")	Precision ball screw	3.28 kg (7.231 lb)
LRQ450AL-E01T3A	1.27 mm (0.050")	Precision lead screw	4.03 kg (8.885 lb)
LRQ450BL-E01T3A	6.35 mm (0.250")	Precision lead screw	4.03 kg (8.885 lb)
LRQ450DL-E01T3A	25.4 mm (1.000")	Precision lead screw	4.03 kg (8.885 lb)
LRQ450HL-E01T3A	2.5 mm (0.098")	Precision ball screw	4.03 kg (8.885 lb)
LRQ600AL-E01T3A	1.27 mm (0.050")	Precision lead screw	4.74 kg (10.450 lb)
LRQ600BL-E01T3A	6.35 mm (0.250")	Precision lead screw	4.74 kg (10.450 lb)
LRQ600DL-E01T3A	25.4 mm (1.000")	Precision lead screw	4.74 kg (10.450 lb)
LRQ600HL-E01T3A	2.5 mm (0.098")	Precision ball screw	4.74 kg (10.450 lb)
LRQ075AP-E01T3A	1.27 mm (0.050")	Precision lead screw	2.29 kg (5.049 lb)
LRQ075BP-E01T3A	6.35 mm (0.250")	Precision lead screw	2.29 kg (5.049 lb)
LRQ075DP-E01T3A	6.35 mm (0.250")	Precision lead screw	2.29 kg (5.049 lb)
LRQ075HP-E01T3A	2.5 mm (0.098")	Precision ball screw	2.29 kg (5.049 lb)

Part Number	Linear Motion Per Motor Rev	Mechanical Drive System	Weight
LRQ150AP-E01T3A	1.27 mm (0.050")	Precision lead screw	2.66 kg (5.864 lb)
LRQ150BP-E01T3A	6.35 mm (0.250")	Precision lead screw	2.66 kg (5.864 lb)
LRQ150DP-E01T3A	25.4 mm (1.000")	Precision lead screw	2.66 kg (5.864 lb)
LRQ150HP-E01T3A	2.5 mm (0.098")	Precision ball screw	2.66 kg (5.864 lb)
LRQ300AP-E01T3A	1.27 mm (0.050")	Precision lead screw	3.42 kg (7.540 lb)
LRQ300BP-E01T3A	6.35 mm (0.250")	Precision lead screw	3.42 kg (7.540 lb)
LRQ300DP-E01T3A	25.4 mm (1.000")	Precision lead screw	3.42 kg (7.540 lb)
LRQ300HP-E01T3A	2.5 mm (0.098")	Precision ball screw	3.42 kg (7.540 lb)
LRQ450AP-E01T3A	1.27 mm (0.050")	Precision lead screw	4.17 kg (9.193 lb)
LRQ450BP-E01T3A	6.35 mm (0.250")	Precision lead screw	4.17 kg (9.193 lb)
LRQ450DP-E01T3A	25.4 mm (1.000")	Precision lead screw	4.17 kg (9.193 lb)
LRQ450HP-E01T3A	2.5 mm (0.098")	Precision ball screw	4.17 kg (9.193 lb)
LRQ600AP-E01T3A	1.27 mm (0.050")	Precision lead screw	4.88 kg (10.759 lb)
LRQ600BP-E01T3A	6.35 mm (0.250")	Precision lead screw	4.88 kg (10.759 lb)
LRQ600DP-E01T3A	25.4 mm (1.000")	Precision lead screw	4.88 kg (10.759 lb)
LRQ600HP-E01T3A	2.5 mm (0.098")	Precision ball screw	4.88 kg (10.759 lb)

Thrust Speed Performance

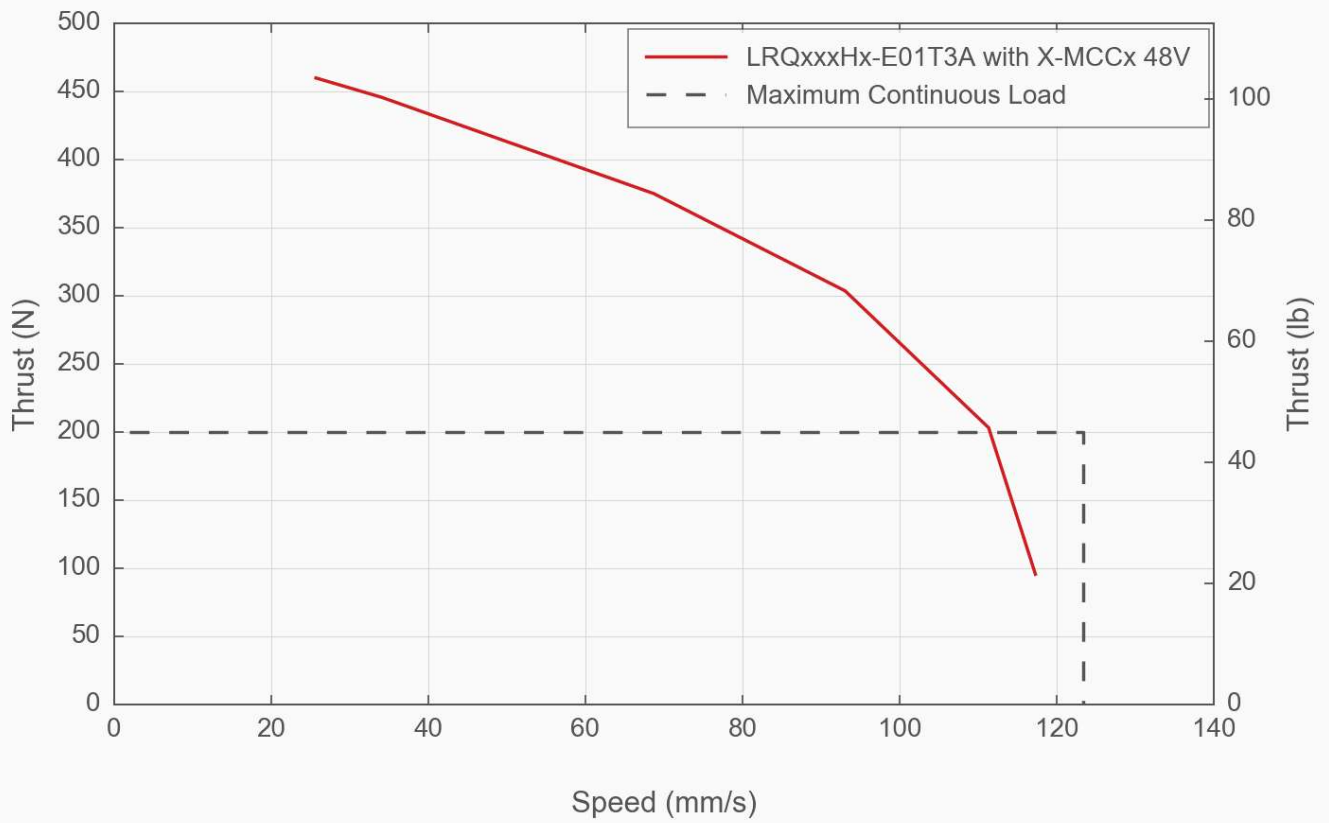

Thrust Speed Performance

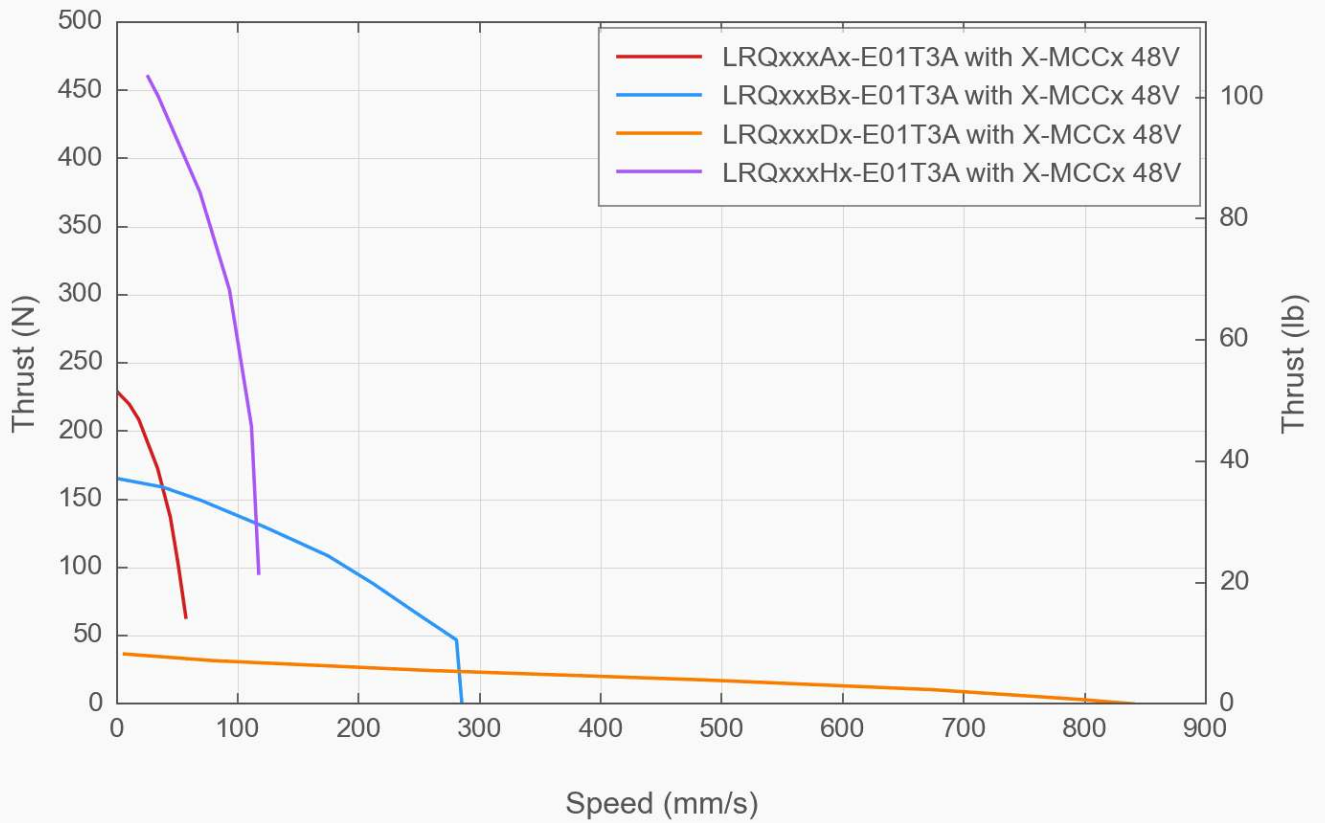

Thrust Speed Performance

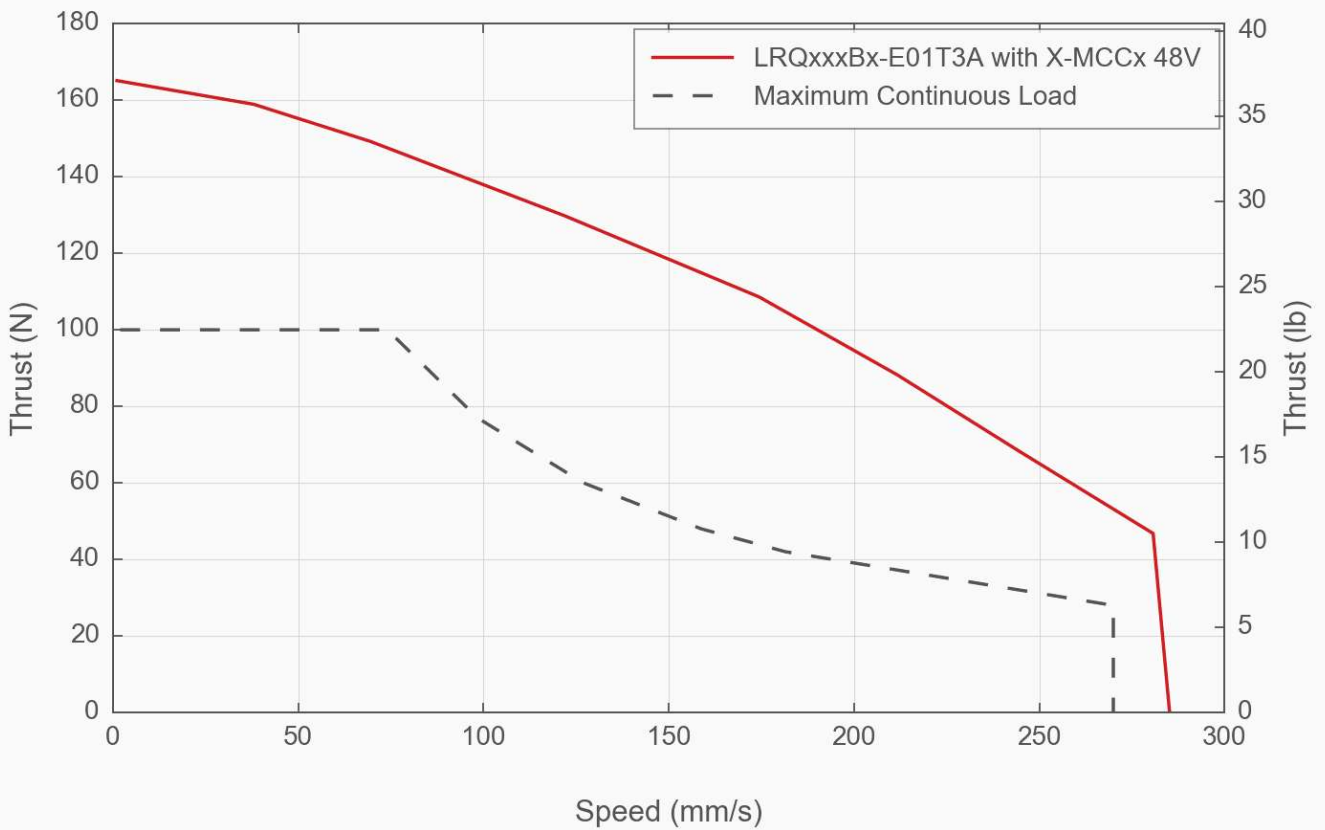

Thrust Speed Performance

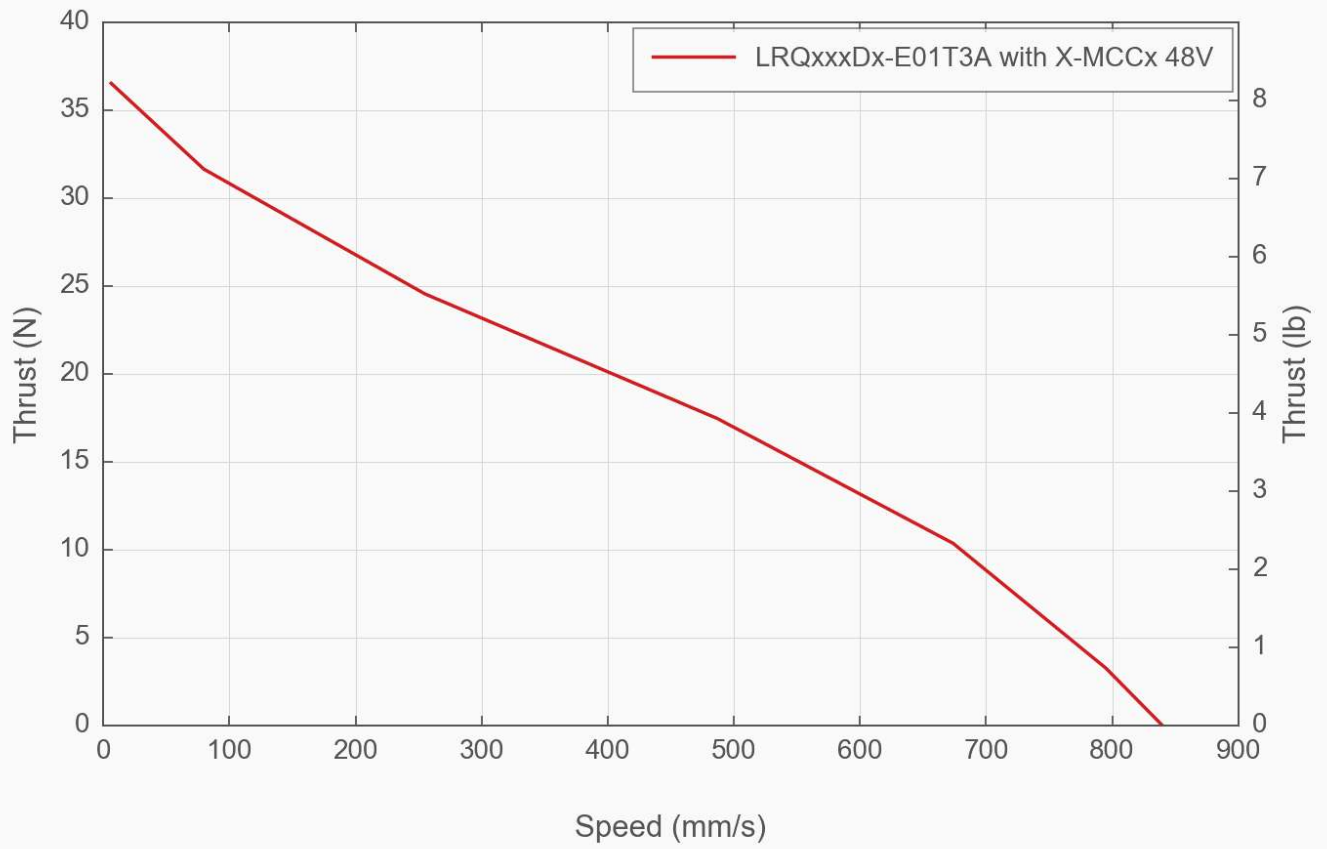

Thrust Speed Performance

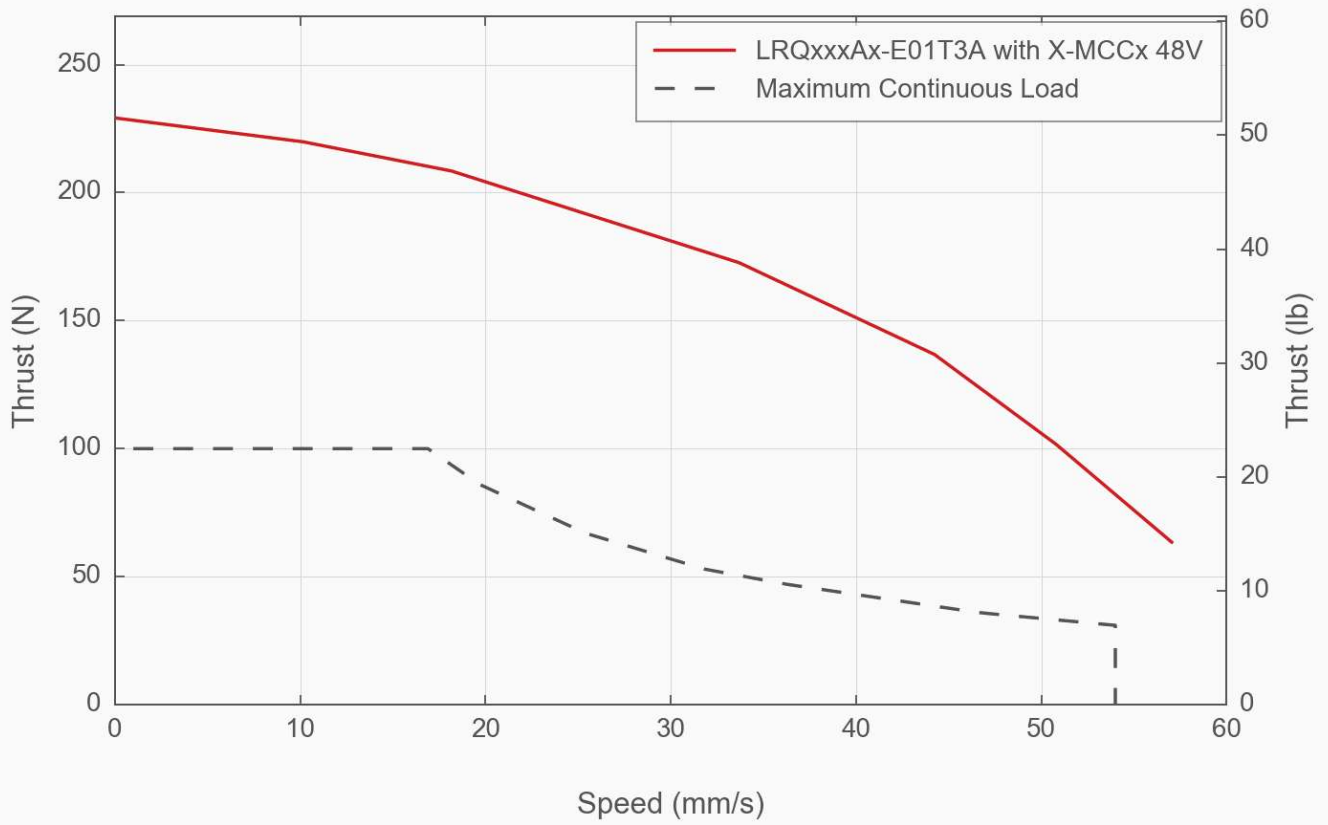

LRQ Linear Bearing Lifetime

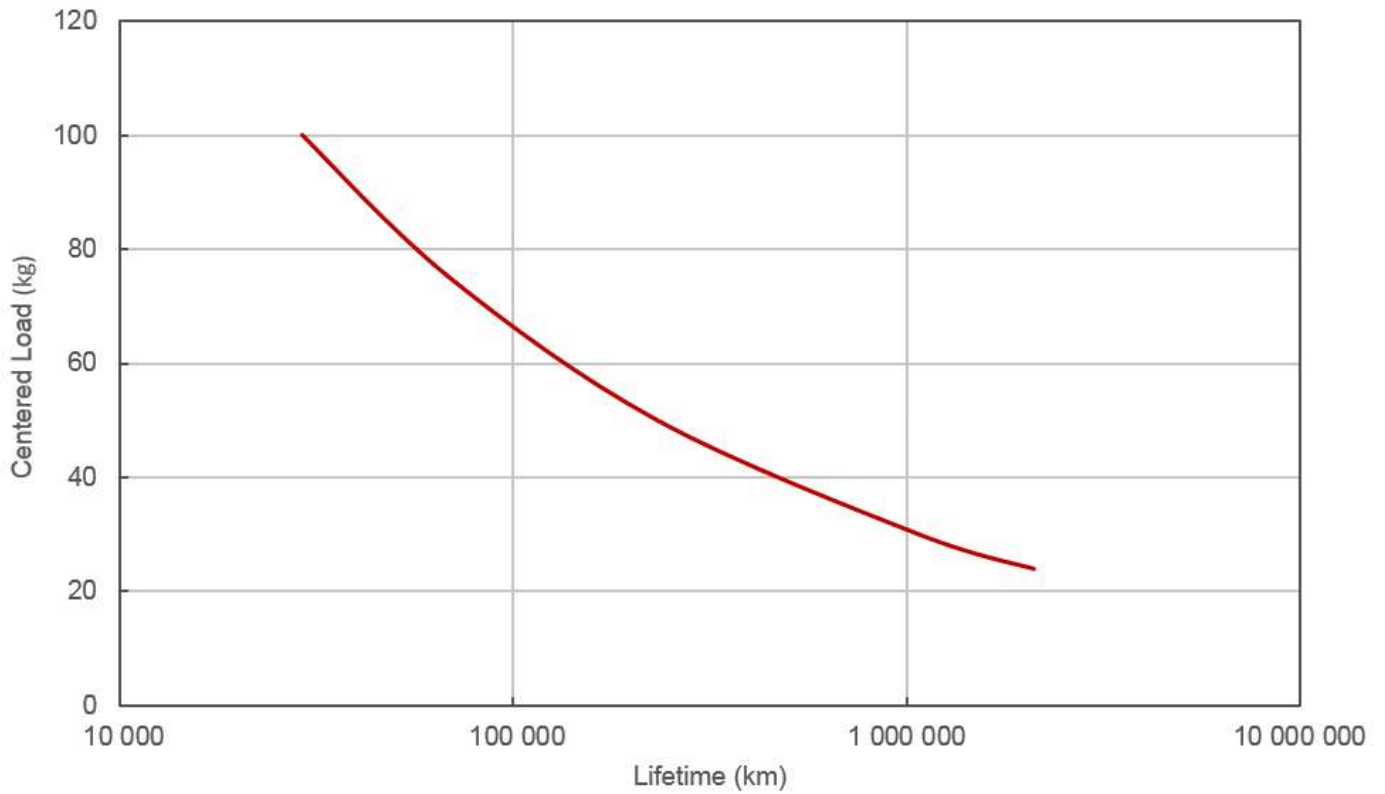

Product Change Notices

Click [here](#) to view the current product change notices and subscribe to future change notifications.