

LRT-EC Series User's Manual

High load motorized linear stages with built-in motor encoders, dust covers, and optional brakes



Disclaimer

Zaber's products are not intended for use in any critical medical, aviation, or military applications or situations where a product's use or failure could cause personal injury, death, or damage to property. Zaber disclaims any warranty of fitness for a particular purpose. The user of this product agrees to [Zaber's general terms and conditions of sale](#).

Precautions

Zaber's autodetect peripheral axes are designed to be used effortlessly with Zaber's line of autodetect controllers. The LRT-EC includes onboard memory that allows Zaber's controllers to autodetect the model and set reasonable parameters. See the [Protocol Manual](#) for more information on how to modify the settings. Damage to the axis may result if the settings are not correct. To use your Zaber peripheral with a third-party controller, review the motor, sensor, and encoder specifications and pin-outs carefully.

Zaber's motion control devices are precision instruments and must be handled with care. In particular, moving parts must be treated with care. Avoid axial loads in excess of the rated thrust load, axial and radial impact, dust and other contaminants and damage to the lead screw thread. These will reduce the performance of the device below stated specifications.

⚠ Caution: The motor in this device can exceed 60° C during normal operation and become hot enough to cause burns. Take precautions to prevent contact with the motor.

⚠ Dynamic Stops: The power-off brake is intended to prevent damage and maintain the position of a static load in the event of a power loss. Precautions should be taken to avoid dynamic braking when possible, as this may reduce brake lifetime.

💡 Space Constraints: Plastic covers on the power-off brake stick outside the motor form factor and may be removed when space is limited, but should remain attached otherwise.

💡 Dust Generation: Brake pads may generate small amounts of dust particulate over their lifetime of use.

Conventions used throughout this document

- Fixed width type indicates communication to and from a device. The `␣` symbol indicates a carriage return, which can be achieved by pressing enter when using a terminal program.
- An [ASCII command](#) followed by (T:xx) indicates a legacy T-Series [Binary Protocol](#) command that achieves the same result. For example, `move abs 10000 (T:20:10000)` shows that a move abs ASCII command can also be achieved with Binary command number 20.

Not all ASCII commands have an equivalent Binary counterpart.

Device Overview

AutoDetect

Your LRT-EC peripheral is equipped with AutoDetect, a feature that allows a Zaber controller to automatically configure its settings for the peripheral when it is connected.

💡 Important: The controller should always be powered down before disconnecting or connecting your LRT-EC peripheral.

To connect the peripheral to a controller:

- Power off the controller.
- Connect the LRT-EC peripheral.
- Power on the controller.
- The controller will activate the peripheral shortly after it is powered on.

Controller Compatibility: X-MCC (revision 2+) with firmware (FW 7.34+) is required for the operation of devices with a power-off brake. See the Zaber controller user manual for more details on peripheral activation and control.

Connectors

Recommended controller(s) for your LRT-EC peripheral are provided in the product specifications. Zaber's controllers and peripherals are designed for ease of use when used together. Optimal settings for each peripheral are automatically detected by Zaber's controllers when the device is connected.

For reference, the pinout for the peripheral cable connectors is shown below:

Pinout for D-sub 15 Connectors (peripherals) without brakes

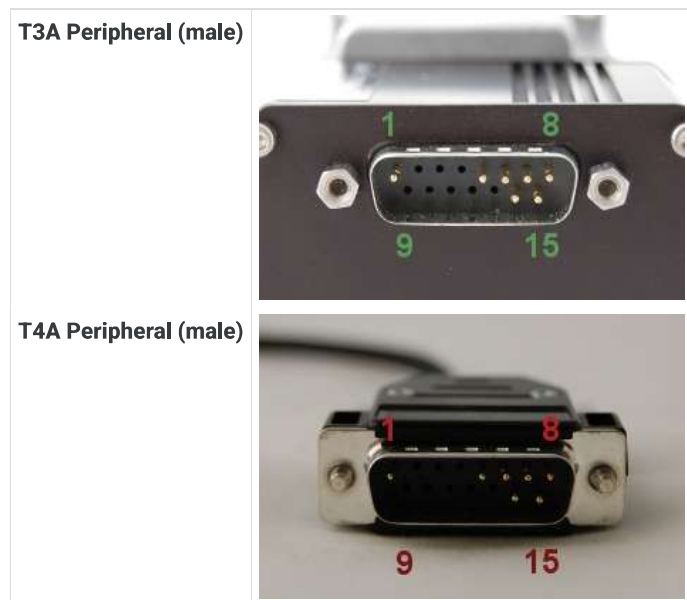

Pin #	Function
1	+5V for Limits & Encoder
2	AutoDetect Data
3	<i>reserved</i>
4	Away Sensor
5	Home Sensor
6	Ground
7	Motor B1
8	Motor A1
9	AutoDetect Clock
10	Encoder A
11	Encoder B
12	Encoder Index
13	Ground
14	Motor B2
15	Motor A2

Not all pins are used for all models

Pinout for D-sub 26 Connectors (peripherals) for Brake-Equipped Products

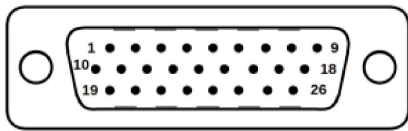

Male High Density D-sub26 Connector
Motor and Sensor Interface

Pin	Description	Pin	Description
1	AutoDetect Clock	14	Single-ended Encoder Index
2	AutoDetect Data	15	+5V
3	N.C.	16	Ground
4	N.C.	17	Brake-
5	Home Limit Sensor	18	Motor B1 (<i>N.C. for T12A devices</i>)
6	N.C.	19	N.C.
7	Ground	20	N.C.
8	Motor A2 (<i>N.C. for T12A devices</i>)	21	N.C.
9	Motor A1 (<i>N.C. for T12A devices</i>)	22	Encoder A
10	N.C.	23	Encoder B
11	N.C.	24	N.C.
12	N.C.	25	Brake+
13	N.C.	26	Motor B2 (<i>N.C. for T12A devices</i>)

NOTE: All hall sensor signals (for limits or motor phase) are open collector and require a pull-up on the controller.

NOTE: All single-ended encoder inputs are non-isolated 5V TTL lines.

Alternate Controllers

The LRT-EC can be controlled by any 2-phase stepper motor controller with limit sensor and appropriate encoder and brake input. **We do not recommend using your own controller unless you are familiar with how to control a stepper motor with hall sensor limit switches, encoders, and power-off brakes.** Improper use can result in excessive heat generated by the device, potentially causing harm to operators or damage to the system. Damage to the device due to incorrect wiring is not covered by warranty.

Motors & Encoders

For motor and encoder information see the [LRT-EC product page](#)

Limit Sensors

Hall effect sensors are used in the LRT-EC as home sensors. The Hall sensors used are part number A1120LLHLT-T made by Allegro. [Click here for data sheet](#). Your controller should be configured so the stage stops immediately (quick deceleration) when the sensors are triggered.

- PCB wire colour code:
 - 5 Vdc input - red
 - Home signal - yellow
 - Away signal - white
 - Ground - black

The Hall sensor has an open-collector output. The default output is high impedance when the Hall sensor is not active. When the sensor detects a magnet, the Hall sensor pulls the output low to ground.

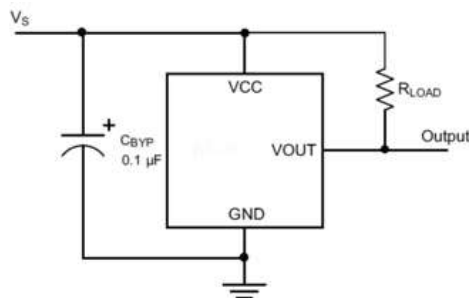

If you are not using a Zaber controller, ensure that your controller has a pull-up resistor on the output line of each Hall sensor as shown in the diagram. The bypass capacitor is optional, but may help to eliminate false triggering in noisy environments. The typical value for the pull-up resistor (R_{LOAD}) is 10 k Ω and for the bypass capacitor is 0.1 uF to 1 uF. The larger the capacitance, the better the noise filtering but the slower the response time.

Power-off Brake

It is necessary to follow the recommended values for excitation and hold voltages:

- The initial excitation voltage of 24 V should be applied for at least 100 ms to ensure the power-off brake is opened.
- A hold voltage of 10 V can then be applied to reduce excess heating of the brake.
- When open, the brake will consume ~2 watts to remain open.

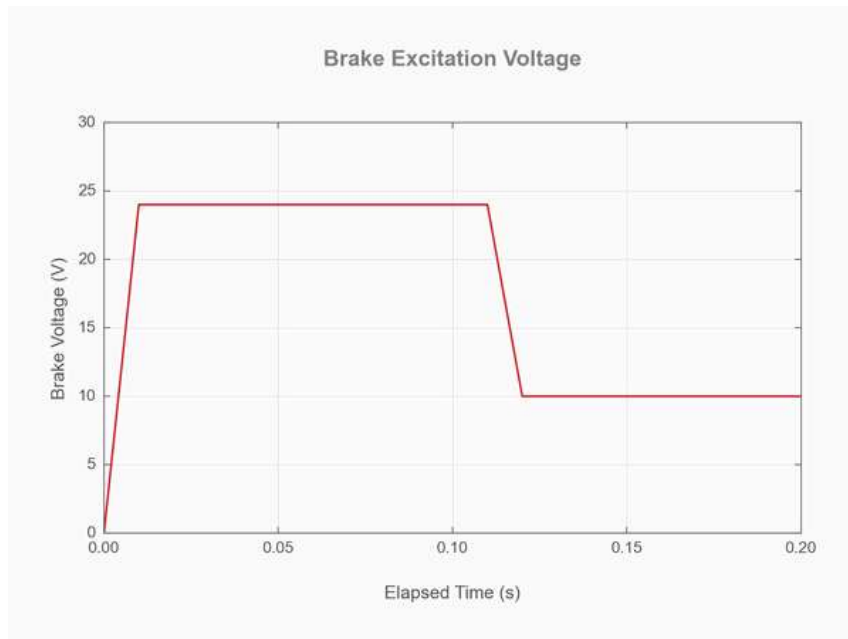

Installation

Physical Installation

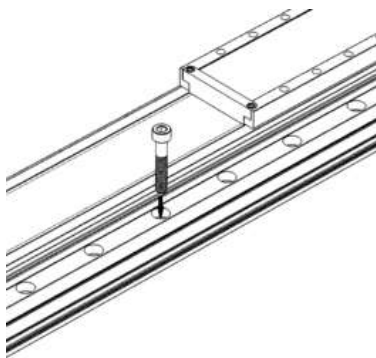

Secure stages with M6 (or 1/4"-20) socket cap screws, 35 mm or longer.

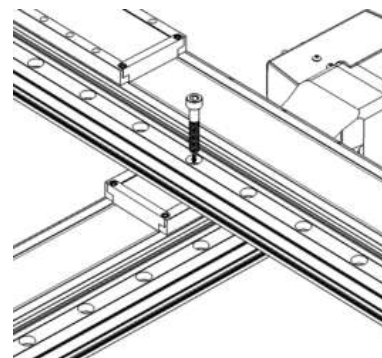

Two stages can be mounted directly in XY configuration.

Tip: To obtain the best pitch, roll, yaw and runout accuracy, mount the stage to a known flat, stiff surface. Our tests were performed on a granite table, grade A flatness.

Warning: Tipping Hazard! Ensure stage is fastened to a secure surface before mounting load on carriage. An unmounted stage with a load presents a tipping hazard. Ensure loads are mounted securely to the carriage of the stage.

Warning: Back-driving Hazard! When mounting back-drivable stages vertically, use a power-off brake and do not exceed the "Maximum Axial Brake Force" listed below. Exceeding this load could damage the device and cause injury.

Drive Screw Version	Back-driving Force (N)	Maximum Axial Brake Force (N)
A	Non-back-driving	N/A
B	420	600
D	40	180
H	157	1200

LRT-AE Installation

The LRT-AE version contains a linear encoder scale and flat flex cable on one side. It can be mounted in all orientations except the following. These orientations can cause the encoder flex cable to migrate out of its intended position:



LRT-AE Mounting

This orientation can cause the flex cable to bunch up, especially in stages over 500 mm travel.



LRT-AE Mounting

This orientation can cause the flex cable to migrate out of its cover, especially in stages over 500 mm travel.

■

Maintenance

Many factors affect the lifetime of the grease and bearings including duty cycle, environment, travel length, stage orientation, and loading configuration. As a general guideline for usage in a clean office environment, the recommended re-lubrication interval is 250 km with an inspection after every 1500 hours of continuous operation. Inspection should be done by wiping a bearing rail with a clean, lint-free wipe and ensuring that there is clean, wetted grease present.

Harsh environment, short travel, vertically oriented, and high duty cycle applications require more frequent re-lubrication and inspection. Contact an Applications Engineer to discuss your application for more specific recommendations.

Short travel can cause an insufficient distribution of lubricant amongst the rolling elements of the bearing system. For recirculating bearing guide types, short travel is equal to or less than the length of the carriage. For crossed-roller bearing guide types, short travel is equal to or less than twice the spacing of the rolling elements (typically 5-6 mm). If your application is considered short travel, it is recommended to occasionally drive the stage throughout its full travel range to maintain an even lubrication film over the entire guide surface. More frequent re-lubrication and inspection may be required in these applications.

Contact [Zaber support](#) for [relubrication kit SG133](#). We recommend using Shell Gadus S2 V220 2 or similar lithium thickened petroleum grease.

Lead Screw Noise

If your stage develops a chirping or squealing sound while moving, especially at high speed, lubricating the lead screw will usually solve the problem. We recommend Super Lube 52004 Synthetic Lightweight Oil.

- Remove the dust cover by following the instructions in the next section
- Move the carriage to the away position.
- Wipe the lead screw clean of any dust or debris before application.
- Apply a small line of Super Lube down the whole length of the lead screw. Be careful not to get any oil into the lead nut as it can interfere with the anti-backlash mechanism.
- Move the carriage slowly (speed = ~60 rpm or 21,000 Zaber units) to the home position to evenly distribute the oil.
- Follow the instructions below to reinstall the rigid cover.

■



Applying Super Lube to lead screw

■



This is a good amount of oil

■

Remove dust cover

⚠ Careful, dust cover edges are sharp!

⚠ Pinch Hazard! You will need to move the stage with the power on while greasing. Be careful not to squish anything, especially fingers or hands, between the carriage and the end plates.

■

■



Remove the dust cover clamps at each end of the stage by removing their M3 screws.



Remove the carriage ramps by removing their screws.



Slide out the carriage cover.



Slide out the dust cover. **CAUTION! DUST COVER EDGES ARE SHARP!**



Insert angled syringe tip into grease hole in bearing end cap. With the power on and using the manual control knob (if equipped), move the stage about 100 mm (4") while squeezing grease in from the syringe. Don't drive the carriage close to the ends of the stage where the risk is greater of squishing the syringe or your fingers. Repeat with the other three end caps.

Reinstall dust cover



Slide dust cover into carriage, above angled sliding pads but below thin channel near the top. Position the dust cover so it's about even at both ends

Install one carriage end ramp and slide the top sheet in the thin channel near the top.



Attach the other carriage end ramp.



Position the dust cover so it comes close to the clamp holes at each end.



Loosely attach the clamps at each end. Run the stage back and forth once to position the dust cover. Gradually tighten the clamp screws, alternating between the two at each clamp. If part of the dust cover isn't seated properly, loosen the nearest clamp and re-tighten.

NMS23 Brake Cover Removal

The power-off brake is intended to operate with the attached brake covers. If form factor is an issue, the brake covers may be carefully removed as they protrude by up to 0.8 mm from the housing. Gently slide a screwdriver into the slot, and push the cover away from the shaft until it clears the edge of the opening.

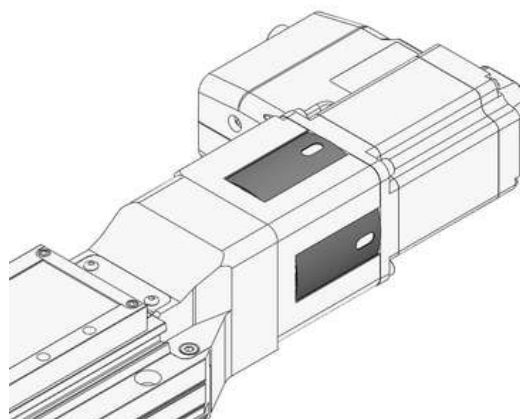

Trajectory Control and Behaviour

This section describes the behaviour of the axis trajectory when a movement command is issued.

Software Position Limits

The travel range of the axis is limited by the Minimum Position and Maximum Position settings. The factory settings for the axis are configured to match the physical travel range. If a customized range is desired, it can be changed by configuring the [limit.min \(T:106\)](#) and [limit.max \(T:44\)](#) settings to appropriate values. For the Current Position, query [pos \(T:60\)](#).

Minimum Position

When the Current Position is less than the Minimum Position value, the axis cannot move in the negative direction (towards the motor).

Maximum Position

When the Current Position is greater than the Maximum Position value, the axis cannot move in the positive direction (away from the motor).

Movement Speed

The movement speed of the axis depends on axis status and various speed settings. If the axis has not been initialized by the [home \(T:1\)](#) command or by moving towards the home end of the axis, movement speed will be constrained to fail-safe values. The home status of the axis can be determined by reading the [limit.home.triggered\(T:53:103\)](#) setting.

Movement speed of the axis is specified below:

[move vel \(T:22\)](#)

The axis will move at the specified speed regardless of home status.

Knob movement in Velocity Mode

The axis will move at the specified speed regardless of home status.

The speed is specified by the [knob.speedprofile \(T:112\)](#) and [knob.maxspeed \(T:111\)](#) settings.

Other movement commands - when the axis has not been homed

The axis will move at the slower of the [maxspeed \(T:42\)](#) and [limit.approach.maxspeed \(T:41\)](#) settings.

Other movement commands - when the axis has been homed

The axis will move at the speed specified by the [maxspeed \(T:42\)](#) setting.

Power-Off Brake Control

Described below are the recommended procedures for operating a brake-equipped device:

Dynamic Brake Engagement - For Position Holding After Faults

The power-off brake opens by default when the system is powered up. The brake will close if the device stalls, is displaced while stationary, the driver is disabled, or the power is interrupted. Repeated dynamic stopping may reduce the lifetime of the brake. We strongly recommend avoiding dynamic braking when possible.

Stationary Brake Engagement - For Position Holding

The power-off brake opens by default when the system is powered up. To change the brake state, use `brake.mode`.

The order of operations to set a retaining position should follow:

- Open the brake by setting `brake.mode` to 1.
- Allow 100 ms for the brake to open.
- Move the positioner.
- Close the brake by setting `brake.mode` to 0.
- Allow 100 ms for the brake to close.

If accuracy is required, the [driver.current.hold](#) (T:39) should remain on to prevent slight shifts in the device position.

Stationary Brake Engagement - For Reducing Motor Heat

The power-off brake opens by default when the system is powered up. To change the brake state, use `brake.mode`. To reduce heat generated in the motor, use the driver disable command in between moves.

The order of operations to maintain a vertical position, and disabling the driver to reduce heat, should follow:

- Set the hold current to the appropriate value based on load (see [defaults](#) on website).
- Move the positioner to the intended location.
- Send the [driver.disable](#) command. The brake will automatically close.
- When ready to move again, send the [driver.enable](#) command. The brake will open.
- Move the positioner as normal

Turning off the hold current will cause a small displacement of the positioner.

Manual Device Movement

Manual Device movement requires disabling the encoder displacement detection to prevent engagement of the power-off brake. The order of operations for manual movement should follow:

- Remove any load from the positioner.
- Disable closed-loop control by setting `clloop.enable` to 0 .
- Set the hold current to 0.
- Move the positioner manually by hand. For screw driven linear devices, turning the lead screw can assist in achieving smaller increments during manual movement.

Warranty and Repair

For Zaber's policies on warranty and repair, please refer to the [Ordering Policies](#).

Standard products

Standard products are any part numbers that do not contain the suffix ENG followed by a 4 digit number. Most, but not all, standard products are listed for sale on our website. All standard Zaber products are backed by a one-month satisfaction guarantee. If you are not satisfied with your purchase, we will refund your payment minus any shipping charges. Goods must be in brand new saleable condition with no marks. Zaber products are guaranteed for one year. During this period Zaber will repair any products with faults due to manufacturing defects, free of charge.

Custom products

Custom products are any part numbers containing the suffix ENG followed by a 4 digit number. Each of these products has been designed for a custom application for a particular customer. Custom products are guaranteed for one year, unless explicitly stated otherwise. During this period Zaber will repair any products with faults due to manufacturing defects, free of charge.

How to return products

Customers with devices in need of return or repair should contact Zaber to obtain an RMA form which must be filled out and sent back to us to receive an RMA number. The RMA form contains instructions for packing and returning the device. The specified RMA number must be included on the shipment to ensure timely processing.

Email Updates

If you would like to receive our periodic email newsletter including product updates and promotions.

Contact Information

Contact Zaber Technologies Inc by any of the following methods:

Phone	1-604-569-3780 (direct) 1-888-276-8033 (toll free in North America)
Fax	1-604-648-8033
Mail	#2 - 605 West Kent Ave. N., Vancouver, British Columbia, Canada, V6P 6T7
Web	www.zaber.com
Email	Please visit our website for up to date email contact information.

The original instructions for this product are available at <https://www.zaber.com/manuals/LRT-EC>.

Appendix A: Default Settings

Please see [the Zaber Support Page](#) for default settings for this device.

Product Drawings

ZABER

LRT-EC Motorized Stage
dimensions in mm

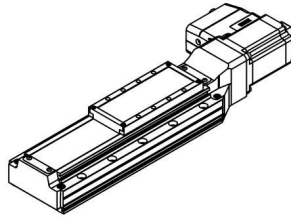

Model Number*	Travel	A	B
LRT0100xL-ECT3A	100	417.8	245
LRT0250xL-ECT3A	250	567.8	395
LRT0500xL-ECT3A	500	817.8	645
LRT0750xL-ECT3A	750	1067.8	895
LRT1000xL-ECT3A	1000	1317.8	1145
LRT1500xL-ECT3A	1500	1817.8	1645

*See product page for complete list of available models at www.zaber.com

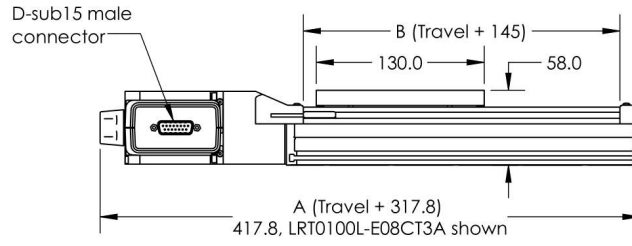
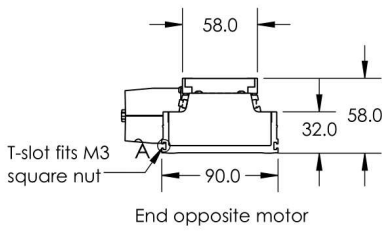
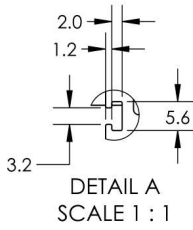
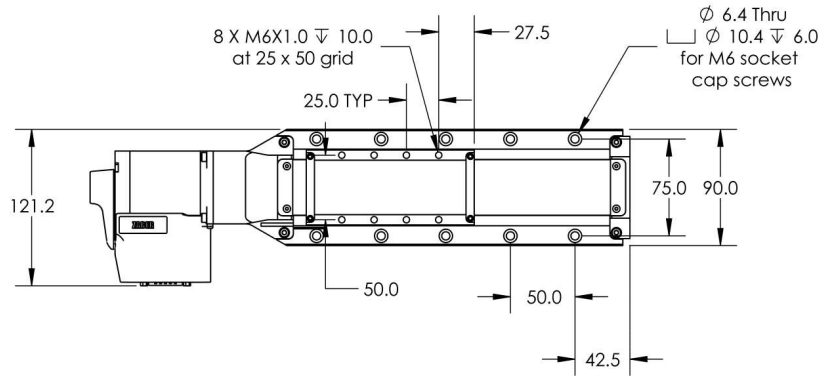

ZABER

LRT-BE08CT10A

dimensions in mm

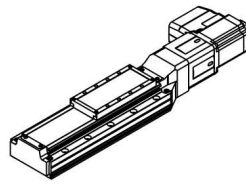

Model Number*	Travel	A	B
LRT0100-BE08CT10A	100.0	473.8	245.0
LRT0250-BE08CT10A	250.0	623.8	395.0
LRT0500-BE08CT10A	500.0	873.8	645.0
LRT0750-BE08CT10A	750.0	1123.8	895.0
LRT1000-BE08CT10A	1000.0	1373.8	1145.0
LRT1500-BE08CT10A	1500.0	1873.8	1645.0

*See product page for complete list of available models at www.zaber.com

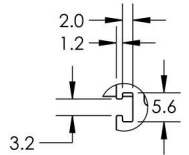

DETAIL A
SCALE 1 : 1

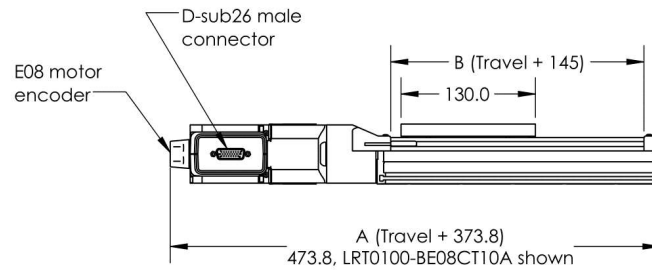
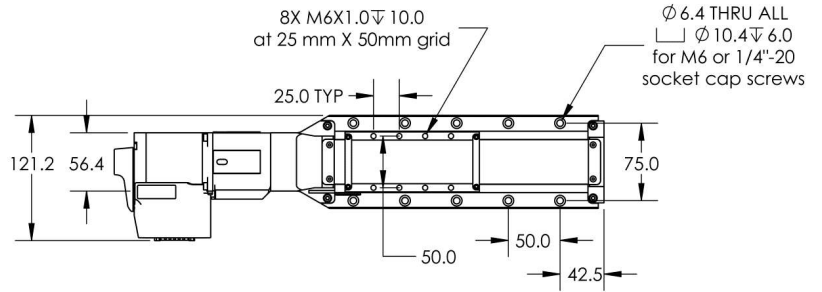
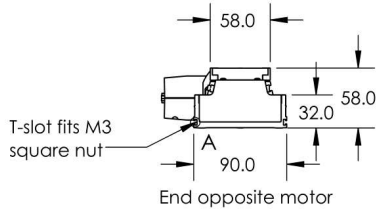

DWG 4200 R01

Specifications

Specification	Value	Alternate Unit
Built-in Controller	No	
Recommended Controller	X-MCC (48 V) Recommended	
AutoDetect	Yes	
Encoder Resolution	400 CPR	1600 states/rev
Encoder Type	Rotary quadrature encoder	
Maximum Centered Load	2940 N	659.3 lb
Maximum Moment (Pitch)	70 N·m	51.7 ft·lb
Maximum Moment (Roll)	120 N·m	88.6 ft·lb
Maximum Moment (Yaw)	70 N·m	51.7 ft·lb
Vertical Runout	< 10 µm	< 0.000394"
Horizontal Runout	< 50 µm	< 0.001968"
Pitch	0.015°	0.262 mrad
Roll	0.02°	0.349 mrad
Yaw	0.03°	0.523 mrad
Stiffness in Pitch	1400 N·m/°	12 µrad/N·m
Stiffness in Roll	700 N·m/°	25 µrad/N·m
Stiffness in Yaw	1200 N·m/°	15 µrad/N·m
Motor Steps Per Rev	200	

Specification	Value	Alternate Unit
Motor Type	Stepper (2 phase)	
Motor Rated Current	3000 mA/phase	
Motor Winding Resistance	0.53 ohms/phase	
Inductance	2 mH/phase	
Motor Connection	D-sub 15	
Default Resolution	1/64 of a step	
Guide Type	Recirculating Ball Linear Guide	
Limit or Home Sensing	Magnetic home sensor	
Axes of Motion	1	
Operating Temperature Range	0 to 50 °C	
CE Compliant	Yes	
Vacuum Compatible	No	

Comparison

Part Number	Microstep Size (Default Resolution)	Travel Range	Accuracy (unidirectional)	Repeatability
LRT0100AL-E08CT3A	0.124023438 µm	100 mm (3.937")	25 µm (0.000984")	< 4 µm (< 0.000157")
LRT0100BL-E08CT3A	0.49609375 µm	100 mm (3.937")	25 µm (0.000984")	< 4 µm (< 0.000157")
LRT0100BL-BE08CT10A	0.49609375 µm	100 mm (3.937")	25 µm (0.000984")	< 4 µm (< 0.000157")
LRT0100DL-E08CT3A	1.984375 µm	100 mm (3.937")	25 µm (0.000984")	< 8 µm (< 0.000315")
LRT0100DL-BE08CT10A	1.984375 µm	100 mm (3.937")	25 µm (0.000984")	< 8 µm (< 0.000315")
LRT0100HL-E08CT3A	0.390625 µm	100 mm (3.937")	45 µm (0.001772")	< 4 µm (< 0.000157")
LRT0100HL-BE08CT10A	0.390625 µm	100 mm (3.937")	45 µm (0.001772")	< 4 µm (< 0.000157")
LRT0250AL-E08CT3A	0.124023438 µm	250 mm (9.843")	63 µm (0.002480")	< 4 µm (< 0.000157")
LRT0250BL-E08CT3A	0.49609375 µm	250 mm (9.843")	63 µm (0.002480")	< 4 µm (< 0.000157")
LRT0250BL-BE08CT10A	0.49609375 µm	250 mm (9.843")	63 µm (0.002480")	< 4 µm (< 0.000157")
LRT0250DL-E08CT3A	1.984375 µm	250 mm (9.843")	63 µm (0.002480")	< 8 µm (< 0.000315")
LRT0250DL-BE08CT10A	1.984375 µm	250 mm (9.843")	63 µm (0.002480")	< 8 µm (< 0.000315")
LRT0250HL-E08CT3A	0.390625 µm	250 mm (9.843")	113 µm (0.004449")	< 4 µm (< 0.000157")
LRT0250HL-BE08CT10A	0.390625 µm	250 mm (9.843")	113 µm (0.004449")	< 4 µm (< 0.000157")
LRT0500AL-E08CT3A	0.124023438 µm	500 mm (19.685")	125 µm (0.004921")	< 4 µm (< 0.000157")
LRT0500BL-E08CT3A	0.49609375 µm	500 mm (19.685")	125 µm (0.004921")	< 4 µm (< 0.000157")
LRT0500BL-BE08CT10A	0.49609375 µm	500 mm (19.685")	125 µm (0.004921")	< 4 µm (< 0.000157")
LRT0500DL-E08CT3A	1.984375 µm	500 mm (19.685")	125 µm (0.004921")	< 8 µm (< 0.000315")
LRT0500DL-BE08CT10A	1.984375 µm	500 mm (19.685")	125 µm (0.004921")	< 8 µm (< 0.000315")
LRT0500HL-E08CT3A	0.390625 µm	500 mm (19.685")	225 µm (0.008858")	< 4 µm (< 0.000157")
LRT0500HL-BE08CT10A	0.390625 µm	500 mm (19.685")	225 µm (0.008858")	< 4 µm (< 0.000157")
LRT0750AL-E08CT3A	0.124023438 µm	750 mm (29.528")	188 µm (0.007402")	< 4 µm (< 0.000157")
LRT0750BL-E08CT3A	0.49609375 µm	750 mm (29.528")	188 µm (0.007402")	< 4 µm (< 0.000157")
LRT0750BL-BE08CT10A	0.49609375 µm	750 mm (29.528")	188 µm (0.007402")	< 4 µm (< 0.000157")
LRT0750DL-E08CT3A	1.984375 µm	750 mm (29.528")	188 µm (0.007402")	< 8 µm (< 0.000315")
LRT0750DL-BE08CT10A	1.984375 µm	750 mm (29.528")	188 µm (0.007402")	< 8 µm (< 0.000315")
LRT0750HL-E08CT3A	0.390625 µm	750 mm (29.528")	338 µm (0.013307")	< 4 µm (< 0.000157")

Part Number	Microstep Size (Default Resolution)	Travel Range	Accuracy (unidirectional)	Repeatability
LRT0750HL-BE08CT10A	0.390625 µm	750 mm (29.528")	338 µm (0.013307")	< 4 µm (< 0.000157")
LRT1000AL-E08CT3A	0.124023438 µm	1000 mm (39.370")	250 µm (0.009842")	< 4 µm (< 0.000157")
LRT1000BL-E08CT3A	0.49609375 µm	1000 mm (39.370")	250 µm (0.009842")	< 4 µm (< 0.000157")
LRT1000BL-BE08CT10A	0.49609375 µm	1000 mm (39.370")	250 µm (0.009842")	< 4 µm (< 0.000157")
LRT1000DL-E08CT3A	1.984375 µm	1000 mm (39.370")	250 µm (0.009842")	< 8 µm (< 0.000315")
LRT1000DL-BE08CT10A	1.984375 µm	1000 mm (39.370")	250 µm (0.009842")	< 8 µm (< 0.000315")
LRT1000HL-E08CT3A	0.390625 µm	1000 mm (39.370")	450 µm (0.017716")	< 4 µm (< 0.000157")
LRT1000HL-BE08CT10A	0.390625 µm	1000 mm (39.370")	450 µm (0.017716")	< 4 µm (< 0.000157")
LRT1500AL-E08CT3A	0.124023438 µm	1500 mm (59.055")	375 µm (0.014764")	< 4 µm (< 0.000157")
LRT1500BL-E08CT3A	0.49609375 µm	1500 mm (59.055")	375 µm (0.014764")	< 4 µm (< 0.000157")
LRT1500BL-BE08CT10A	0.49609375 µm	1500 mm (59.055")	375 µm (0.014764")	< 4 µm (< 0.000157")
LRT1500DL-E08CT3A	1.984375 µm	1500 mm (59.055")	375 µm (0.014764")	< 8 µm (< 0.000315")
LRT1500DL-BE08CT10A	1.984375 µm	1500 mm (59.055")	375 µm (0.014764")	< 8 µm (< 0.000315")

Part Number	Backlash	Maximum Speed	Minimum Speed	Speed Resolution
LRT0100AL-E08CT3A	< 12 µm (< 0.000472")	45 mm/s (1.772"/s)	0.000076 mm/s (0.000003"/s)	0.000076 mm/s (0.000003"/s)
LRT0100BL-E08CT3A	< 45 µm (< 0.001772")	175 mm/s (6.890"/s)	0.000303 mm/s (0.000012"/s)	0.000303 mm/s (0.000012"/s)
LRT0100BL-BE08CT10A	< 45 µm (< 0.001772")	175 mm/s (6.890"/s)	0.000303 mm/s (0.000012"/s)	0.000303 mm/s (0.000012"/s)
LRT0100DL-E08CT3A	< 75 µm (< 0.002953")	700 mm/s (27.559"/s)	0.001212 mm/s (0.000048"/s)	0.001212 mm/s (0.000048"/s)
LRT0100DL-BE08CT10A	< 75 µm (< 0.002953")	700 mm/s (27.559"/s)	0.001212 mm/s (0.000048"/s)	0.001212 mm/s (0.000048"/s)
LRT0100HL-E08CT3A	< 25 µm (< 0.000984")	240 mm/s (9.449"/s)	0.000239 mm/s (0.000009"/s)	0.000239 mm/s (0.000009"/s)
LRT0100HL-BE08CT10A	< 25 µm (< 0.000984")	240 mm/s (9.449"/s)	0.000239 mm/s (0.000009"/s)	0.000239 mm/s (0.000009"/s)
LRT0250AL-E08CT3A	< 12 µm (< 0.000472")	45 mm/s (1.772"/s)	0.000076 mm/s (0.000003"/s)	0.000076 mm/s (0.000003"/s)
LRT0250BL-E08CT3A	< 45 µm (< 0.001772")	175 mm/s (6.890"/s)	0.000303 mm/s (0.000012"/s)	0.000303 mm/s (0.000012"/s)
LRT0250BL-BE08CT10A	< 45 µm (< 0.001772")	175 mm/s (6.890"/s)	0.000303 mm/s (0.000012"/s)	0.000303 mm/s (0.000012"/s)
LRT0250DL-E08CT3A	< 75 µm (< 0.002953")	700 mm/s (27.559"/s)	0.001212 mm/s (0.000048"/s)	0.001212 mm/s (0.000048"/s)
LRT0250DL-BE08CT10A	< 75 µm (< 0.002953")	700 mm/s (27.559"/s)	0.001212 mm/s (0.000048"/s)	0.001212 mm/s (0.000048"/s)
LRT0250HL-E08CT3A	< 25 µm (< 0.000984")	240 mm/s (9.449"/s)	0.000239 mm/s (0.000009"/s)	0.000239 mm/s (0.000009"/s)
LRT0250HL-BE08CT10A	< 25 µm (< 0.000984")	240 mm/s (9.449"/s)	0.000239 mm/s (0.000009"/s)	0.000239 mm/s (0.000009"/s)
LRT0500AL-E08CT3A	< 12 µm (< 0.000472")	45 mm/s (1.772"/s)	0.000076 mm/s (0.000003"/s)	0.000076 mm/s (0.000003"/s)
LRT0500BL-E08CT3A	< 45 µm (< 0.001772")	175 mm/s (6.890"/s)	0.000303 mm/s (0.000012"/s)	0.000303 mm/s (0.000012"/s)

Part Number	Backlash	Maximum Speed	Minimum Speed	Speed Resolution
LRT0500BL-BE08CT10A	< 45 µm (< 0.001772")	175 mm/s (6.890"/s)	0.000303 mm/s (0.000012"/s)	0.000303 mm/s (0.000012"/s)
LRT0500DL-E08CT3A	< 75 µm (< 0.002953")	700 mm/s (27.559"/s)	0.001212 mm/s (0.000048"/s)	0.001212 mm/s (0.000048"/s)
LRT0500DL-BE08CT10A	< 75 µm (< 0.002953")	700 mm/s (27.559"/s)	0.001212 mm/s (0.000048"/s)	0.001212 mm/s (0.000048"/s)
LRT0500HL-E08CT3A	< 25 µm (< 0.000984")	240 mm/s (9.449"/s)	0.000239 mm/s (0.000009"/s)	0.000239 mm/s (0.000009"/s)
LRT0500HL-BE08CT10A	< 25 µm (< 0.000984")	240 mm/s (9.449"/s)	0.000239 mm/s (0.000009"/s)	0.000239 mm/s (0.000009"/s)
LRT0750AL-E08CT3A	< 12 µm (< 0.000472")	45 mm/s (1.772"/s)	0.000076 mm/s (0.000003"/s)	0.000076 mm/s (0.000003"/s)
LRT0750BL-E08CT3A	< 45 µm (< 0.001772")	175 mm/s (6.890"/s)	0.000303 mm/s (0.000012"/s)	0.000303 mm/s (0.000012"/s)
LRT0750BL-BE08CT10A	< 45 µm (< 0.001772")	175 mm/s (6.890"/s)	0.000303 mm/s (0.000012"/s)	0.000303 mm/s (0.000012"/s)
LRT0750DL-E08CT3A	< 75 µm (< 0.002953")	700 mm/s (27.559"/s)	0.001212 mm/s (0.000048"/s)	0.001212 mm/s (0.000048"/s)
LRT0750DL-BE08CT10A	< 75 µm (< 0.002953")	700 mm/s (27.559"/s)	0.001212 mm/s (0.000048"/s)	0.001212 mm/s (0.000048"/s)
LRT0750HL-E08CT3A	< 25 µm (< 0.000984")	150 mm/s (5.905"/s)	0.000239 mm/s (0.000009"/s)	0.000239 mm/s (0.000009"/s)
LRT0750HL-BE08CT10A	< 25 µm (< 0.000984")	150 mm/s (5.905"/s)	0.000239 mm/s (0.000009"/s)	0.000239 mm/s (0.000009"/s)
LRT1000AL-E08CT3A	< 12 µm (< 0.000472")	28 mm/s (1.102"/s)	0.000076 mm/s (0.000003"/s)	0.000076 mm/s (0.000003"/s)
LRT1000BL-E08CT3A	< 45 µm (< 0.001772")	120 mm/s (4.724"/s)	0.000303 mm/s (0.000012"/s)	0.000303 mm/s (0.000012"/s)
LRT1000BL-BE08CT10A	< 45 µm (< 0.001772")	120 mm/s (4.724"/s)	0.000303 mm/s (0.000012"/s)	0.000303 mm/s (0.000012"/s)
LRT1000DL-E08CT3A	< 75 µm (< 0.002953")	500 mm/s (19.685"/s)	0.001212 mm/s (0.000048"/s)	0.001212 mm/s (0.000048"/s)
LRT1000DL-BE08CT10A	< 75 µm (< 0.002953")	500 mm/s (19.685"/s)	0.001212 mm/s (0.000048"/s)	0.001212 mm/s (0.000048"/s)
LRT1000HL-E08CT3A	< 25 µm (< 0.000984")	95 mm/s (3.740"/s)	0.000239 mm/s (0.000009"/s)	0.000239 mm/s (0.000009"/s)
LRT1000HL-BE08CT10A	< 25 µm (< 0.000984")	95 mm/s (3.740"/s)	0.000239 mm/s (0.000009"/s)	0.000239 mm/s (0.000009"/s)
LRT1500AL-E08CT3A	< 12 µm (< 0.000472")	13 mm/s (0.512"/s)	0.000076 mm/s (0.000003"/s)	0.000076 mm/s (0.000003"/s)
LRT1500BL-E08CT3A	< 45 µm (< 0.001772")	55 mm/s (2.165"/s)	0.000303 mm/s (0.000012"/s)	0.000303 mm/s (0.000012"/s)
LRT1500BL-BE08CT10A	< 45 µm (< 0.001772")	55 mm/s (2.165"/s)	0.000303 mm/s (0.000012"/s)	0.000303 mm/s (0.000012"/s)
LRT1500DL-E08CT3A	< 75 µm (< 0.002953")	225 mm/s (8.858"/s)	0.001212 mm/s (0.000048"/s)	0.001212 mm/s (0.000048"/s)
LRT1500DL-BE08CT10A	< 75 µm (< 0.002953")	225 mm/s (8.858"/s)	0.001212 mm/s (0.000048"/s)	0.001212 mm/s (0.000048"/s)

Part Number	Peak Thrust	Back-driving Force*	Maximum Continuous Thrust	Linear Motion Per Motor Rev
LRT0100AL-E08CT3A	1200 N (269.1 lb)	Non-back-driving	1200 N (269.1 lb)	1.5875 mm (0.062")
LRT0100BL-E08CT3A	600 N (134.6 lb)	420 N (94.2 lb) (± 30%)	600 N (134.6 lb)	6.35 mm (0.250")
LRT0100BL-BE08CT10A	600 N (134.6 lb)	420 N (94.2 lb) (± 30%)	600 N (134.6 lb)	6.35 mm (0.250")
LRT0100DL-E08CT3A	200 N (44.9 lb)	40 N (9.0 lb) (± 30%)	180 N (40.4 lb)	25.4 mm (1.000")
LRT0100DL-BE08CT10A	200 N (44.9 lb)	40 N (9.0 lb) (± 30%)	180 N (40.4 lb)	25.4 mm (1.000")
LRT0100HL-E08CT3A	1200 N (269.1 lb)	157 N (35.2 lb) (± 30%)	1200 N (269.1 lb)	5 mm (0.197")
LRT0100HL-BE08CT10A	1200 N (269.1 lb)	157 N (35.2 lb) (± 30%)	1200 N (269.1 lb)	5 mm (0.197")
LRT0250AL-E08CT3A	1200 N (269.1 lb)	Non-back-driving	1200 N (269.1 lb)	1.5875 mm (0.062")
LRT0250BL-E08CT3A	600 N (134.6 lb)	420 N (94.2 lb) (± 30%)	600 N (134.6 lb)	6.35 mm (0.250")
LRT0250BL-BE08CT10A	600 N (134.6 lb)	420 N (94.2 lb) (± 30%)	600 N (134.6 lb)	6.35 mm (0.250")
LRT0250DL-E08CT3A	200 N (44.9 lb)	40 N (9.0 lb) (± 30%)	180 N (40.4 lb)	25.4 mm (1.000")
LRT0250DL-BE08CT10A	200 N (44.9 lb)	40 N (9.0 lb) (± 30%)	180 N (40.4 lb)	25.4 mm (1.000")
LRT0250HL-E08CT3A	1200 N (269.1 lb)	157 N (35.2 lb) (± 30%)	1200 N (269.1 lb)	5 mm (0.197")
LRT0250HL-BE08CT10A	1200 N (269.1 lb)	157 N (35.2 lb) (± 30%)	1200 N (269.1 lb)	5 mm (0.197")
LRT0500AL-E08CT3A	1200 N (269.1 lb)	Non-back-driving	1200 N (269.1 lb)	1.5875 mm (0.062")
LRT0500BL-E08CT3A	600 N (134.6 lb)	420 N (94.2 lb) (± 30%)	600 N (134.6 lb)	6.35 mm (0.250")
LRT0500BL-BE08CT10A	600 N (134.6 lb)	420 N (94.2 lb) (± 30%)	600 N (134.6 lb)	6.35 mm (0.250")
LRT0500DL-E08CT3A	200 N (44.9 lb)	40 N (9.0 lb) (± 30%)	180 N (40.4 lb)	25.4 mm (1.000")
LRT0500DL-BE08CT10A	200 N (44.9 lb)	40 N (9.0 lb) (± 30%)	180 N (40.4 lb)	25.4 mm (1.000")
LRT0500HL-E08CT3A	1200 N (269.1 lb)	157 N (35.2 lb) (± 30%)	1200 N (269.1 lb)	5 mm (0.197")
LRT0500HL-BE08CT10A	1200 N (269.1 lb)	157 N (35.2 lb) (± 30%)	1200 N (269.1 lb)	5 mm (0.197")
LRT0750AL-E08CT3A	1200 N (269.1 lb)	Non-back-driving	1200 N (269.1 lb)	1.5875 mm (0.062")
LRT0750BL-E08CT3A	600 N (134.6 lb)	420 N (94.2 lb) (± 30%)	600 N (134.6 lb)	6.35 mm (0.250")
LRT0750BL-BE08CT10A	600 N (134.6 lb)	420 N (94.2 lb) (± 30%)	600 N (134.6 lb)	6.35 mm (0.250")
LRT0750DL-E08CT3A	200 N (44.9 lb)	40 N (9.0 lb) (± 30%)	180 N (40.4 lb)	25.4 mm (1.000")
LRT0750DL-BE08CT10A	200 N (44.9 lb)	40 N (9.0 lb) (± 30%)	180 N (40.4 lb)	25.4 mm (1.000")

Part Number	Peak Thrust	Back-driving Force*	Maximum Continuous Thrust	Linear Motion Per Motor Rev
LRT0750HL-E08CT3A	1200 N (269.1 lb)	157 N (35.2 lb) (± 30%)	1200 N (269.1 lb)	5 mm (0.197")
LRT0750HL-BE08CT10A	1200 N (269.1 lb)	157 N (35.2 lb) (± 30%)	1200 N (269.1 lb)	5 mm (0.197")
LRT1000AL-E08CT3A	1200 N (269.1 lb)	Non-back-driving	1200 N (269.1 lb)	1.5875 mm (0.062")
LRT1000BL-E08CT3A	600 N (134.6 lb)	420 N (94.2 lb) (± 30%)	600 N (134.6 lb)	6.35 mm (0.250")
LRT1000BL-BE08CT10A	600 N (134.6 lb)	420 N (94.2 lb) (± 30%)	600 N (134.6 lb)	6.35 mm (0.250")
LRT1000DL-E08CT3A	200 N (44.9 lb)	40 N (9.0 lb) (± 30%)	180 N (40.4 lb)	25.4 mm (1.000")
LRT1000DL-BE08CT10A	200 N (44.9 lb)	40 N (9.0 lb) (± 30%)	180 N (40.4 lb)	25.4 mm (1.000")
LRT1000HL-E08CT3A	1200 N (269.1 lb)	157 N (35.2 lb) (± 30%)	1200 N (269.1 lb)	5 mm (0.197")
LRT1000HL-BE08CT10A	1200 N (269.1 lb)	157 N (35.2 lb) (± 30%)	1200 N (269.1 lb)	5 mm (0.197")
LRT1500AL-E08CT3A	1200 N (269.1 lb)	Non-back-driving	1200 N (269.1 lb)	1.5875 mm (0.062")
LRT1500BL-E08CT3A	600 N (134.6 lb)	420 N (94.2 lb) (± 30%)	600 N (134.6 lb)	6.35 mm (0.250")
LRT1500BL-BE08CT10A	600 N (134.6 lb)	420 N (94.2 lb) (± 30%)	600 N (134.6 lb)	6.35 mm (0.250")
LRT1500DL-E08CT3A	200 N (44.9 lb)	40 N (9.0 lb) (± 30%)	180 N (40.4 lb)	25.4 mm (1.000")
LRT1500DL-BE08CT10A	200 N (44.9 lb)	40 N (9.0 lb) (± 30%)	180 N (40.4 lb)	25.4 mm (1.000")

Part Number	Mechanical Drive System	Maximum Axial Brake Force	Weight
LRT0100AL-E08CT3A	Precision lead screw		3.65 kg (8.047 lb)
LRT0100BL-E08CT3A	Precision lead screw		3.65 kg (8.047 lb)
LRT0100BL-BE08CT10A	Precision lead screw	600 N (134.9 lb)	4.276 kg (9.427 lb)
LRT0100DL-E08CT3A	Precision lead screw		3.65 kg (8.047 lb)
LRT0100DL-BE08CT10A	Precision lead screw	180 N (40.5 lb)	4.276 kg (9.427 lb)
LRT0100HL-E08CT3A	Precision ball screw		3.65 kg (8.047 lb)
LRT0100HL-BE08CT10A	Precision ball screw	1200 N (269.8 lb)	4.276 kg (9.427 lb)
LRT0250AL-E08CT3A	Precision lead screw		4.441 kg (9.791 lb)
LRT0250BL-E08CT3A	Precision lead screw		4.441 kg (9.791 lb)
LRT0250BL-BE08CT10A	Precision lead screw	600 N (134.9 lb)	5.067 kg (11.171 lb)
LRT0250DL-E08CT3A	Precision lead screw		4.441 kg (9.791 lb)
LRT0250DL-BE08CT10A	Precision lead screw	180 N (40.5 lb)	5.067 kg (11.171 lb)
LRT0250HL-E08CT3A	Precision ball screw		4.441 kg (9.791 lb)
LRT0250HL-BE08CT10A	Precision ball screw	1200 N (269.8 lb)	5.067 kg (11.171 lb)
LRT0500AL-E08CT3A	Precision lead screw		5.758 kg (12.694 lb)
LRT0500BL-E08CT3A	Precision lead screw		5.758 kg (12.694 lb)
LRT0500BL-BE08CT10A	Precision lead screw	600 N (134.9 lb)	6.384 kg (14.074 lb)
LRT0500DL-E08CT3A	Precision lead screw		5.758 kg (12.694 lb)

Part Number	Mechanical Drive System	Maximum Axial Brake Force	Weight
LRT0500DL-BE08CT10A	Precision lead screw	180 N (40.5 lb)	6.384 kg (14.074 lb)
LRT0500HL-E08CT3A	Precision ball screw		5.758 kg (12.694 lb)
LRT0500HL-BE08CT10A	Precision ball screw	1200 N (269.8 lb)	6.384 kg (14.074 lb)
LRT0750AL-E08CT3A	Precision lead screw		7.076 kg (15.600 lb)
LRT0750BL-E08CT3A	Precision lead screw		7.076 kg (15.600 lb)
LRT0750BL-BE08CT10A	Precision lead screw	600 N (134.9 lb)	7.702 kg (16.980 lb)
LRT0750DL-E08CT3A	Precision lead screw		7.076 kg (15.600 lb)
LRT0750DL-BE08CT10A	Precision lead screw	180 N (40.5 lb)	7.702 kg (16.980 lb)
LRT0750HL-E08CT3A	Precision ball screw		7.076 kg (15.600 lb)
LRT0750HL-BE08CT10A	Precision ball screw	1200 N (269.8 lb)	7.702 kg (16.980 lb)
LRT1000AL-E08CT3A	Precision lead screw		8.393 kg (18.503 lb)
LRT1000BL-E08CT3A	Precision lead screw		8.393 kg (18.503 lb)
LRT1000BL-BE08CT10A	Precision lead screw	600 N (134.9 lb)	9.019 kg (19.883 lb)
LRT1000DL-E08CT3A	Precision lead screw		8.393 kg (18.503 lb)
LRT1000DL-BE08CT10A	Precision lead screw	180 N (40.5 lb)	9.019 kg (19.883 lb)
LRT1000HL-E08CT3A	Precision ball screw		8.393 kg (18.503 lb)
LRT1000HL-BE08CT10A	Precision ball screw	1200 N (269.8 lb)	9.019 kg (19.883 lb)
LRT1500AL-E08CT3A	Precision lead screw		11.028 kg (24.313 lb)
LRT1500BL-E08CT3A	Precision lead screw		11.028 kg (24.313 lb)
LRT1500BL-BE08CT10A	Precision lead screw	600 N (134.9 lb)	11.654 kg (25.693 lb)
LRT1500DL-E08CT3A	Precision lead screw		11.028 kg (24.313 lb)
LRT1500DL-BE08CT10A	Precision lead screw	180 N (40.5 lb)	11.654 kg (25.693 lb)

Thrust Speed Performance

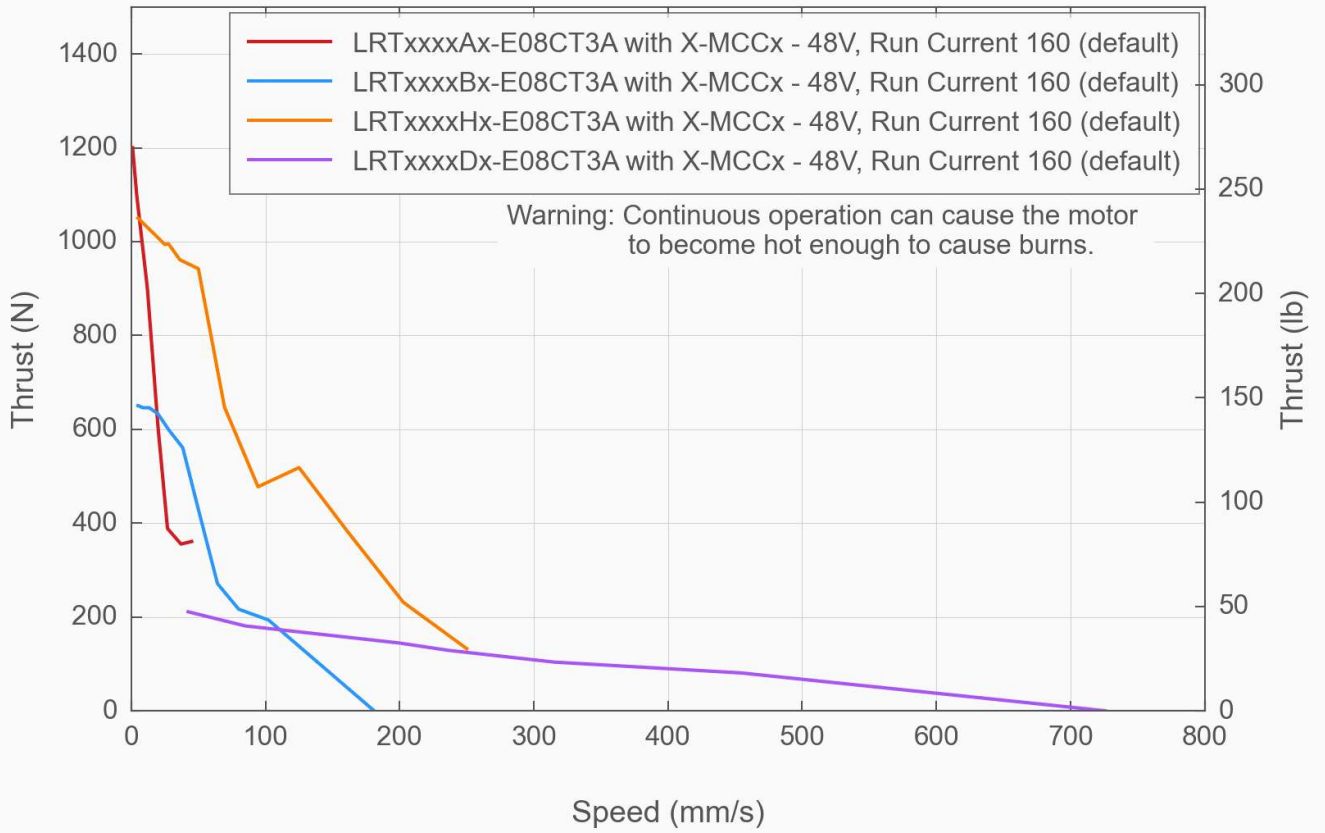

Thrust Speed Performance

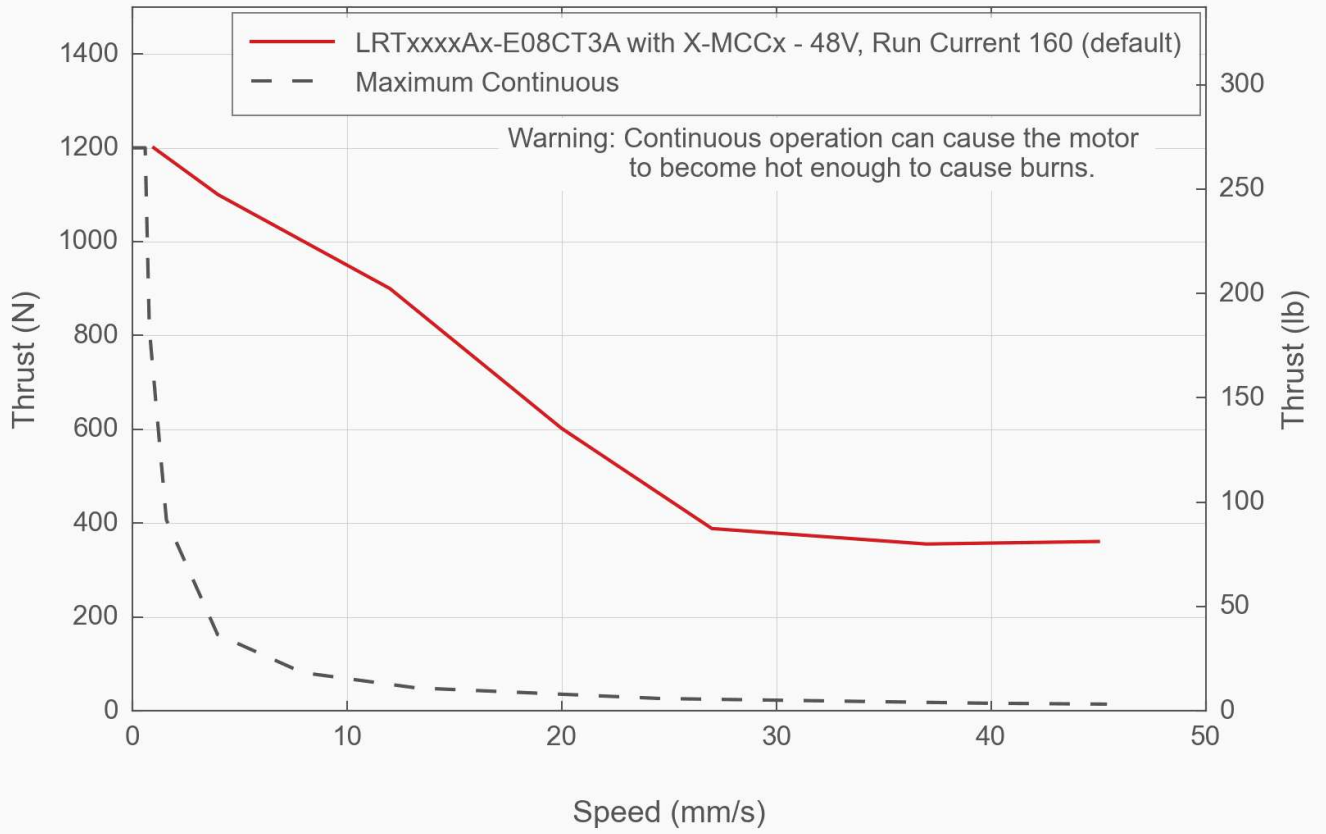

Thrust Speed Performance

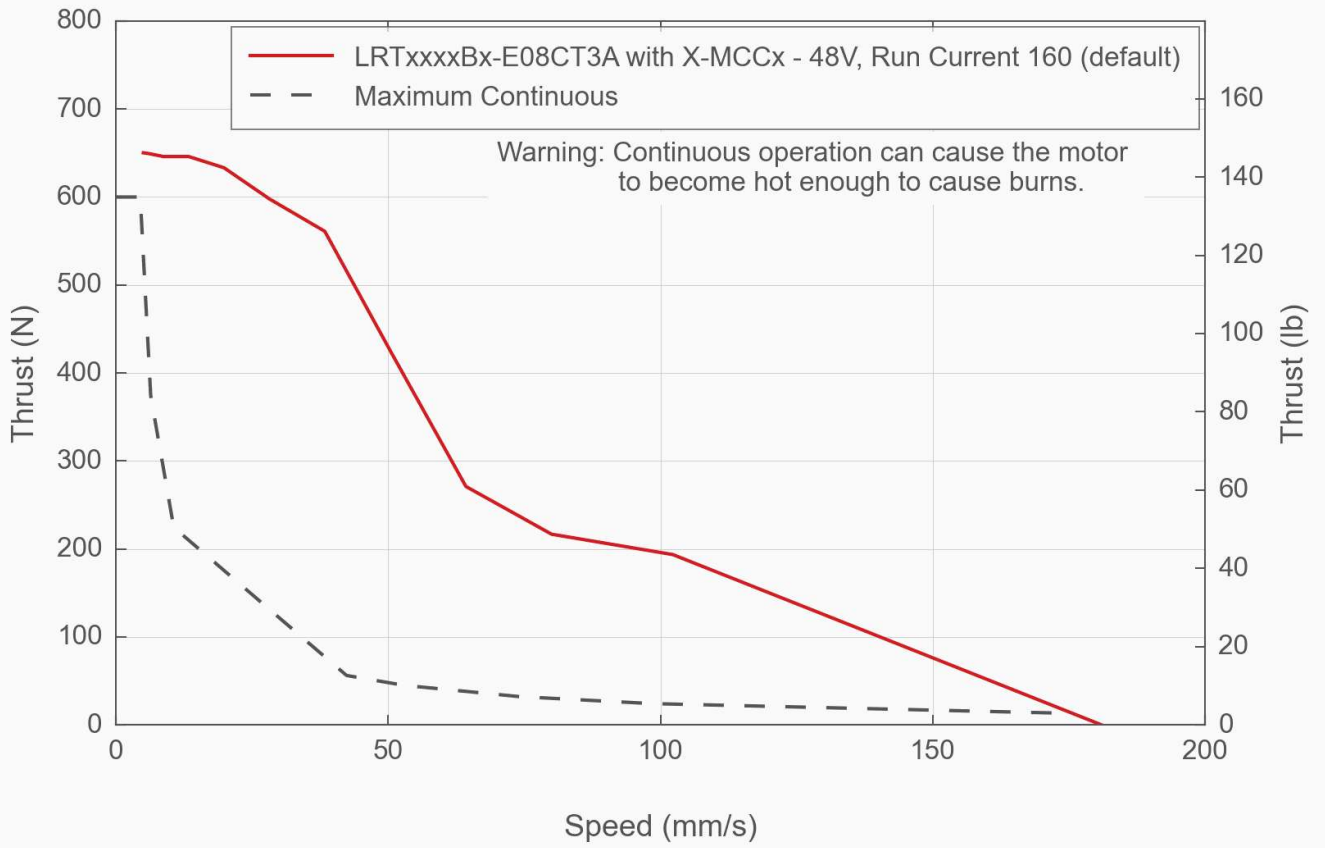

Thrust Speed Performance

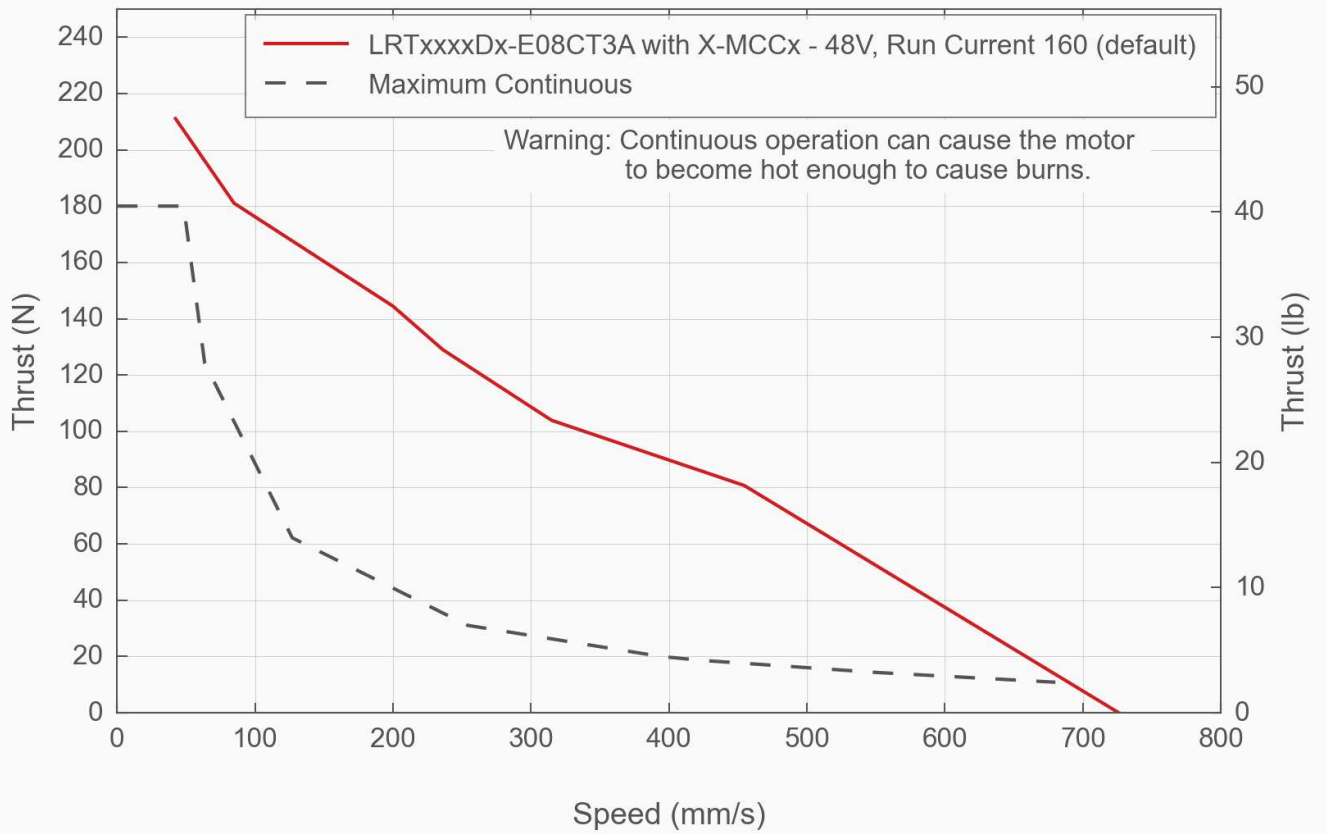

Thrust Speed Performance

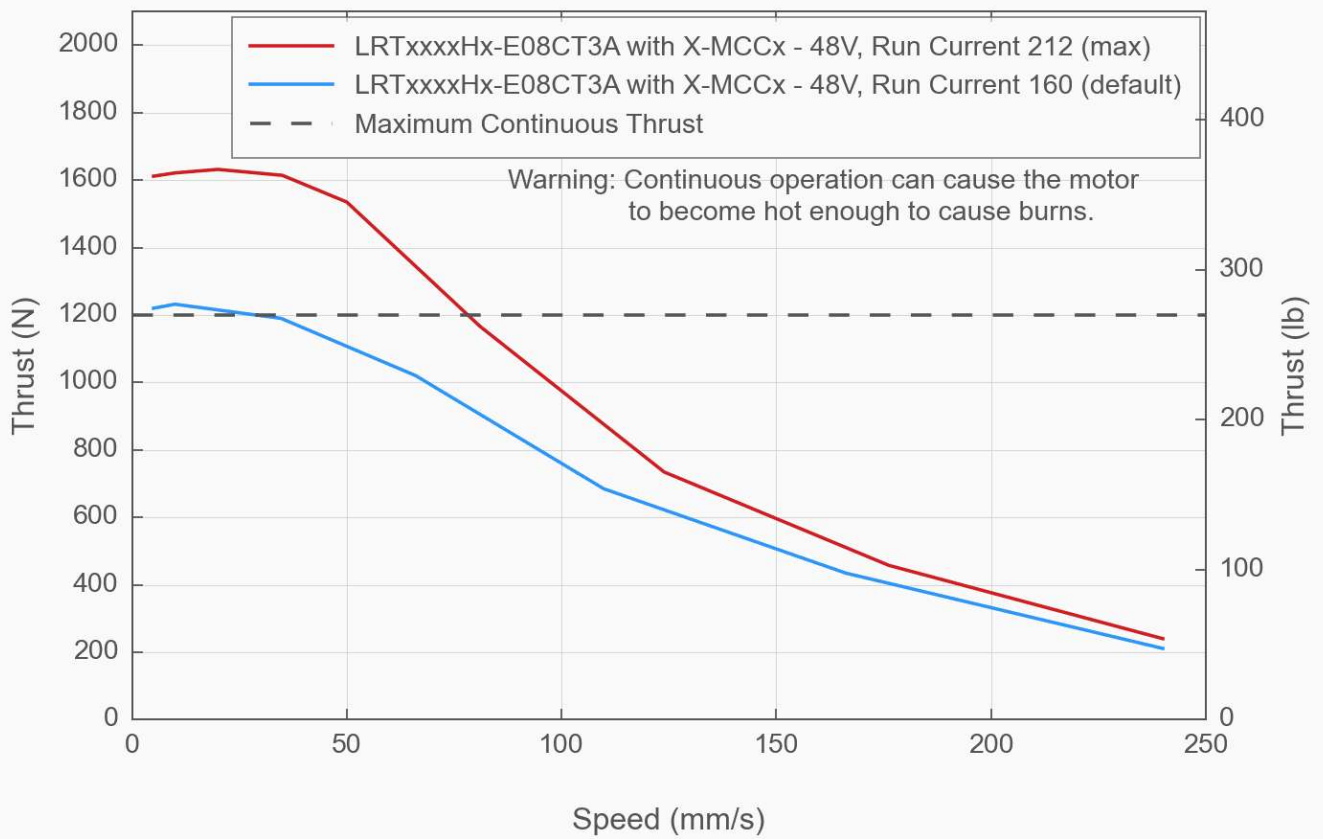

Typical LRT Bearing Lifetime

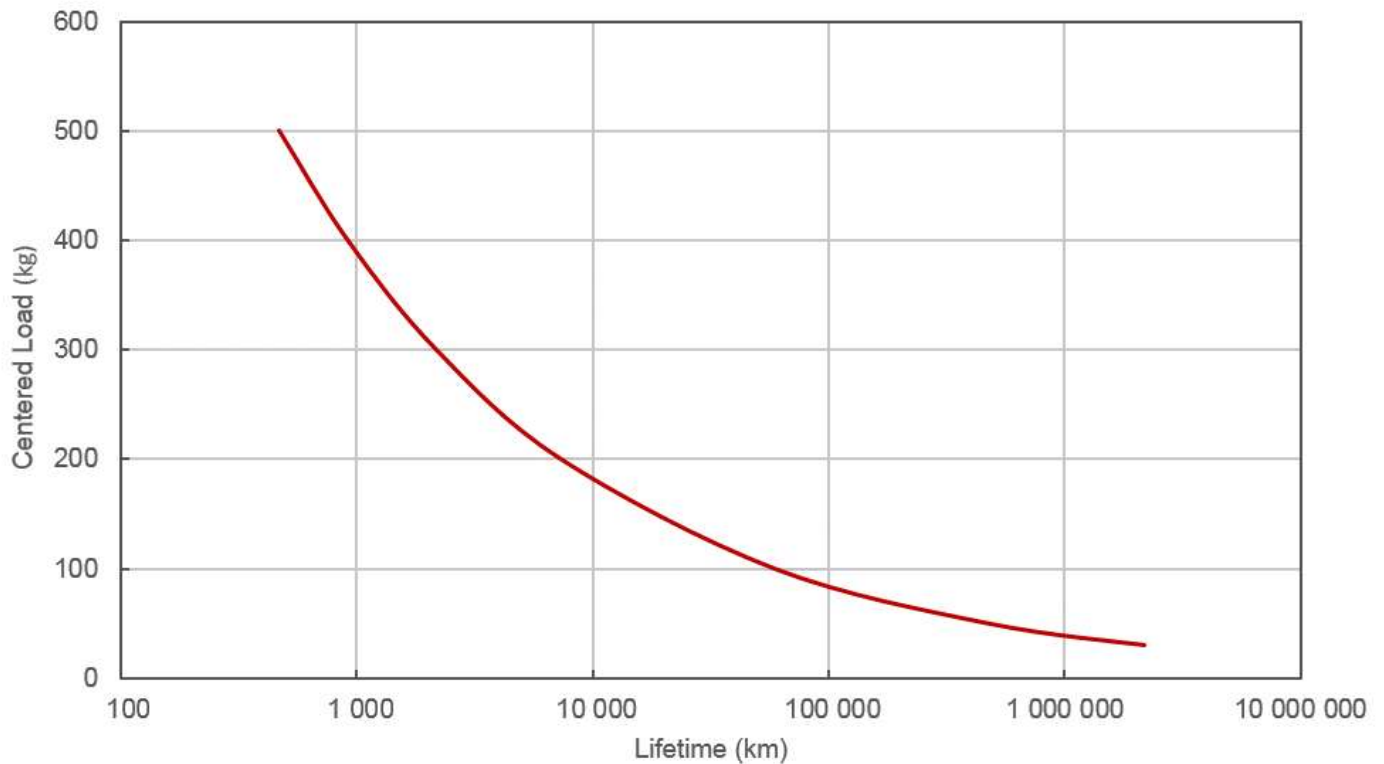

Product Change Notices

Click [here](#) to view the current product change notices and subscribe to future change notifications.