

X-BLQ-EC Series Datasheet



- 70 to 595 mm travel
- Up to 2.0 m/s speed, 55 N thrust, and 20 kg load capacity
- Encoder position feedback with slip/stall detection and automatic recovery
- Includes rigid cover
- Integrated recirculating ball bearing guide provides exceptional lifetime
- Built-in controller; daisy-chains with any other Zaber products

X-BLQ-EC Series Overview

Zaber's X-BLQ-EC Series products are computer controlled, belt-driven linear stages with integrated stepper motors and controllers. A built-in motor encoder allows closed-loop operation with slip/stall recovery features. A rigid non-contact cover prevents the ingress of small objects. They are stand-alone devices requiring only a standard 48 V power supply for operation.

An indexed knob provides convenient manual control for versatile operation even without a computer. These stages connect to the RS-232 port or USB port of any computer, and they can be daisy-chained with any other Zaber products. The daisy-chain also shares power, making it possible for multiple X-Series products to share a single power supply. Convenient locking, 4-pin, M8 connectors on the unit allow for secure connection between devices.

With travel lengths up to 595 mm, 20 μ m repeatability, and a maximum speed of 2.0 m/s, X-BLQ-EC stages are perfect for rapid positioning over large distances. Like all of Zaber's products, the X-BLQ-EC Series is designed to be 'plug and play' and very easy to set up and operate.

For more information visit: <https://www.zaber.com/products/linear-stages/X-BLQ-EC>

X-BLQ-EC Series Part Numbering & Options

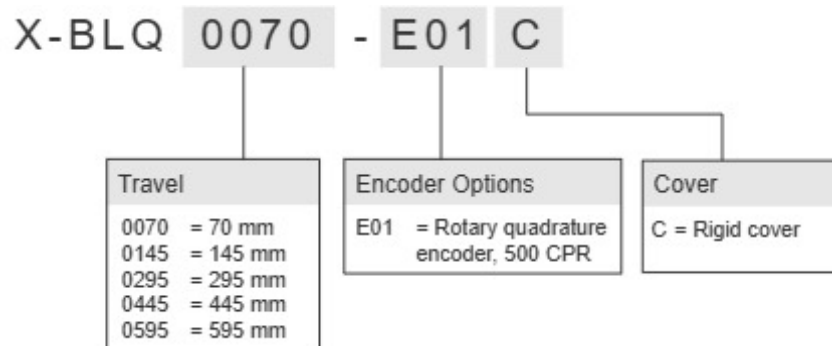

X-BLQ-EC Series Drawings

- [X-BLQ-EC.png \(Drawing for the X-BLQ-EC\)](#)

X-BLQ-EC Series Specifications

Microstep Size (Default Resolution)	4.21875 μm
Built-in Controller	Yes
Repeatability	< 20 μm (< 0.000787")
Backlash	< 75 μm (< 0.002953")
Minimum Speed	0.002576 mm/s (0.000101"/s)
Speed Resolution	0.002576 mm/s (0.000101"/s)
Encoder Resolution	500 CPR (2000 states/rev)
Encoder Type	Rotary quadrature encoder
Peak Thrust	55 N (12.3 lb)
Maximum Continuous Thrust	20 N (4.5 lb)
Communication Interface	RS-232
Communication Protocol	Zaber ASCII (Default), Zaber Binary
Data Cable Connection	Locking 4-pin M8
Maximum Centered Load	200 N (44.9 lb)
Maximum Moment (Pitch)	5 N-m (3.7 ft-lb)
Maximum Moment (Roll)	15 N-m (11.1 ft-lb)
Maximum Moment (Yaw)	5 N-m (3.7 ft-lb)
Vertical Runout	< 30 μm (< 0.001181")
Pitch	0.06° (1.047 mrad)
Roll	0.03° (0.523 mrad)
Yaw	0.03° (0.523 mrad)
Stiffness in Pitch	115 N-m/° (152 $\mu\text{rad/N-m}$)
Stiffness in Roll	145 N-m/° (120 $\mu\text{rad/N-m}$)
Stiffness in Yaw	110 N-m/° (159 $\mu\text{rad/N-m}$)
Power Supply	24-48 VDC
Maximum Current Draw	1800 mA
Linear Motion Per Motor Rev	54 mm (2.126")
Motor Steps Per Rev	200
Motor Type	Stepper (2 phase)
Motor Rated Current	2300 mA/phase
Inductance	2.2 mH/phase

Microstep Size (Default Resolution)	4.21875 μm
Default Resolution	1/64 of a step
Guide Type	Recirculating Ball Linear Guide
Mechanical Drive System	Synchronous belt
Limit or Home Sensing	Magnetic home sensor
Manual Control	Indexed knob with push switch
Axes of Motion	1
Mounting Interface	M6 threaded holes
Stage Parallelism	< 100 μm (< 0.003937")
Operating Temperature Range	0 to 50 °C
CE Compliant	Yes
Vacuum Compatible	No

Part Number	Travel Range	Accuracy (unidirectional)	Maximum Speed	Horizontal Runout
X-BLQ0070-E01C	70 mm (2.756")	200 μm (0.007874")	1100 mm/s (43.307"/s)	< 20 μm (< 0.000787")
X-BLQ0145-E01C	145 mm (5.709")	200 μm (0.007874")	1600 mm/s (62.992"/s)	< 30 μm (< 0.001181")
X-BLQ0295-E01C	295 mm (11.614")	300 μm (0.011811")	2000 mm/s (78.740"/s)	< 35 μm (< 0.001378")
X-BLQ0445-E01C	445 mm (17.520")	400 μm (0.015748")	2000 mm/s (78.740"/s)	< 40 μm (< 0.001575")
X-BLQ0595-E01C	595 mm (23.425")	500 μm (0.019685")	2000 mm/s (78.740"/s)	< 60 μm (< 0.002362")

Part Number	Weight
X-BLQ0070-E01C	1.86 kg (4.101 lb)
X-BLQ0145-E01C	2.05 kg (4.519 lb)
X-BLQ0295-E01C	2.4 kg (5.291 lb)
X-BLQ0445-E01C	2.8 kg (6.173 lb)
X-BLQ0595-E01C	3.12 kg (6.878 lb)

X-BLQ-EC Series Charts

Thrust Speed Performance

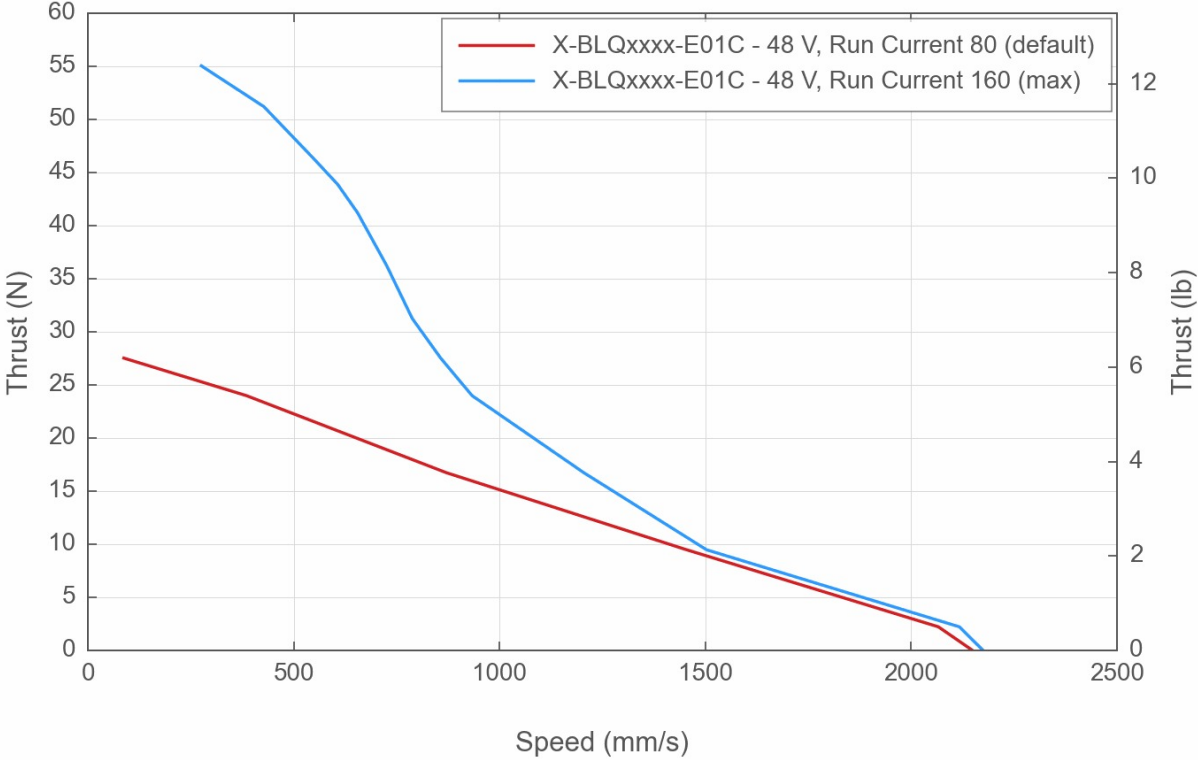

Horizontal Acceleration

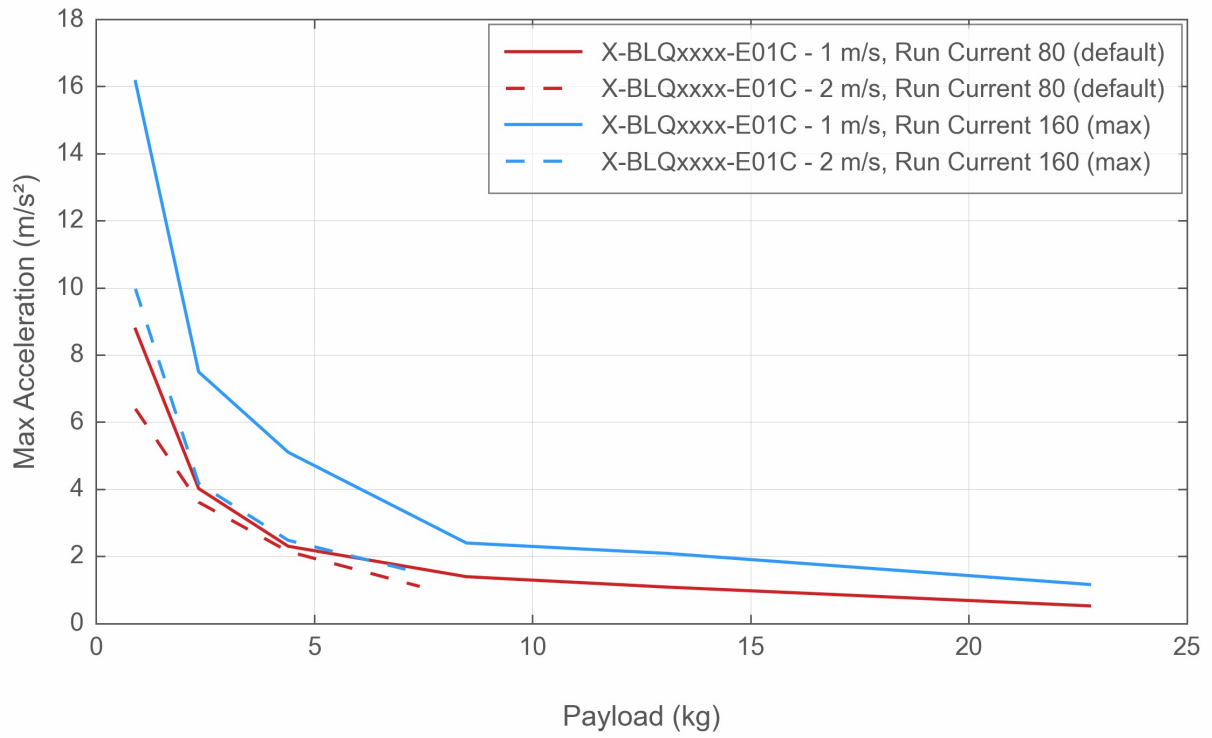

Typical Accuracy

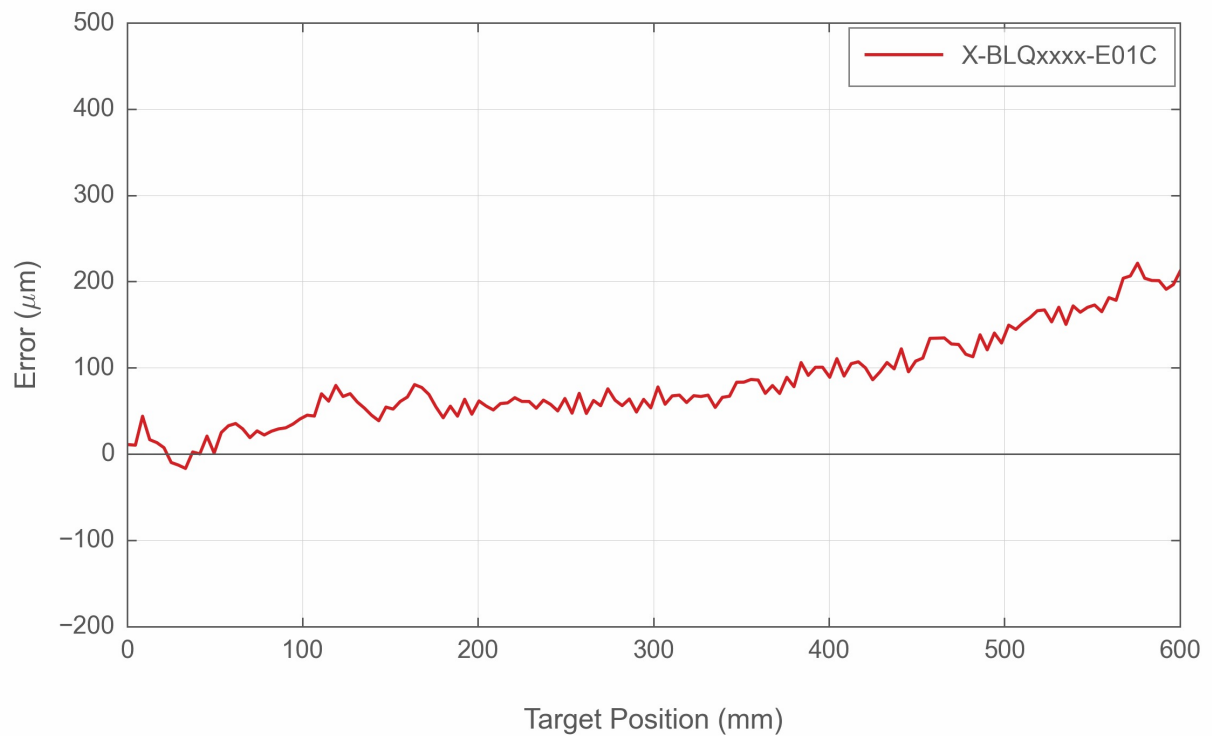

Contact

Email: contact@zaber.com

Phone (toll free Canada/USA): 1-888-276-8033

Phone (direct): 1-604-569-3780

Fax: 1-604-648-8033

Zaber Technologies Inc.

#2 - 605 West Kent Ave. N.

Vancouver, British Columbia

Canada, V6P 6T7

<https://www.zaber.com>