

X-BLQ0295-E01C Datasheet



- 70 to 595 mm travel
- Up to 2.0 m/s speed, 55 N thrust, and 20 kg load capacity
- Encoder position feedback with slip/stall detection and automatic recovery
- Includes rigid cover
- Integrated recirculating ball bearing guide provides exceptional lifetime
- Built-in controller; daisy-chains with any other Zaber products

X-BLQ-EC Series Overview

Zaber's X-BLQ-EC Series products are computer controlled, belt-driven linear stages with integrated stepper motors and controllers. A built-in motor encoder allows closed-loop operation with slip/stall recovery features. A rigid non-contact cover prevents the ingress of small objects. They are stand-alone devices requiring only a standard 48 V power supply for operation.

An indexed knob provides convenient manual control for versatile operation even without a computer. These stages connect to the RS-232 port or USB port of any computer, and they can be daisy-chained with any other Zaber products. The daisy-chain also shares power, making it possible for multiple X-Series products to share a single power supply. Convenient locking, 4-pin, M8 connectors on the unit allow for secure connection between devices.

With travel lengths up to 595 mm, 20 μ m repeatability, and a maximum speed of 2.0 m/s, X-BLQ-EC stages are perfect for rapid positioning over large distances. Like all of Zaber's products, the X-BLQ-EC Series is designed to be 'plug and play' and very easy to set up and operate.

For more information visit: <https://www.zaber.com/products/linear-stages/X-BLQ-EC>

X-BLQ-EC Series Part Numbering & Options

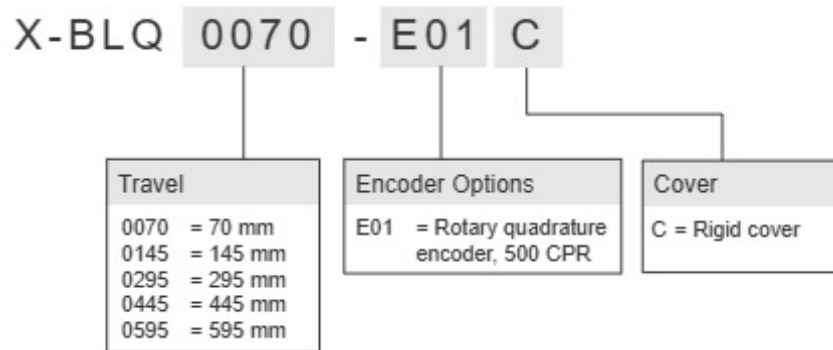

X-BLQ0295-E01C Drawings

- [X-BLQ-EC.png \(Drawing for the X-BLQ-EC\)](#)

X-BLQ0295-E01C Specifications

Microstep Size (Default Resolution)	4.21875 μm
Built-in Controller	Yes
Travel Range	295 mm (11.614")
Accuracy (unidirectional)	300 μm (0.011811")
Repeatability	< 20 μm (< 0.000787")
Backlash	< 75 μm (< 0.002953")
Maximum Speed	2000 mm/s (78.740"/s)
Minimum Speed	0.002576 mm/s (0.000101"/s)
Speed Resolution	0.002576 mm/s (0.000101"/s)
Encoder Resolution	500 CPR (2000 states/rev)
Encoder Type	Rotary quadrature encoder
Peak Thrust	55 N (12.3 lb)
Maximum Continuous Thrust	20 N (4.5 lb)
Communication Interface	RS-232
Communication Protocol	Zaber ASCII (Default), Zaber Binary
Data Cable Connection	Locking 4-pin M8
Maximum Centered Load	200 N (44.9 lb)
Maximum Moment (Pitch)	5 N-m (3.7 ft-lb)
Maximum Moment (Roll)	15 N-m (11.1 ft-lb)
Maximum Moment (Yaw)	5 N-m (3.7 ft-lb)
Vertical Runout	< 30 μm (< 0.001181")
Horizontal Runout	< 35 μm (< 0.001378")
Pitch	0.06° (1.047 mrad)
Roll	0.03° (0.523 mrad)
Yaw	0.03° (0.523 mrad)
Stiffness in Pitch	115 N-m/° (152 $\mu\text{rad/N-m}$)
Stiffness in Roll	145 N-m/° (120 $\mu\text{rad/N-m}$)
Stiffness in Yaw	110 N-m/° (159 $\mu\text{rad/N-m}$)
Power Supply	24-48 VDC
Maximum Current Draw	1800 mA
Linear Motion Per Motor Rev	54 mm (2.126")

Microstep Size (Default Resolution)	4.21875 μm
Motor Steps Per Rev	200
Motor Type	Stepper (2 phase)
Motor Rated Current	2300 mA/phase
Inductance	2.2 mH/phase
Default Resolution	1/64 of a step
Guide Type	Recirculating Ball Linear Guide
Mechanical Drive System	Synchronous belt
Limit or Home Sensing	Magnetic home sensor
Manual Control	Indexed knob with push switch
Axes of Motion	1
Mounting Interface	M6 threaded holes
Stage Parallelism	< 100 μm (< 0.003937")
Operating Temperature Range	0 to 50 °C
CE Compliant	Yes
Vacuum Compatible	No
Weight	2.4 kg (5.291 lb)

X-BLQ-EC Series Charts

Thrust Speed Performance

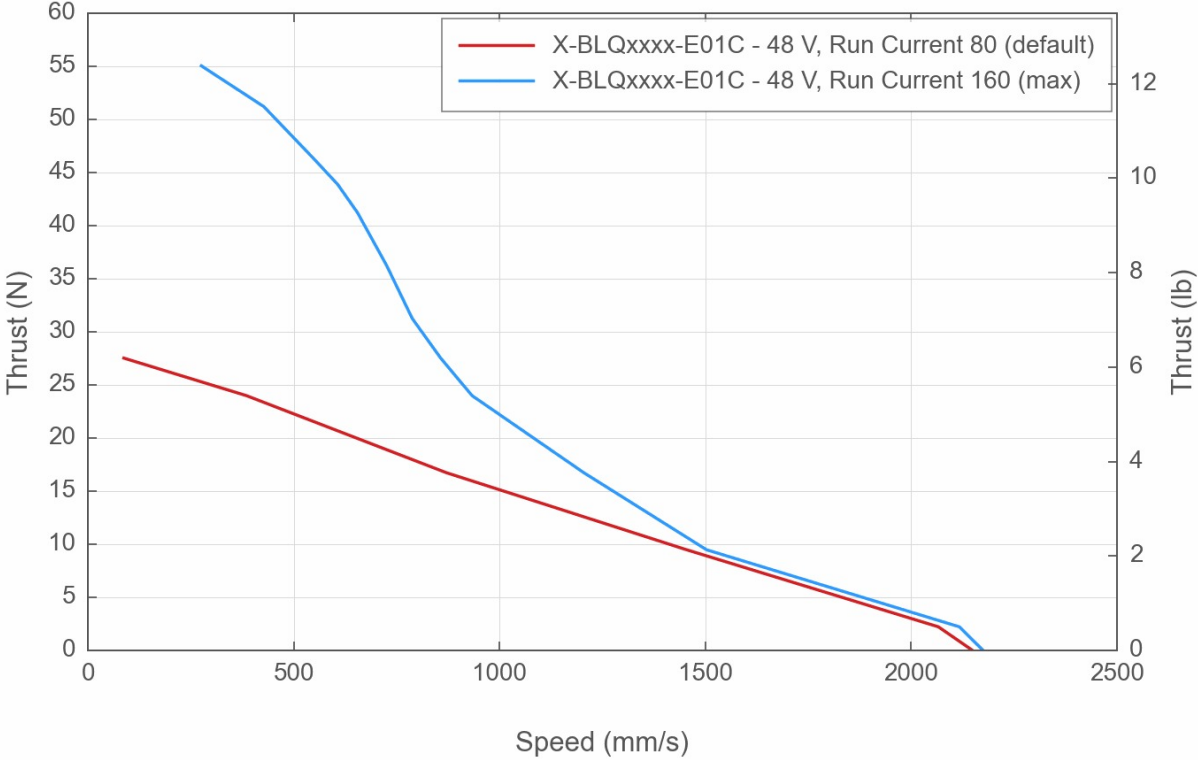

Horizontal Acceleration

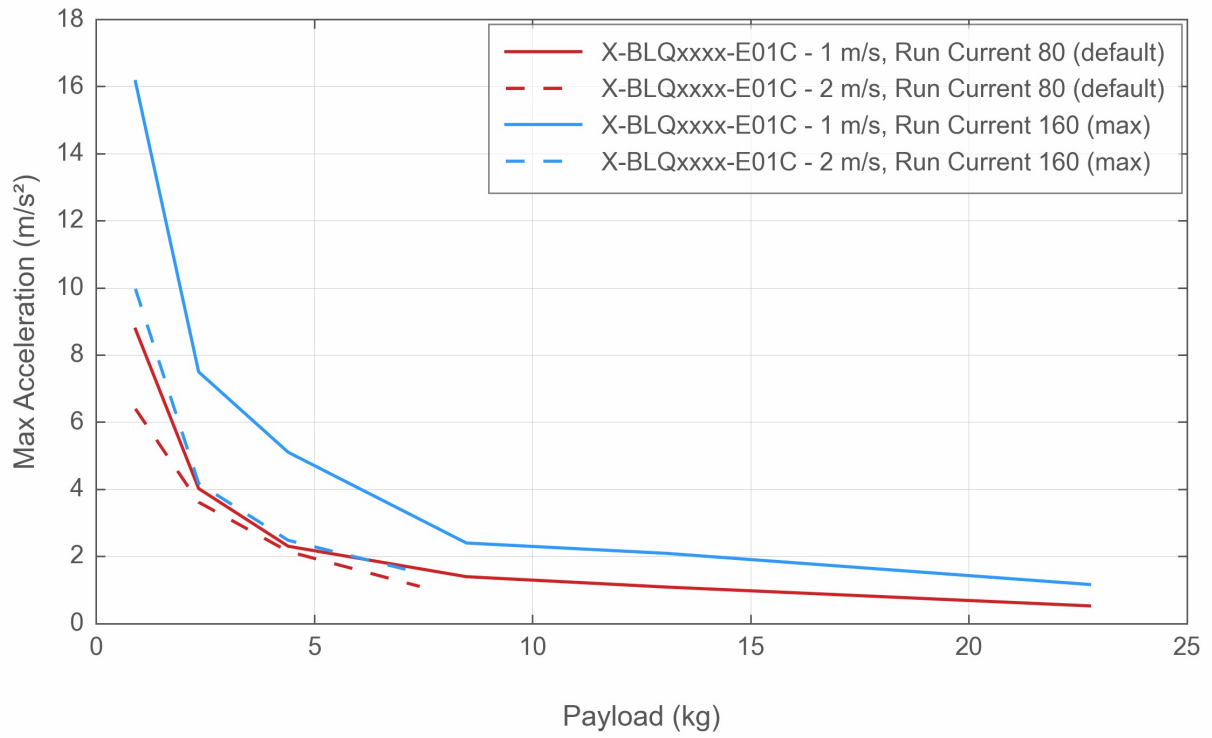

Typical Accuracy

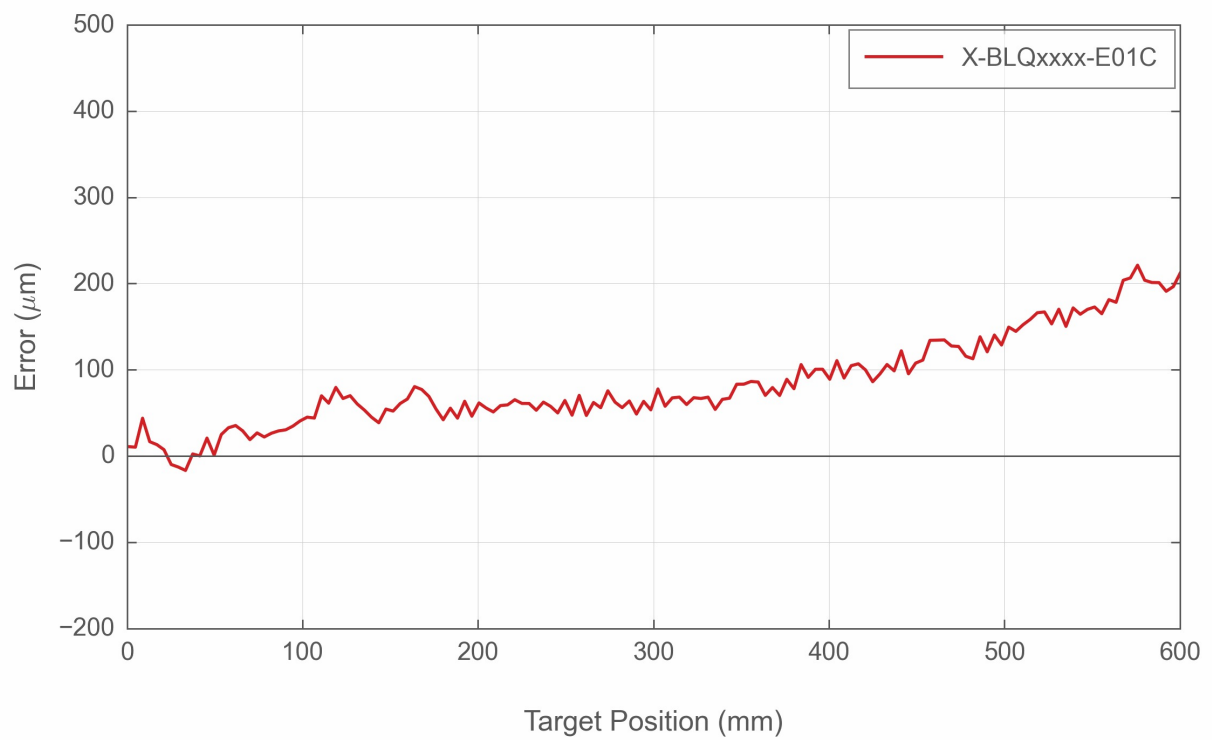

Contact

Email: contact@zaber.com

Phone (toll free Canada/USA): 1-888-276-8033

Phone (direct): 1-604-569-3780

Fax: 1-604-648-8033

Zaber Technologies Inc.

#2 - 605 West Kent Ave. N.

Vancouver, British Columbia

Canada, V6P 6T7

<https://www.zaber.com>