

X-LDQ-AE Series User's Manual

High speed, precision linear motor stages with built-in controllers and linear encoders

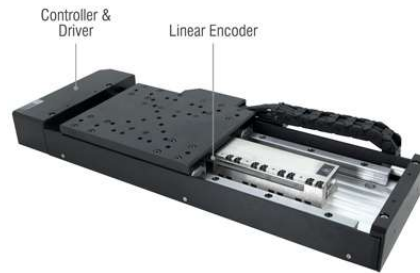

Disclaimer

Zaber's products are not intended for use in any critical medical, aviation, or military applications or situations where a product's use or failure could cause personal injury, death, or damage to property. Zaber disclaims any warranty of fitness for a particular purpose. The user of this product agrees to [Zaber's general terms and conditions of sale](#).

Precautions

Zaber's motion control devices are precision instruments and must be handled with care. In particular, moving parts must be treated with care. Avoid axial loads in excess of the rated thrust load, axial and radial impact, dust and other contaminants and damage to the drive components. These will reduce the performance of the device below stated specifications.

⚠ Mounting and Maintenance Hazard! For operator safety, the X-LDQ-AE should always be un-powered during all cleaning, maintenance, and stage or load mounting operations. A powered stage could exert high forces and move at high speeds very suddenly if accidentally given a move command.

Shipping Safety

Upon receipt of the stage, remove the two straps securing the stage top before attempting to power-up the stage. If transporting or shipping the stage, it is recommended that replacement straps be installed to prevent the carriage from moving during shipping.

Important Precautions for Use

⚠⚠ Strong Magnets! The X-LDQ-AE stages contain strong magnets that could affect pacemaker function. Pacemaker users should stay at least 20 cm away from the stages. The magnets can also attract nearby magnetic objects. Use caution when mounting the device as fasteners and tools can easily be pulled into the magnet track. Use non-magnetic fasteners and tools whenever possible.

⚠ Secure Stage Mounting Required! The X-LDQ-AE stages are heavy and can shake and vibrate during operation due to high inertia. The stages must always be securely mounted to a work surface during operation. See [#Physical Installation](#) for information on stage mounting.

💡 Important: The X-LDQ-AE stage should be homed immediately upon power-up. Behavior may appear jerky during homing. Once the stage has been homed, motion will be controlled and smooth.

⚠ Back-driving Hazard! Linear motor stages require current to the motor coils to provide a force to maintain position and/or support a load. If power is removed the carriage may move suddenly or in an uncontrolled manner. The X-LDQ-AE stage is not intended for load lifting operations due to the risk of uncontrolled motion if driver power is removed.

💡 Important: The X-LDQ-AE is a servo device, meaning that its performance is dependent on proper tuning of the servo parameters for the given load. The use of incorrect servo parameters may reduce the device's performance in operation. Incorrect tuning may also result in unstable operation, which can cause unexpected rapid motion of the device, leading to reduced device lifetime and user injury. When the operating load on the device is changed, the tuning parameters should be updated to match. For details see the servo tuning guidelines.

Lubrication of Linear Guides

Many factors affect the lifetime of the grease and bearings including duty cycle, environment, travel length, stage orientation, and loading configuration. As a general guideline for usage in a clean office environment, the recommended re-lubrication interval is 250 km with an inspection after every 1500 hours of continuous operation. Inspection should be done by wiping a bearing rail with a clean, lint-free wipe and ensuring that there is clean, wetted grease present.

Harsh environment, short travel, vertically oriented, and high duty cycle applications require more frequent re-lubrication and inspection. Contact an Applications Engineer to discuss your application for more specific recommendations.

Short travel can cause an insufficient distribution of lubricant amongst the rolling elements of the bearing system. For recirculating bearing guide types, short travel is equal to or less than the length of the carriage. For crossed-roller bearing guide types, short travel is equal to or less than twice the spacing of the rolling elements (typically 5-6 mm). If your application is considered short travel, it is recommended to occasionally drive the stage throughout its full travel range to maintain an even lubrication film over the entire guide surface. More frequent re-lubrication and inspection may be required in these applications.

Contact [Zaber support](#) for [relubrication kit SG133](#). We recommend using Shell Gadus S2 V220 2 or similar lithium thickened petroleum grease.

We recommend using 0.2 cm³ per bearing block of grease. All guides come pre-lubricated and are ready to go out of the box.

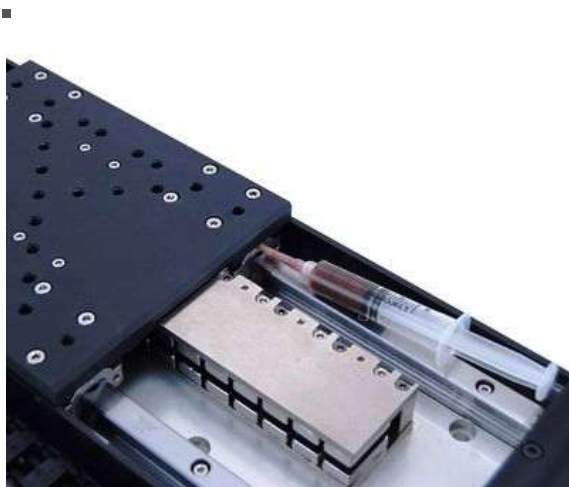

1. **Remove power** to the device before attempting to lubricate.
2. Re-lubricate at four of the ports shown above on the stage.

Encoder Care and Cleaning

The X-LDQ-AE uses a high precision, optical linear encoder for position feedback. The read head is mounted out of harm's way under the stage top, but the tape scale is mounted to the side of the motor (shown below) and can be damaged if care is not used when mounting the device. Avoid contacting the tape scale with tools and fasteners. Should the device be used in a dusty environment and debris is deposited on the tape scale, the encoder signal strength may be compromised and cleaning will be required. Using a dry, lint free wipe, gently wipe the scale along the travel of the device to clean the scale.



Remove power to the device before attempting to clean the tape scale with a dry, lint free wipe

Cable Chain Care

The X-LDQ-AE uses a polymer cable chain to protect and guide the cable assemblies for the motor and encoder. It is a robust guide but care must be taken to ensure its functionality and longevity. Do not grab the chain with the intent to move, reposition, or lift the stage. Ensure that during operation, the chain is allowed to move freely without it sliding on or impacting a stationary surface

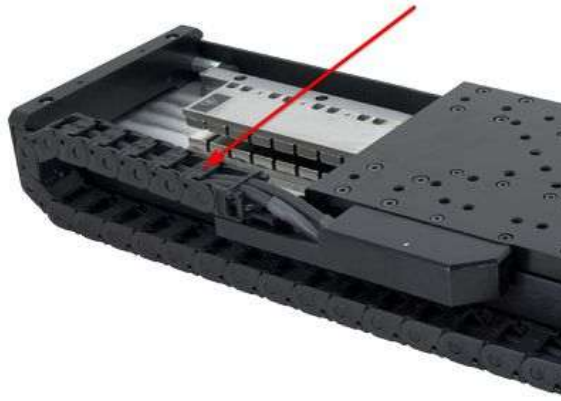

Do not grab the chain with the intent to move, reposition, or lift the stage.

Noise Emissions

The A-weighted emission sound pressure level (SPL) of this device does not exceed 70 dB(A) during intended use.

Conventions used throughout this document

- Fixed width type indicates communication to and from a device. The μ symbol indicates a carriage return, which can be achieved by pressing enter when using a terminal program.

Quick Tutorial

We recommend using [Zaber Launcher](#) to communicate with the device(s). For other software options, see the [Software](#) page. Please refer to the [Protocol Manual](#) for more detailed information on the available commands.

Initial Set-up



- Daisy chain all integrated devices and controllers together using the RS-232 "Prev" and "Next" connectors (see [Daisy-Chaining Devices](#) for more details).
- Next, supply power to one or more devices. Many products share power through the daisy-chain cables. The green power indicator on each should light up.
- Turn the knob to move a positioner. Most positioners will only move in one direction until they reach a home sensor at one limit of travel. Then they will move in both directions over full travel.
- Download and install [Zaber Launcher](#). Start Zaber Launcher.
- Create a New Connection and select the communications port the first controller is connected to. For instructions on how to find the available communication ports on your system, please refer to: [Appendix A - Available Communications Ports](#).
- If multiple devices are detected and there are conflicting device numbers, Zaber Launcher will renumber them or you can [renumber](#) them as desired. The first device in the chain (closest to the computer) will become Device 1, the next will become Device 2, and so on.

Initialization

Every time the device is powered up or reset, you should return the positioner to the home position. This is achieved by sending the [home](#) command to the individual device or all devices. Until this is done, most positioners will only allow motion in one direction, towards the sensor.

Using the Device

Several commonly used ASCII commands are shown below. For a full list of available commands, please refer to the [Protocol Manual](#).

Command	Description
/1 1 get pos	Query the current position of Device #1 Axis #1.
/1 1 move abs 10000	Move Device #1, Axis #1 to position 10000 encoder counts.
/2 1 move rel -12800	Move Device #2, Axis #1 in the negative direction by 12800 encoder counts.
/1 stop	Decelerate and stop ALL axes on Device 1. An axis number of 0 or no axis number implies all axes on the device, or the device itself.
/ move vel 153600	Move ALL devices and ALL axes in the positive direction at the speed 153600. A device address of 0 or no device address implies all devices in the chain.

Modifying Device Settings

Here are some examples if you would like to customize particular device or axis settings. Refer to the [Protocol Manual](#) for detailed descriptions of each setting.

Command	Description
/1 set maxspeed 100000	Set the speed of all axes on the device.
/1 get maxspeed	Query the maximum speed of all axes on the device.
/1 system restore	Restore all the settings of Device 1 to the default.

Firmware Upgrades

To allow access to new features and bug fixes, this Zaber device can be upgraded remotely through the Firmware Upgrade app in Zaber Launcher. In the "My Connections" window, click on the "..." menu to the right of the device and select "Firmware Upgrade".

Device Overview

Connectors

All images are shown looking into the device.

Power

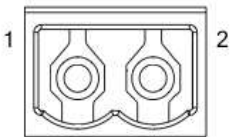
	Pin	Description
	1	24 - 48 V
	2	Device GND

Note: This product requires a CE/UL approved AC/DC power converter such as Zaber's PS13S, PS14S or PS15S with a DC cord of at most 3 m.

Note: As of February 2022, the power supplies Zaber provides are isolated and thus the device is not connected to Earth ground. Prior to 2022, most power supplies were non-isolated. Isolated units can be distinguished by the "S" suffix in their Zaber part number (eg. PS14S), which is marked on the label on the bottom of the power supply.

RS-232 Communications

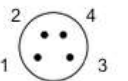
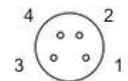
		Pin	Previous	Next
		1	Power (max 4 A)	Power (max 4 A)
		2	Ground	Ground
		3	Receive	Transmit
		4	Transmit	Receive

Default Settings

- Baud rate: 115200

- Protocol: Zaber ASCII

Specifications

- Supported Protocols: Zaber ASCII
- Supported baud rates: 9600, 19200, 38400, 57600, 115200
- Bits: 8
- Parity: None
- Stop Bits: 1
- Flow Control: None

D12 IO pinout

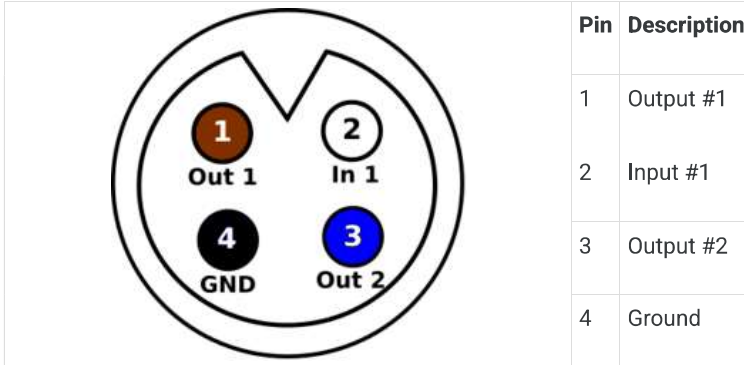

Note: See [I/O Usage and Examples](#) for additional information.

Note: Any cables connected to the I/O port should be limited to 3 m in length.

Other Connectors

For any connections not described in this document, cables should be limited to a length of 3 m.

Indicators

Green (Device) - Power

- On: Controller is operational.
- Blinking twice per second: The power supply voltage or controller temperature is out of range.

Red (Device) - System Error

- On/blinking: An error has occurred. Please contact [Zaber Technical Support](#).

Yellow (Device) - Communication

- On: Data is being transferred.
- Blinking twice per second: Packet corruption has occurred for ASCII commands sent with a checksum.

Yellow (Axis) - Axis Status

- On: Axis is moving.
- Blinking: Axis is under manual control via the knob (in Velocity mode). The blinking rate is proportional to movement speed.

Blue (Axis) - Warning/Error

- Blinking twice per second: Driver is disabled due to over-temperature, out-of-range voltage or other driver fault; or due to user request. See [Fx Warning Flags](#). *Note: This may occur for a few seconds on power-up as device initializes.*
- Blinking once every 2 seconds: The axis has stalled and stopped.
- Flashes: The stationary axis has been forced out of position (2 short flashes every 1 second), or the encoder has encountered a read error and raised the [FQ warning flag](#) (5 short flashes every 2 seconds).

Installation

The X-LDQ-AE can be connected to a computer as follows:

- Plug the M8 to USB adaptor ([X-USBDC](#)) into one of your computer's USB ports, then attach the device to the adaptor. You may need to use a cable extension to reach your computer. There is no need to power down or reboot the computer.

- Connect the power plug of your power supply to the power connector of the device. The green LED should light up indicating the device has power.
- Additional devices can simply be daisy-chained to the first. See [Daisy-Chaining Devices](#) below.
- Install software from the [Software](#) page. For the initial setup, using [Zaber Launcher](#) is recommended.



As a simple first test, try entering:

```
/renumber↵
/1 home↵
/1 move_rel 10000↵
```

The parameter of 10000 in the move command above specifies 10000 encoder counts. To see the encoder count size (default resolution) for the positioner and how it translates to displacement, first go to the [product overview](#) page, find your product, click through to the product's webpage, and click on the "Series Specs" tab. The encoder count size (default resolution) will be shown in the list of product specs either in the "Group Specifications" section or the "Comparison" section.

Daisy-Chaining Devices

Multiple devices can be connected together in a chain through the Prev and Next connectors. This allows any number of devices to be controlled from a single connection to a computer, reducing cabling demands. In addition, X-Series devices carry power through the daisy chain, so in most cases a power supply only needs to be connected to one device in the chain. Whenever a device is added or removed from a chain, a [renumber](#) command should be sent to prevent device address conflicts. If there are device address conflicts, Zaber Launcher will renumber automatically the next time you use it to connect to the chain.

Note: Daisy-chaining devices with cable lengths exceeding 8 m (25 ft) is not recommended.



Physical Installation

Secure stages with M6 socket cap screws, 12 mm or longer. Two stages can be mounted directly in XY configuration.

💡 **Tip:** To obtain the best pitch, roll, yaw and runout accuracy, mount the stage to a known flat, stiff surface. Our tests were performed on a granite table, grade A flatness.

⚠ Tipping Hazard! Ensure stage is fastened to a secure surface before mounting load on carriage. An unmounted stage with a load presents a tipping hazard. Ensure loads are mounted securely to the carriage of the stage.

Manual Control

Most X-Series motion control products have an integrated, depressible knob with 20 detents per revolution, allowing axes to be controlled without the use of a computer. There are two manual movement modes available: Velocity and Displacement. Switch between these modes by holding down the knob for 1 second or by configuring the [knob.mode](#) setting.

On power-up, many axes will only travel towards the home end from their start-up positions until the home position is reached. Once the axis has been homed, the full range of travel becomes available.

Velocity Mode

Turn the knob clockwise to move the axis in the positive direction (extend) or counter-clockwise for negative direction (retract). Each detent of the knob increases the speed of the carriage.

There are 16 speeds in each direction. The velocity profile and maximum speed can be configured via the [knob.speedprofile](#) and [knob.maxspeed](#) settings. The axis stops and resets the knob upon arriving at the end of travel.

Displacement Mode

Turn the knob clockwise to move the axis in the positive direction (extend), counter-clockwise for negative direction (retract). Each detent of the knob moves the axis a fixed number of encoder counts, specified by the [knob.distance](#) setting. If [knob.distance](#) is set to 0, each detent of the knob will move to the next index position, similar to [move.index](#) movements. The axis moves at the speed specified by the [maxspeed](#) setting, or the slower of [maxspeed](#) and [limit.approach.maxspeed](#) if the axis has not been homed. If there are fewer than [knob.distance](#) encoder counts to the end of travel and another move is requested, the axis will move to the end of travel and then stop.

Summary of knob functionality

- Turning the knob:
 - Moves the axis in the direction of knob turn.
- Pressing the knob:
 - Decelerates and stops the axis (identical to a [stop](#) command).
 - Instantly stops the axis, if the axis is already decelerating.
 - Warning:** Stopping instantly may result in damage to the product and reduced lifespan. Use sparingly if the axis is under heavy load.
- Pressing and holding the knob for 1 second:
 - Toggles between Velocity Mode and Displacement Mode.

Trajectory Control and Behaviour

This section describes the behaviour of the axis trajectory when a movement command is issued.

Software Position Limits

The travel range of the axis is limited by the Minimum Position and Maximum Position settings. The factory settings for the axis are configured to match the physical travel range. If a customized range is desired, it can be changed by configuring the [limit.min](#) and [limit.max](#) settings to appropriate values. For the Current Position, query [pos](#).

Minimum Position

When the Current Position is less than the Minimum Position value, the axis cannot move in the negative direction.

Maximum Position

When the Current Position is greater than the Maximum Position value, the axis cannot move in the positive direction.

Movement Speed

The movement speed of the axis depends on axis status and various speed settings. If the axis has not been initialized by the [home](#) command or by moving towards the home end of the axis, movement speed will be constrained to fail-safe values. The home status of the axis can be determined by reading the [limit.home.triggered](#) setting.

Movement speed of the axis is specified below:

[move.vel](#)

The axis will move at the specified speed regardless of home status.

Knob movement in Velocity Mode

The axis will move at the specified speed regardless of home status.

The speed is specified by the [knob.speedprofile](#) and [knob.maxspeed](#) settings.

Other movement commands - when the axis has not been homed

The axis will move at the slower of the [maxspeed](#) and [limit.approach.maxspeed](#) settings.

Other movement commands - when the axis has been homed

The axis will move at the speed specified by the [maxspeed](#) setting.

Servo Tuning

This positioner is a closed-loop positioning servo system. It continuously monitors and corrects its position via the linear encoder. As with any servo system, the behaviour is dependent on the controller tuning. It comes pre-tuned out of the box with settings that are optimized for regular use under a light load. However, as with any closed-loop feedback system, the performance is load-dependent, and conditions significantly outside of the intended operating range have the potential for reduced performance or instability. Thus, if operation with large or unconventional dynamic loads is desired, or if the application demands specific performance characteristics, it may be necessary to tune the servo parameters. This may be conveniently done by using Zaber Launcher's Servo Tuner App, or [Zaber Motion Library's](#) ServoTuner API

Tip: Because servo positioners continuously monitor and correct position, it is necessary to specify how accurate and stable the final position must be at the end of the movement. Criteria required for the controller to report IDLE status after movement are specified using the [cloop.settle.tolerance](#) and [cloop.settle.period](#) settings. For applications requiring utmost precision, you may want to specify a smaller tolerance and longer period. Note that there is a direct, inverse relationship between settling time and [cloop.settle.tolerance](#), and the controller may never report IDLE status if the tolerance is too small.

I/O Usage and Examples

The X-LDQ-AE features one digital input and two digital outputs that operate on a +5 V supply and are TTL compatible. The input and output capabilities of the X-LDQ-AE can also be used with [triggers](#) to perform actions based on the current value of the I/O channel.

Digital Inputs

The input will draw up to 1 mA during operation.

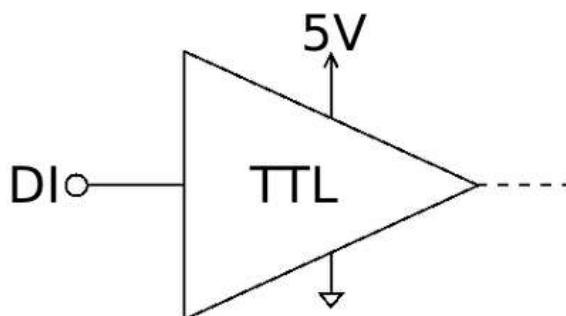

Reading the input is accomplished by sending the unit an [io.get.di](#) command, as shown below.

```
/1 io get di 1\r\n@01 0 OK IDLE -- 0
```

This command queries the input on the device, in this case input 1, which is low.

Digital Outputs

The digital outputs use an open collector buffer with a pre-installed 1 kΩ pull up resistor to +5 V. Each output can sink up to 20 mA.

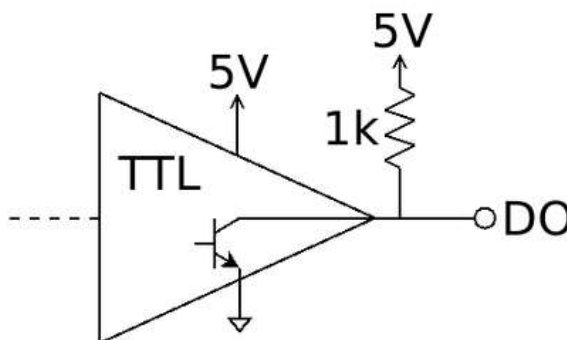

The digital outputs are set through the [io.set.do](#) command, as shown below.

```
/1 io set do 2 1␣  
@01 0 OK IDLE -- 0  
/1 io set do 1 0␣  
@01 0 OK IDLE -- 0
```

The first command sets the second digital output high (5 V). The second command sets the first digital output low (0 V).

Troubleshooting X-Series Motion Devices

The following sections contain tips for troubleshooting common problems. If the device is unable to communicate, and it is operating erratically, a manual factory reset can be performed on most devices using the following steps. Note that this will reset most settings.

- Power Off the device
- Push and hold the knob for the first Axis (if applicable)
- Power On the device
- Continue to hold the knob in (for ~5 seconds) until one or more LEDs are fading or the blue LED is lit, then release.
- The device has been returned to its factory defaults and can be configured as per the steps in [Initial Setup](#).

Front Panel Indicators

Green LED on.

The device is powered on and is operating normally.

Green LED flashes slowly.

The operating conditions of the device are outside of the recommended range.

This will occur when the supply voltage is either over or under the recommended range or the controller temperature has exceeded the set limit. Check the following:

- The input voltage is within the operational range of the device. This can be read from the device with the [get system.voltage](#) command.
- The device temperature is within range. This can be read from the device with the [get system.temperature](#) command.

Green LED off.

The device is not powered.

Check the supply connections and power adaptor for correct operation.

Red LED on or flashing.

A critical error has occurred.

Please contact [Zaber Technical Support](#).

Yellow LED always off or flashes but no reply.

There are communication errors.

Please see the [Communication Errors](#) section below.

Blue LED flashing during a move or blinking every two seconds.

The axis has slipped or stalled.

Please see the [Slipping and Stalling](#) section below.

Blue LED showing a burst of 2 flashes every 1 second.

A stationary axis has been forced out of position.

Blue LED showing a burst of 5 flashes every 2 seconds.

The encoder has encountered a read error.

Please contact [Zaber Technical Support](#).

Blue LED blinking twice per second. Axis does not move.

Driver may be disabled due to over-temperature, out-of-range voltage or other driver fault; or due to user request.

See [Fx Warning Flags](#).

Once the issue has been resolved, send [driver enable](#).

Manual Control

Turning the knob either way results in no movement.

The knob may have been disabled.

Check that the [knob.enable](#) setting is correct.

Restore the default parameters through the [system.restore](#) command.

The axis won't cover the full range of travel.

The axis hasn't been homed.

Turn the knob anti-clockwise until the axis reaches the fully retracted position. The axis will home and the full range of travel available.

Unexpected Behaviour

The axis doesn't respond to a move command.

The axis may need to be homed before use.

Send the [home](#) command.

The axis is moving on its own and running against the ends of travel.

The position encoder has de-synchronized.

Reset the device by power cycling it or sending the [system reset](#) command, then re-initialize it with the [home](#) command.

The axis is moving very slowly. It used to move faster.

The speed settings may have been changed inadvertently.

Send a [system restore](#) command.

The axis makes minor static-sounding noises even when stationary.

This condition happens if the closed-loop position controller is set to an aggressive servo tuning. It does not have an impact on the performance or lifetime of the stage, and is usually a normal operating condition.

Audible noise may be reduced or eliminated by lowering the servo gain. If the noise is very loud, then the gain needs to be reduced.

See the instructions on servo tuning.

The axis oscillates and has difficulty maintaining a fixed position.

The servo tuning may have been set incorrectly, or adjusted for a different load than what the axis is operating with.

See the instructions on servo tuning.

The axis consistently overshoots the target position position an unacceptable amount.

The acceleration setting may be too high for the load mass on the stage, or the servo tuning may be set inappropriately.

See the instructions on servo tuning.

The axis moves freely by hand and does not hold its position.

A setting might have been inadvertently changed.

- Try sending the [system reset](#) command.

The positioner's motor unexpectedly shuts off. An **Fx warning flag** is present.

The motor over-temperature protection switch has been tripped. This sensor will trip if the positioner's maximum continuous thrust specification is exceeded for too long. To prevent this condition from occurring again, reduce the average force that the motor outputs by reducing acceleration, reducing the load, or lowering the duty cycle.

Send a [driver enable](#) command. The axis does not require homing.

Communication Errors

There is no communication with the device; the Yellow LED does not come on or flash.

There are several things that should be checked:

- Make sure the correct serial port is selected. Try selecting other serial ports in the software.
- Check the baud rate, hand shaking, parity, stop bit, etc. when configuring the serial communications software. The required settings are listed in the [RS-232 Communications](#) section above.
- Make sure there are no bent pins in the ends of all the data cables
- Make sure the device is powered. The Green LED should be on.
- If the computer is a laptop running on batteries, try plugging in the power. Some laptops disable the serial ports when running on batteries.
- Make sure a null modem adaptor or cable is not being used.
- Make sure the correct adaptors (if any) are being used. Refer to the pinouts in the [RS-232 Communications](#) section above.
- If the problem was encountered when trying to control the device with custom software, try using [Zaber Launcher](#) to verify that the hardware is functioning properly.

Two or more devices both respond to commands sent to device 1.

Most devices are shipped with their device number set as 1. If you connect to the devices with Zaber Launcher, it will automatically renumber them if needed. If you aren't able to install and open Zaber Launcher, send the [renumber](#) command in the software you are using to set all of the device numbers to different values.

The Yellow LED comes on briefly when sending a command, but the axis does not move and does not reply.

Check baud rate, hand shaking, parity, stop bit, etc. are set as per the [RS-232 Communications](#) defaults.

The device numbers may not be what is expected, issue a [renumber](#) command. Make sure that the computer does not transmit anything else while the devices renumber.

Slipping and Stalling

The axis moves smoothly, but only moves for a short time then stops. The Blue LED is flashing but the axis is not actually slipping or stalling.

The internal encoder counter needs to be re-initialized. Reset the device by power cycling it or sending [system reset](#) command, then re-initialize it with the [home](#) command.

Ground the device and avoid operating it under statically noisy environment.

The axis makes noise but does not move. The Blue LED is flashing.

The axis is stalling.

Try removing all external loads. If the axis now extends and retracts normally, the problem is excessive load. Try to reduce the load and ensure the load is less than the maximum thrust. A higher thrust or torque can be achieved by lowering the speed of the axis using the [maxspeed](#) setting.

If an axis is stalling with no external load at default speed and acceleration settings then it requires servicing.

Warranty and Repair

For Zaber's policies on warranty and repair, please refer to the [Ordering Policies](#).

Standard products

Standard products are any part numbers that do not contain the suffix ENG followed by a 4 digit number. Most, but not all, standard products are listed for sale on our website. All standard Zaber products are backed by a one-month satisfaction guarantee. If you are not satisfied with your purchase, we will refund your payment minus any shipping charges. Goods must be in brand new saleable condition with no marks. Zaber products are guaranteed for one year. During this period Zaber will repair any products with faults due to manufacturing defects, free of charge.

Custom products

Custom products are any part numbers containing the suffix ENG followed by a 4 digit number. Each of these products has been designed for a custom application for a particular customer. Custom products are guaranteed for one year, unless explicitly stated otherwise. During this period Zaber will repair any products with faults due to manufacturing defects, free of charge.

How to return products

Customers with devices in need of return or repair should contact Zaber to obtain an RMA form which must be filled out and sent back to us to receive an RMA number. The RMA form contains instructions for packing and returning the device. The specified RMA number must be included on the shipment to ensure timely processing.

Email Updates

If you would like to receive our periodic email newsletter including product updates and promotions.

Contact Information

Contact Zaber Technologies Inc by any of the following methods:

Phone	1-604-569-3780 (direct) 1-888-276-8033 (toll free in North America)
Fax	1-604-648-8033
Mail	#2 - 605 West Kent Ave. N., Vancouver, British Columbia, Canada, V6P 6T7
Web	www.zaber.com
Email	Please visit our website for up to date email contact information.

The original instructions for this product are available at <https://www.zaber.com/manuals/X-LDQ-AE>.

Appendix A - Available Communications Ports

The following instructions outline how to find installed serial ports on your computer.

Windows

- Open Search or Run from the Start Menu or Taskbar, type "Device Manager" and press enter.



- Expand the Ports (COM & LPT) category.

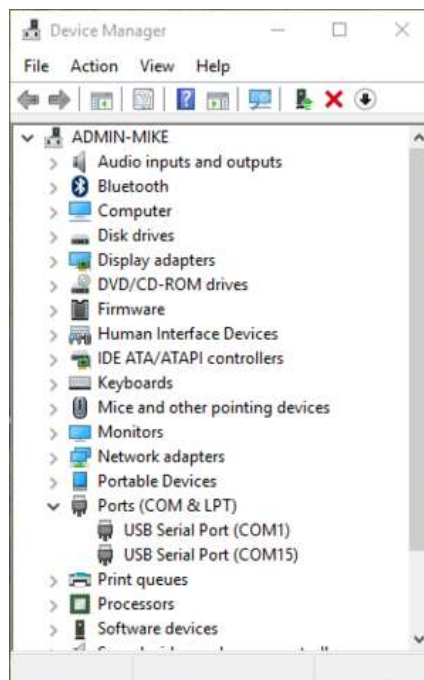

- In this example there are two serial ports available (COM1 and COM15), which are both USB adaptors.

Linux

- Finding devices

- Open a terminal and execute the following command:

```
dmesg | grep -E ttyU[0-9]*
```

- The response will be similar to the following:

```
[ 2.029214] serial8250: ttyS0 at I/O 0x3f8 (irq = 4) is a 16550A
```

```
[ 2.432572] 00:07: ttyS0 at I/O 0x3f8 (irq = 4) is a 16550A
```

```
[ 2.468149] 0000:00:03.3: ttyS4 at I/O 0xec98 (irq = 17) is a 16550A
```

```
[ 13.514432] usb 7-2: FTDI USB Serial Device converter now attached to ttyUSB0
```

- This shows that there are 3 serial ports available: ttyS0, ttyS4 and ttyUSB0 (a USB adaptor)

- Checking port permissions

- Using the ports found above, execute the following command

```
ls -l /dev/tty{S0, S4, USB0}
```

- The permissions, given below, show that a user has to be root or a member of the dialout group to be able to access these devices

```
crw-rw---- 1 root dialout 4, 64 Oct 31 06:44 /dev/ttyS0
```

```
crw-rw---- 1 root dialout 4, 68 Oct 31 06:45 /dev/ttyS4
```

```
crw-rw---- 1 root dialout 188, 0 Oct 31 07:58 /dev/ttyUSB0
```

- Checking group membership

```
groups
```

- The output will be similar to the following:

```
adm cdrom sudo dip plugdev users lpadmin sambashare
```

Notice that dialout is not in the list

- A user can be added to the dialout group with the following command

```
sudo adduser $USER dialout
```
- Group membership will not take effect until the next logon.

OSX

- Finding devices
 - Open a terminal and execute the following command:

```
ls /dev/cu.*serial*
```
 - The response will be similar to the following:

```
/dev/cu.usbserial-FTB3QAET  
/dev/cu.usbserial-FTEJJ1YW
```
 - This shows that there are two serial ports available, both of which happen to be USB adaptors.
 - There may be other devices that match this query, such as keyboards or some web cameras. To determine which one corresponds to your USB serial cable, try repeating the command with and without the cable connected to the computer, to see which one appears and disappears.

Product Drawing

ZABER

X-LDQ-AE Direct Drive Linear Stage
 dimensions in mm

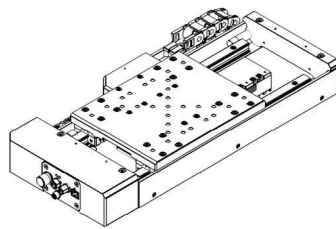

Model Number*	Travel	A	B	C	D
X-LDQ0075C-AE53D12	75.0	398.9	315.1	46.5	100.0
X-LDQ0150C-AE53D12	150.0	473.9	390.1	46.5	25.0
X-LDQ0300C-AE53D12	300.0	623.9	540.1	59.0	75.0
X-LDQ0450C-AE53D12	450.0	773.9	690.1	59.0	75.0
X-LDQ0600C-AE53D12	600.0	923.9	840.1	59.0	75.0
X-LDQ1000C-AE53D12	1000.0	1323.9	1240.1	71.5	75.0

*See product page for complete list of available models at www.zaber.com

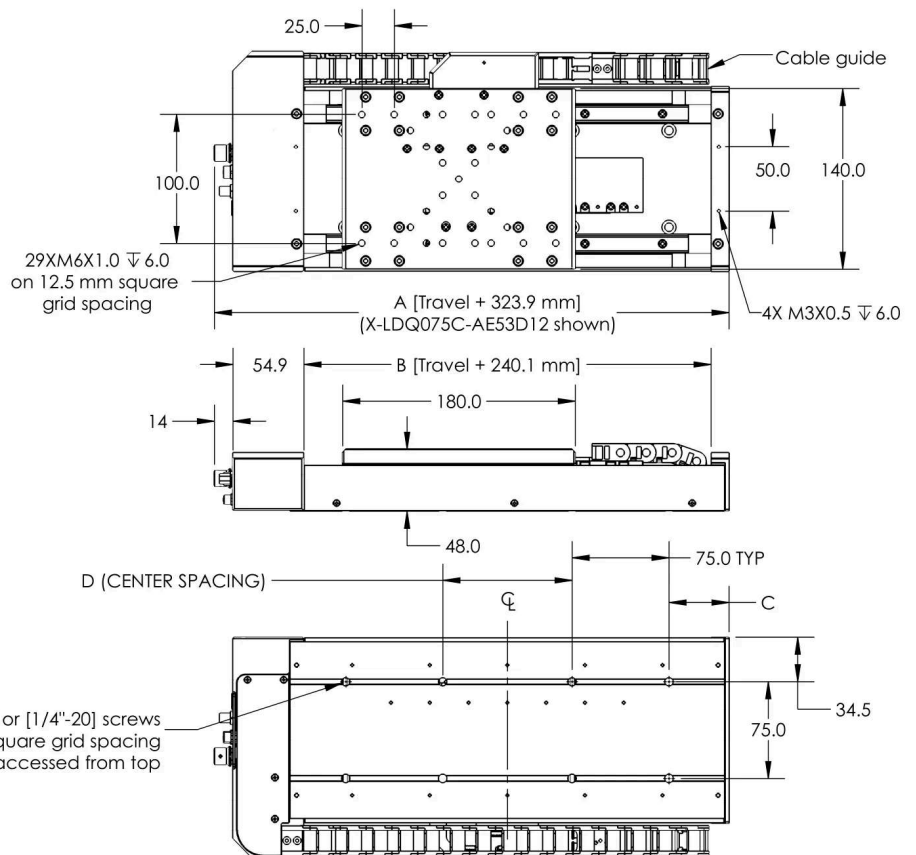
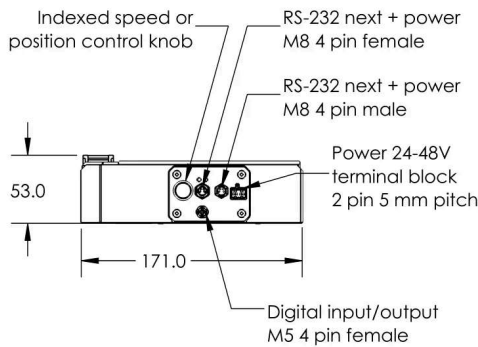

DWG 2030 R02D

Specifications

Specification	Value	Alternate Unit
Built-in Controller	Yes	
Accuracy (unidirectional)	2.5 μ m	0.000098"
Repeatability	< 0.3 μ m	< 0.000012"
Minimum Incremental Move	50 nm	
Maximum Acceleration	39.24 m/s ²	4.00 g

Specification	Value	Alternate Unit
Maximum Speed	1500 mm/s	59.055"/s
Minimum Speed	0.61 nm/s	
Speed Resolution	0.61 nm/s	
Encoder Type	Linear analog encoder	
Encoder Count Size	1 nm	
Peak Thrust	40 N	9.0 lb
Maximum Continuous Thrust	35 N	7.8 lb
Communication Interface	RS-232	
Communication Protocol	Zaber ASCII (Default)	
Data Cable Connection	Locking 4-pin M8	
Maximum Centered Load	200 N	44.9 lb
Maximum Moment (Pitch)	30 N·m	22.1 ft·lb
Maximum Moment (Roll)	30 N·m	22.1 ft·lb
Maximum Moment (Yaw)	30 N·m	22.1 ft·lb
Typical Velocity Stability	± 0.54% at 100 mm/s with a 5 kg payload	
Stiffness in Pitch	8000 N·m/°	2 μrad/N·m
Stiffness in Roll	3800 N·m/°	5 μrad/N·m
Stiffness in Yaw	4000 N·m/°	4 μrad/N·m
Power Supply	24-48 VDC	
Power Plug	2-pin screw terminal	
Maximum Current Draw	3000 mA	
Motor Type	Moving Coil Linear Motor	
Force Constant	15.8 N/A	3.5 lbs/A
Guide Type	Recirculating Ball Linear Guide	
Limit or Home Sensing	Optical Index Mark	
Manual Control	Indexed knob with push switch	
Axes of Motion	1	
LED Indicators	Yes	
Mounting Interface	M6 threaded holes	
Moving Mass	1.5 kg	3.300 lbs
Digital Input	1	
Digital Output	2	
Operating Temperature Range	0 to 50 °C	
CE Compliant	Yes	
Vacuum Compatible	No	

Comparison

Part Number	Travel Range	Vertical Runout	Horizontal Runout	Pitch
X-LDQ0075C-AE53D12	75 mm (2.953")	< 20 μm (< 0.000787")	< 6 μm (< 0.000236")	0.008° (0.140 mrad)
X-LDQ0150C-AE53D12	150 mm (5.905")	< 25 μm (< 0.000984")	< 12 μm (< 0.000472")	0.015° (0.262 mrad)
X-LDQ0300C-AE53D12	300 mm (11.811")	< 35 μm (< 0.001378")	< 25 μm (< 0.000984")	0.03° (0.523 mrad)
X-LDQ0450C-AE53D12	450 mm (17.716")	< 40 μm (< 0.001575")	< 30 μm (< 0.001181")	0.05° (0.873 mrad)
X-LDQ0600C-AE53D12	600 mm (23.622")	< 60 μm (< 0.002362")	< 50 μm (< 0.001968")	0.05° (0.873 mrad)

Part Number	Travel Range	Vertical Runout	Horizontal Runout	Pitch
X-LDQ1000C-AE53D12	1000 mm (39.370")	< 70 µm (< 0.002756")	< 70 µm (< 0.002756")	0.06° (1.047 mrad)

Part Number	Roll	Yaw	Weight
X-LDQ0075C-AE53D12	0.005° (0.087 mrad)	0.02° (0.349 mrad)	6.4 kg (14.110 lb)
X-LDQ0150C-AE53D12	0.008° (0.140 mrad)	0.025° (0.436 mrad)	7.3 kg (16.094 lb)
X-LDQ0300C-AE53D12	0.015° (0.262 mrad)	0.03° (0.523 mrad)	9.4 kg (20.723 lb)
X-LDQ0450C-AE53D12	0.02° (0.349 mrad)	0.035° (0.611 mrad)	10.9 kg (24.030 lb)
X-LDQ0600C-AE53D12	0.04° (0.698 mrad)	0.04° (0.698 mrad)	13.2 kg (29.101 lb)
X-LDQ1000C-AE53D12	0.06° (1.047 mrad)	0.06° (1.047 mrad)	18.6 kg (41.006 lb)

Typical Accuracy

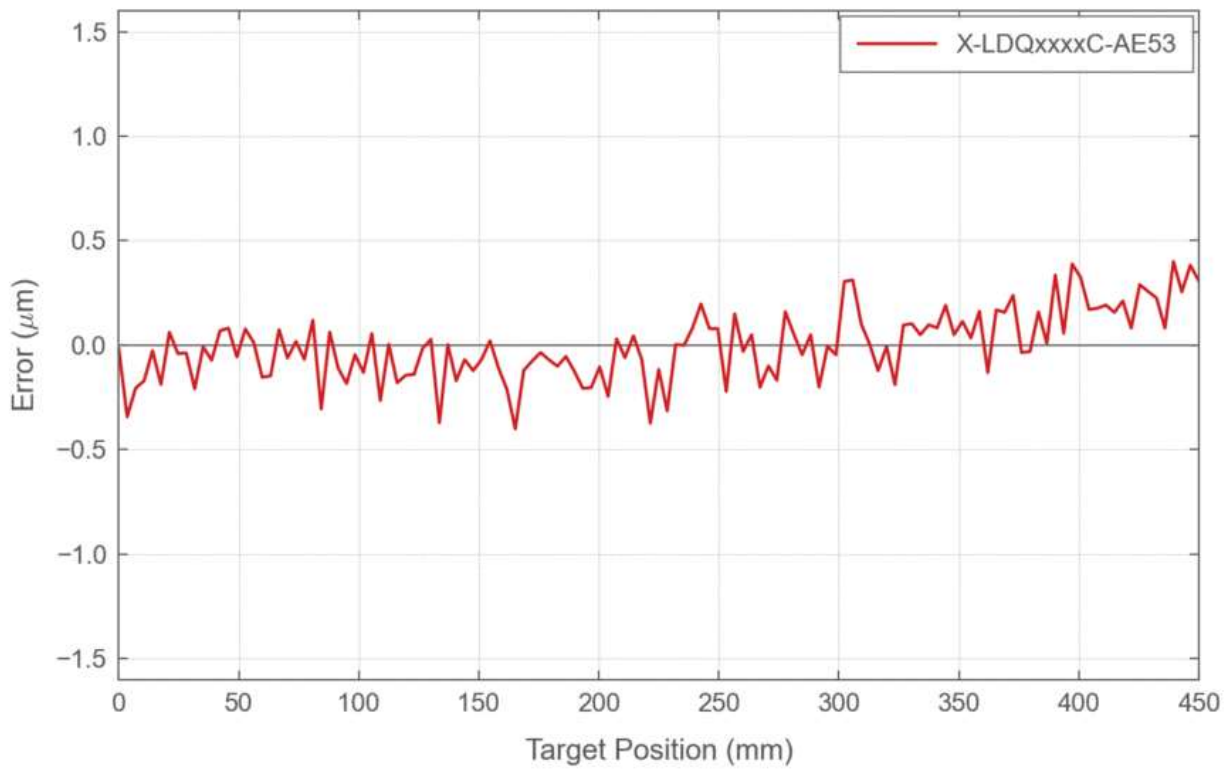

Typical Minimum Incremental Move

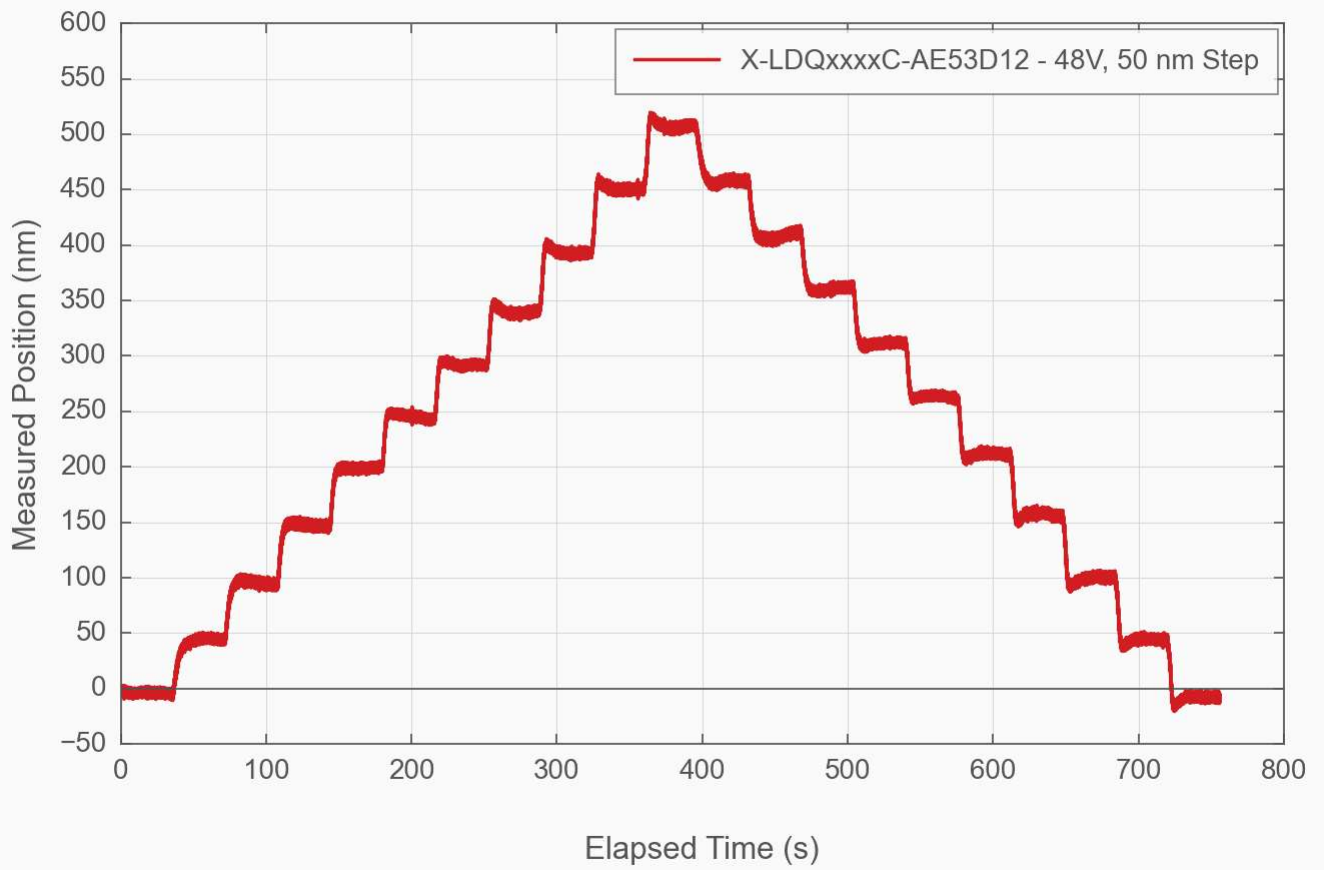

Typical Velocity Stability and Following Error

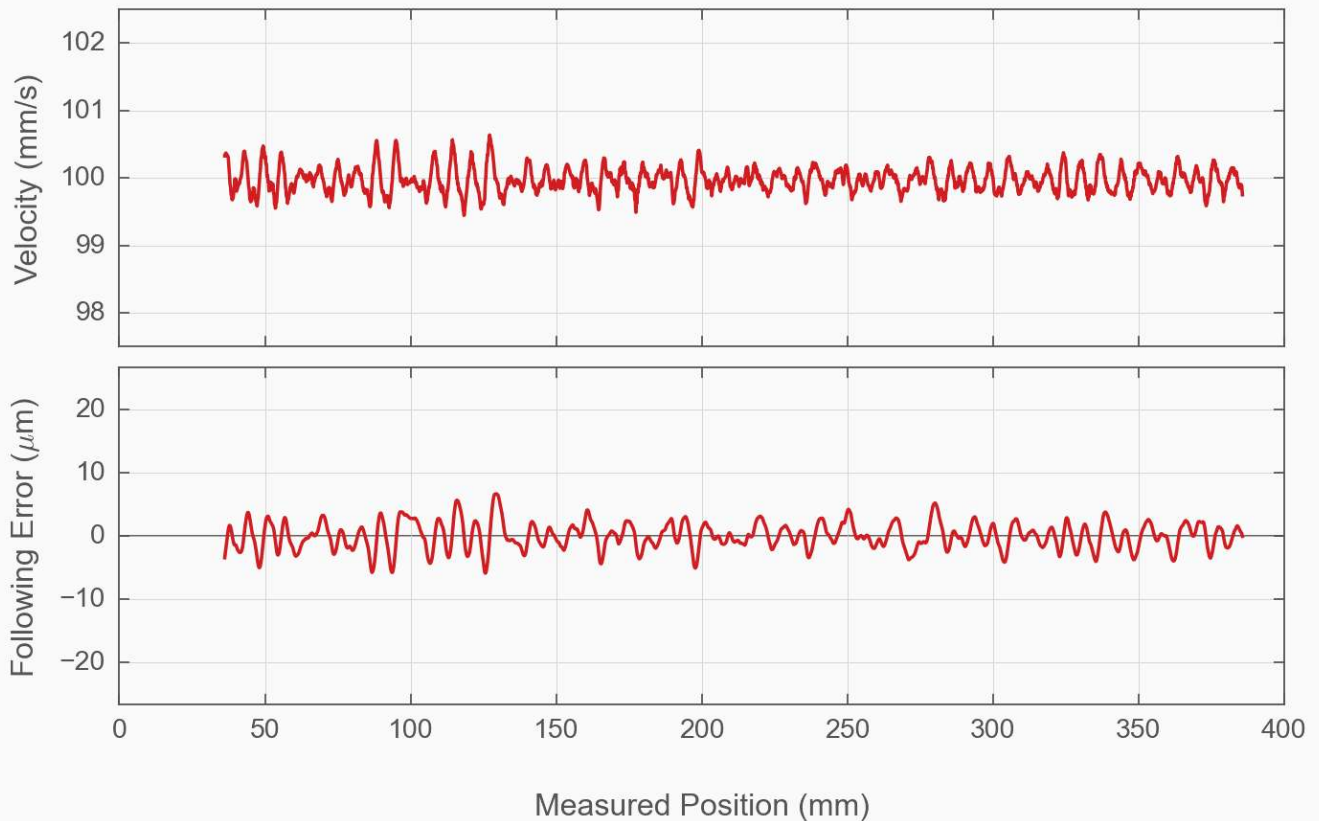

Product Change Notices

Click [here](#) to view the current product change notices and subscribe to future change notifications.

This product uses the FreeRTOS kernel. FreeRTOS is © 2026 Amazon.com, Inc. or its affiliates and is governed by the following license:

All rights reserved.

Permission is hereby granted, free of charge, to any person obtaining a copy of this software and associated documentation files (the "Software"), to deal in the Software without restriction, including without limitation the rights to use, copy, modify, merge, publish, distribute, sublicense, and/or sell copies of the Software, and to permit persons to whom the Software is furnished to do so, subject to the following conditions:

The above copyright notice and this permission notice shall be included in all copies or substantial portions of the Software.

THE SOFTWARE IS PROVIDED "AS IS", WITHOUT WARRANTY OF ANY KIND, EXPRESS OR IMPLIED, INCLUDING BUT NOT LIMITED TO THE WARRANTIES OF MERCHANTABILITY, FITNESS FOR A PARTICULAR PURPOSE AND NONINFRINGEMENT.

IN NO EVENT SHALL THE AUTHORS OR COPYRIGHT HOLDERS BE LIABLE FOR ANY CLAIM, DAMAGES OR OTHER LIABILITY, WHETHER IN AN ACTION OF CONTRACT, TORT OR OTHERWISE, ARISING FROM, OUT OF OR IN CONNECTION WITH THE SOFTWARE OR THE USE OR OTHER DEALINGS IN THE SOFTWARE.

This product uses the LZ4 compression library. LZ4 is © 2011–2016 Yann Collet and is governed by the following license:

All rights reserved.

Redistribution and use in source and binary forms, with or without modification, are permitted provided that the following conditions are met:

- Redistributions of source code must retain the above copyright notice, this list of conditions and the following disclaimer.
- Redistributions in binary form must reproduce the above copyright notice, this list of conditions and the following disclaimer in the documentation and/or other materials provided with the distribution.

THIS SOFTWARE IS PROVIDED BY THE COPYRIGHT HOLDERS AND CONTRIBUTORS "AS IS" AND ANY EXPRESS OR IMPLIED WARRANTIES, INCLUDING, BUT NOT LIMITED TO, THE IMPLIED WARRANTIES OF MERCHANTABILITY AND FITNESS FOR A PARTICULAR PURPOSE ARE DISCLAIMED. IN NO EVENT SHALL THE COPYRIGHT HOLDER OR CONTRIBUTORS BE LIABLE FOR ANY DIRECT, INDIRECT, INCIDENTAL, SPECIAL, EXEMPLARY, OR CONSEQUENTIAL DAMAGES (INCLUDING, BUT NOT LIMITED TO, PROCUREMENT OF SUBSTITUTE GOODS OR SERVICES; LOSS OF USE, DATA, OR PROFITS; OR BUSINESS INTERRUPTION) HOWEVER CAUSED AND ON ANY THEORY OF LIABILITY, WHETHER IN CONTRACT, STRICT LIABILITY, OR TORT (INCLUDING NEGLIGENCE OR OTHERWISE) ARISING IN ANY WAY OUT OF THE USE OF THIS SOFTWARE, EVEN IF ADVISED OF THE POSSIBILITY OF SUCH DAMAGE.