

ZABER

E-MCC3 EtherCAT Universal Motor Controller / Drive
Connectors and Indicators

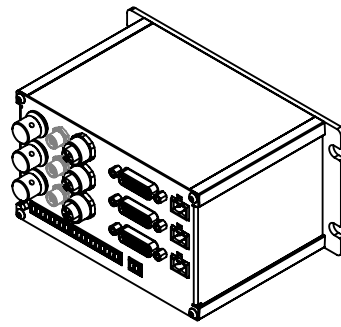

Model Number*	Encoder Output Connector
E-MCC3	None
E-MCC3-T7	M5 female, 4-pin
E-MCC3-T8	M8 male, 8-pin
E-MCC3-T15	M8 male, 8-pin
E-MCC3-T16	M8 male, 8-pin

*See product page for complete list of available models at www.zaber.com

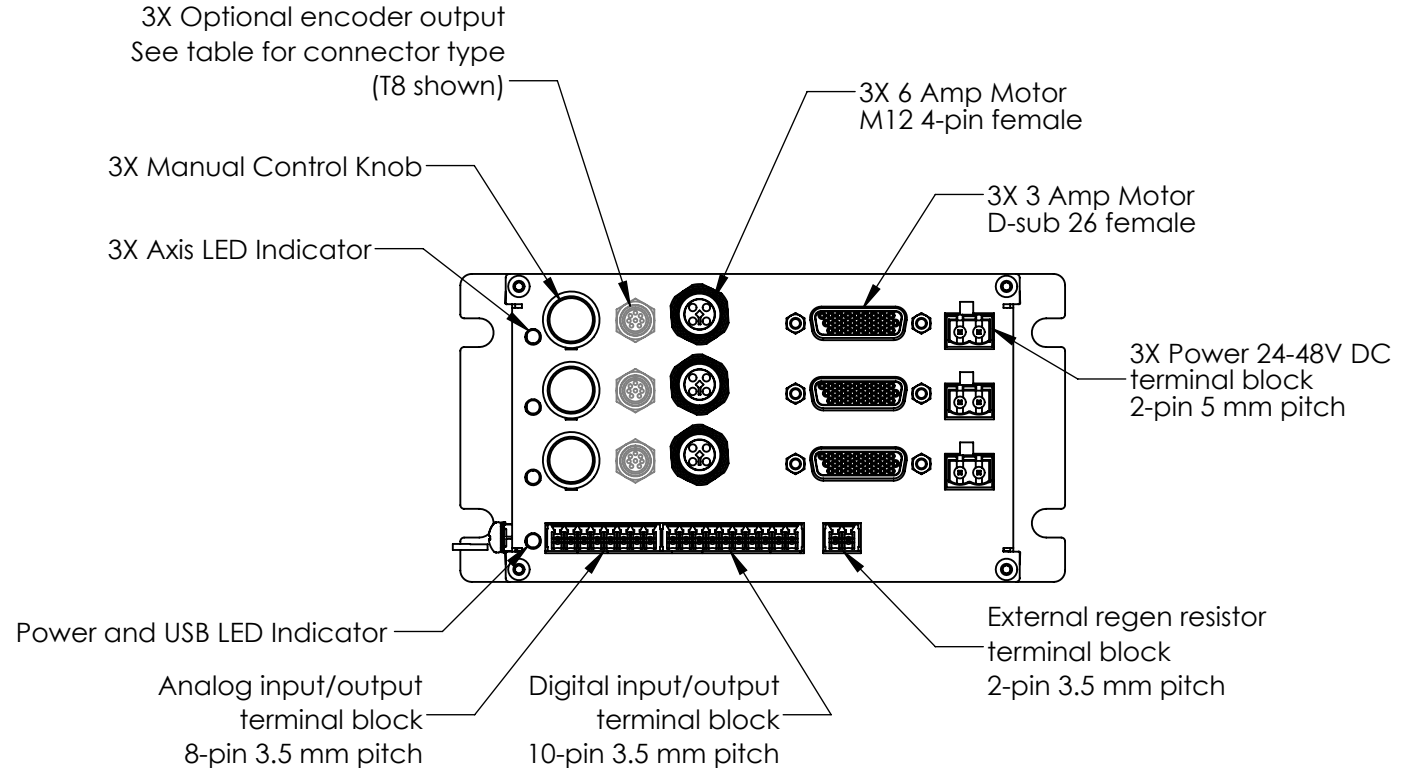
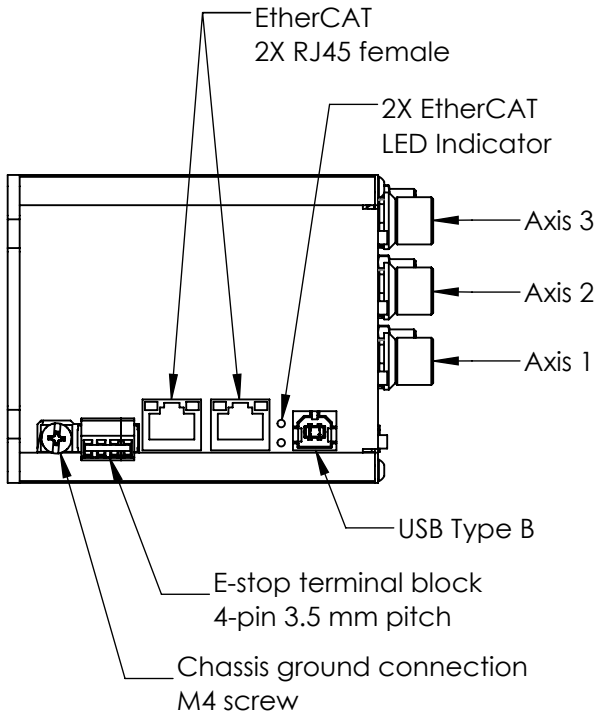

ZABER

E-MCC3 EtherCAT Universal Motor Controller / Drive
dimensions in mm

