

RSM Series User's Manual

Motorized rotation stages



Disclaimer

Zaber's products are not intended for use in any critical medical, aviation, or military applications or situations where a product's use or failure could cause personal injury, death, or damage to property. Zaber disclaims any warranty of fitness for a particular purpose. The user of this product agrees to [Zaber's general terms and conditions of sale](#).

Precautions

Zaber's autodetect peripheral axes are designed to be used effortlessly with Zaber's line of autodetect controllers. The RSM includes onboard memory that allows Zaber's controllers to autodetect the model and set reasonable parameters. See the [Protocol Manual](#) for more information on how to modify the settings. Damage to the axis may result if the settings are not correct. To use your Zaber peripheral with a third-party controller, review the motor, sensor, and encoder specifications and pin-outs carefully.

Zaber's rotary motion control devices are precision instruments and must be handled with care. In particular, moving parts must be treated with care. Avoid torque loads in excess of the rated maximum torque load, impact, dust and other contaminants and damage to the drive system. These will reduce the performance of the device below stated specifications.

Noise Emissions

The A-weighted emission sound pressure level (SPL) of this device does not exceed 70 dB(A) during intended use.

Conventions used throughout this document

- Fixed width type indicates communication to and from a device. The `\r` symbol indicates a carriage return, which can be achieved by pressing enter when using a terminal program.
- An [ASCII command](#) followed by (T:xx) indicates a legacy T-Series [Binary Protocol](#) command that achieves the same result. For example, `move abs 10000 (T:20:10000)` shows that a move abs ASCII command can also be achieved with Binary command number 20.

Not all ASCII commands have an equivalent Binary counterpart.

Device Overview

AutoDetect

Your RSM peripheral is equipped with AutoDetect, a feature that allows a Zaber controller to automatically configure its settings for the peripheral when it is connected.

⚠ Important: The controller should always be powered down before disconnecting or connecting your RSM peripheral.

To connect the peripheral to a controller:

- Power off the controller.
- Connect the RSM peripheral.
- Power on the controller.
- The controller will activate the peripheral shortly after it is powered on.

See the Zaber controller user manual for more details on peripheral activation and control.

Connectors

Recommended controller(s) for your RSM peripheral are provided in the product specifications. Zaber's controllers and peripherals are designed for ease of use when used together. Optimal settings for each peripheral are automatically detected by Zaber's controllers when the device is connected.

For reference, the pinout for the peripheral cable connectors is shown below:

Pinout for D-sub 15 Connectors (peripherals)

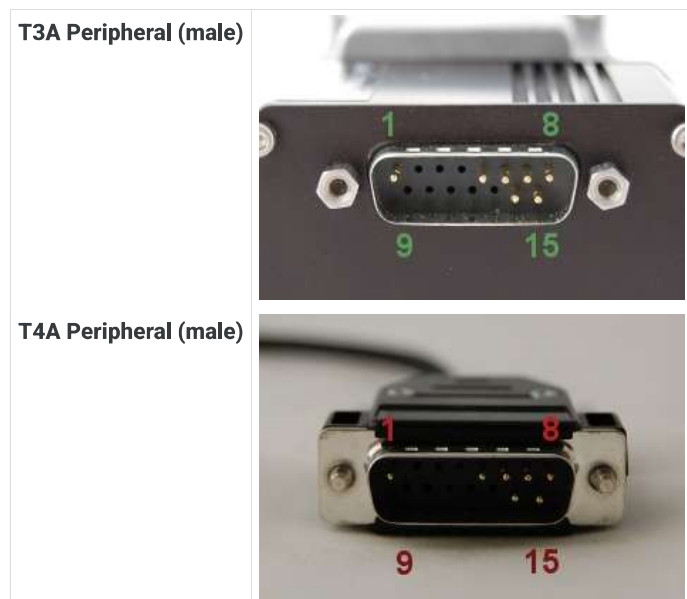

Pin #	Function
1	+5V for Limits & Encoder
2	AutoDetect Data
3	<i>reserved</i>
4	Away Sensor
5	Home Sensor
6	Ground
7	Motor B1
8	Motor A1
9	AutoDetect Clock
10	Encoder A
11	Encoder B
12	Encoder Index
13	Ground
14	Motor B2
15	Motor A2

Not all pins are used for all models

Alternate Controllers

The RSM can be controlled by any 2-phase stepper motor controller with limit sensor input. **We do not recommend using your own controller unless you are familiar with how to control a stepper motor with hall sensor limit switches.** Damage to the device due to incorrect wiring is not covered by warranty.

Motors

For motor information see the [RSM product page](#)

Limit Sensors

Hall effect sensors are used in the RSM as home sensors. The Hall sensors used are part number A1120LLHLT-T made by Allegro. [Click here for data sheet](#). Your controller should be configured so the stage stops immediately (quick deceleration) when the sensors are triggered.

- PCB wire colour code:
 - 5 Vdc input - red
 - Home signal - yellow
 - Away signal - white
 - Ground - black

The Hall sensor has an open-collector output. The default output is high impedance when the Hall sensor is not active. When the sensor detects a magnet, the Hall sensor pulls the output low to ground.

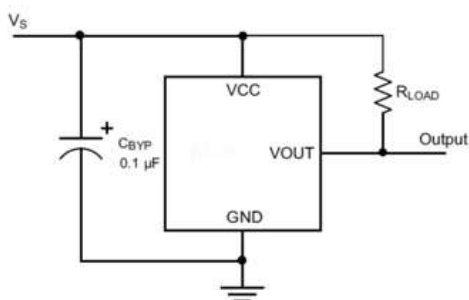

If you are not using a Zaber controller, ensure that your controller has a pull-up resistor on the output line of each Hall sensor as shown in the diagram. The bypass capacitor is optional, but may help to eliminate false triggering in noisy environments. The typical value for the pull-up resistor (R_{LOAD}) is 10 k Ω and for the bypass capacitor is 0.1 μ F to 1 μ F. The larger the capacitance, the better the noise filtering but the slower the response time.

Installation

Physical Installation

RSM stages can be mounted flat (with a vertical axis of rotation) or on edge (having a horizontal axis of rotation) without additional hardware. M3 x 16mm fasteners (included) are recommended for mounting the device. The rotation platform should be rotated 45 degrees from the home position to allow access to mounting holes. Edge mounting requires removal of the two M3 set screws shown below. These keep debris out of the main gear cavity when edge mounting is not needed.



The stage top may need to be rotated to access the mounting holes. A 2.5 mm hex key will also fit inside the manual knob and can be used to rotate the device manually



Remove the two indicated set screws with a 1.5 mm hex key before mounting the device on edge

Alignment

The RSM has several features to help align the axis of rotation.

A 4 mm bore through the centre of the device is concentric with the rotation axis and will fit tightly around a locating 4 mm diameter dowel pin inserted from either the top or the bottom of the device.

Four 5.5 mm diameter feet on the base of the device are intended to interlock with compatible Zaber devices and locate the rotation axis. These include [AP135](#) and [GSM](#) goniometer products. The RSM top is also compatible with these alignment bosses and can be used to align [AP146](#), [AB147](#), and [GSM](#) goniometers on the RSM stage top.

Three reference sides are intended for edge-mounting alignment. The [AP146](#) accessory is designed specifically to align with the edge features on the RSM stage.

Maintenance

To re-grease the worm gear:



Remove the middle set screw with a 1.5 mm hex key.



Apply grease with a syringe, moving the stage top through two rotations.



Reinstall the set screw so it is flush with the outside surface. Don't screw it deeper into the housing.

Trajectory Control and Behaviour

This section describes the behaviour of the axis trajectory when a movement command is issued.

Software Position Limits

The travel range of the axis is limited by the Minimum Position and Maximum Position settings. The factory settings for the axis are configured to match the physical travel range. If a customized range is desired, it can be changed by configuring the [limit.min \(T:106\)](#) and [limit.max \(T:44\)](#) settings to appropriate values. For the Current Position, query [pos \(T:60\)](#).

Minimum Position

When the Current Position is less than the Minimum Position value, the axis cannot move in the negative direction (towards the motor).

Maximum Position

When the Current Position is greater than the Maximum Position value, the axis cannot move in the positive direction (away from the motor).

Movement Speed

The movement speed of the axis depends on axis status and various speed settings. If the axis has not been initialized by the [home \(T:1\)](#) command or by moving towards the home end of the axis, movement speed will be constrained to fail-safe values. The home status of the axis can be determined by reading the [limit.home.triggered \(T:53:103\)](#) setting.

Movement speed of the axis is specified below:

[move vel \(T:22\)](#)

The axis will move at the specified speed regardless of home status.

Knob movement in Velocity Mode

The axis will move at the specified speed regardless of home status.

The speed is specified by the [knob.speedprofile \(T:112\)](#) and [knob.maxspeed \(T:111\)](#) settings.

Other movement commands - when the axis has not been homed

The axis will move at the slower of the [maxspeed \(T:42\)](#) and [limit.approach.maxspeed \(T:41\)](#) settings.

Other movement commands - when the axis has been homed

The axis will move at the speed specified by the [maxspeed \(T:42\)](#) setting.

Warranty and Repair

For Zaber's policies on warranty and repair, please refer to the [Ordering Policies](#).

Standard products

Standard products are any part numbers that do not contain the suffix ENG followed by a 4 digit number. Most, but not all, standard products are listed for sale on our website. All standard Zaber products are backed by a one-month satisfaction guarantee. If you are not satisfied with your purchase, we will refund your payment minus any shipping charges. Goods must be in brand new saleable condition with no marks. Zaber products are guaranteed for one year. During this period Zaber will repair any products with faults due to manufacturing defects, free of charge.

Custom products

Custom products are any part numbers containing the suffix ENG followed by a 4 digit number. Each of these products has been designed for a custom application for a particular customer. Custom products are guaranteed for one year, unless explicitly stated otherwise. During this period Zaber will repair any products with faults due to manufacturing defects, free of charge.

How to return products

Customers with devices in need of return or repair should contact Zaber to obtain an RMA form which must be filled out and sent back to us to receive an RMA number. The RMA form contains instructions for packing and returning the device. The specified RMA number must be included on the shipment to ensure timely processing.

Email Updates

If you would like to receive our periodic email newsletter including product updates and promotions.

Contact Information

Contact Zaber Technologies Inc by any of the following methods:

Phone	1-604-569-3780 (direct) 1-888-276-8033 (toll free in North America)
Fax	1-604-648-8033
Mail	#2 - 605 West Kent Ave. N., Vancouver, British Columbia, Canada, V6P 6T7
Web	www.zaber.com
Email	Please visit our website for up to date email contact information.

The original instructions for this product are available at <https://www.zaber.com/manuals/RSM>.

Appendix A: Default Settings

Please see [the Zaber Support Page](#) for default settings for this device.

Product Drawing

ZABER

RSM Motorized Rotary Stage
dimensions in mm

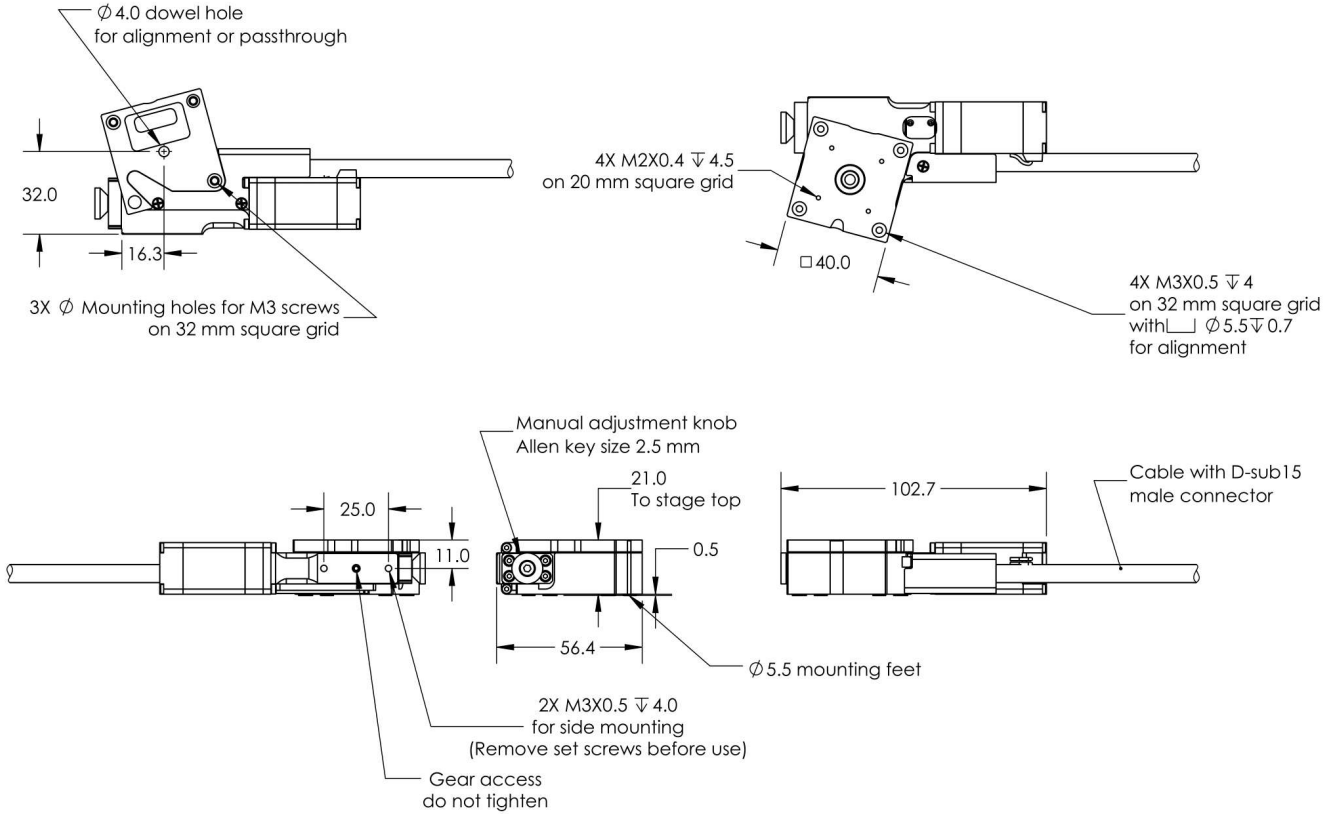
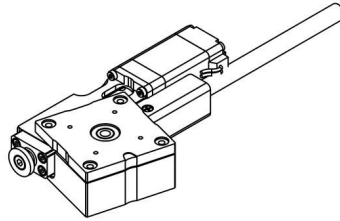

DWG 1707 R04

Specifications

Specification	Value	Alternate Unit
Microstep Size (Default Resolution)	0.00046875°	8.181 μrad
Built-in Controller	No	
Recommended Controller	X-MCC (48 V) Recommended	
AutoDetect	Yes	
Range	360°	
Accuracy (unidirectional)	0.14°	2.443000 mrad
Repeatability	< 0.02°	< 0.349 mrad
Backlash	< 0.04°	< 0.698 mrad
Maximum Speed	120°/s	20 rpm
Minimum Speed	0.000286°/s	4.992 μrad/s
Speed Resolution	0.000286°/s	4.992 μrad/s
Encoder Type	None	
Maximum Continuous Torque	60 N·cm	85.0 oz·in
Maximum Centered Load	50 N	11.2 lb
Maximum Moment (Transverse)	100 N·cm	141.6 oz·in
Stage Top Dimension	40 mm	1.575"
Radial Error Motion	+/- 10 μm	+/- 0.000394"

Specification	Value	Alternate Unit
Axial Error Motion	< 4 μm	< 0.000157"
Tilt Error Motion	+/- 0.011°	+/- 191.99 μrad
Bearing Plane Offset	11 mm	0.433"
Angular Motion Per Motor Rev	6°	
Motor Steps Per Rev	200	
Motor Type	Stepper (2 phase)	
Motor Rated Current	600 mA/phase	
Motor Winding Resistance	6.5 ohms/phase	
Inductance	3.5 mH/phase	
Motor Connection	D-sub 15	
Default Resolution	1/64 of a step	
Motor Frame Size	NEMA 08	
Mechanical Drive System	Precision Worm Gear	
Limit or Home Sensing	Magnetic home sensor	
Manual Control	Yes	
Mounting Interface	M2 and M3 mounting holes	
Operating Temperature Range	0-50 °C	
CE Compliant	Yes	
Vacuum Compatible	No	
Weight	0.24 kg	0.529 lb

Charts and Notes

Torque Speed Performance

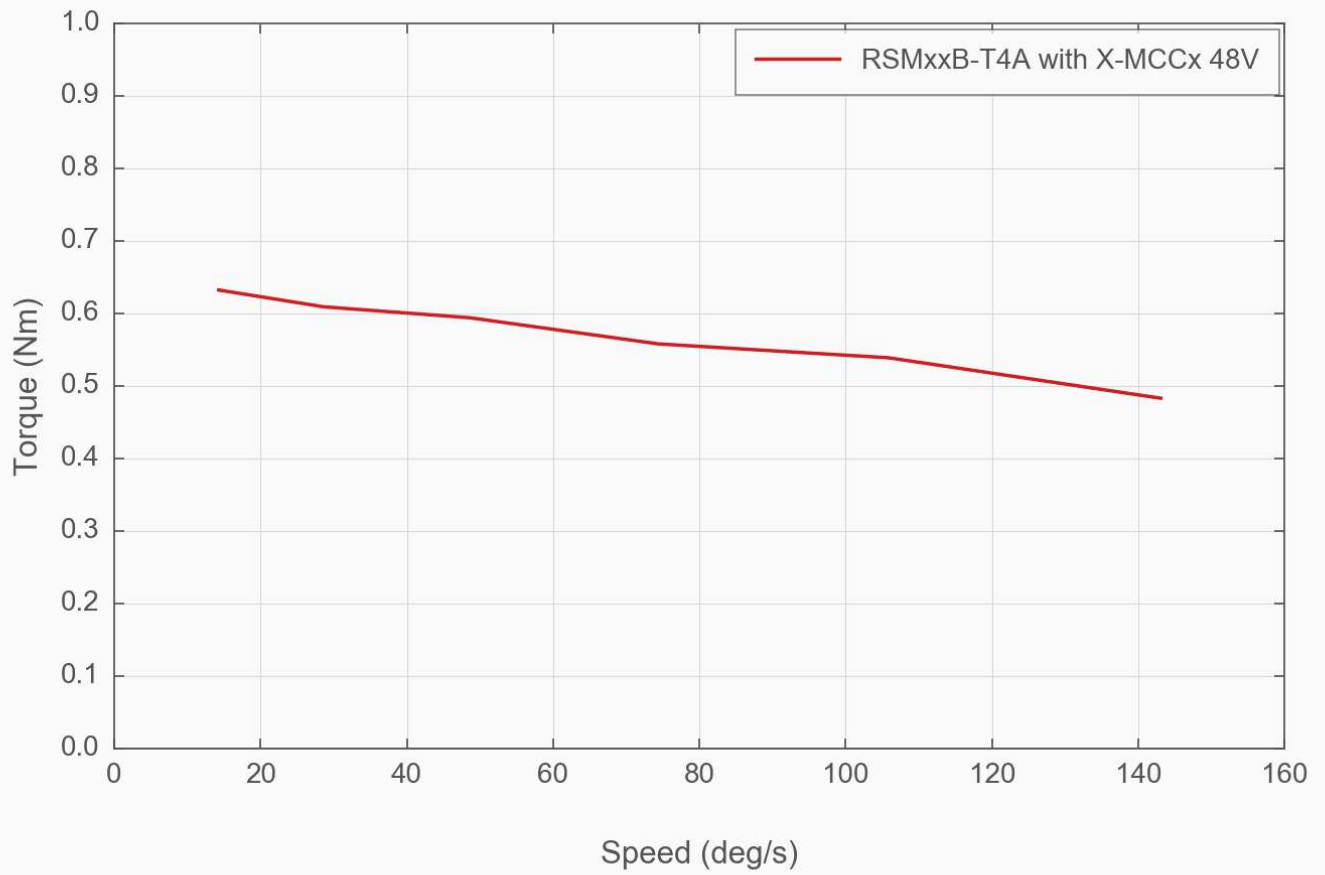

Product Change Notices

Click [here](#) to view the current product change notices and subscribe to future change notifications.