

# X-ADR-AE Series User's Manual

Linear motor XY microscope stages with built-in controllers and linear encoders



## Disclaimer

Zaber's products are not intended for use in any critical medical, aviation, or military applications or situations where a product's use or failure could cause personal injury, death, or damage to property. Zaber disclaims any warranty of fitness for a particular purpose. The user of this product agrees to [Zaber's general terms and conditions of sale](#).

## Precautions

Zaber's motion control devices are precision instruments and must be handled with care. In particular, moving parts must be treated with care. Avoid axial loads in excess of the rated thrust load, axial and radial impact, dust and other contaminants and damage to the drive components. These will reduce the performance of the device below stated specifications.

### Important Precautions for Use

Contamination could impact the performance of the X-ADR-AE stage. Avoid introduction of ferro-magnetic particles to the stage, and contact with, or contamination of, the encoder scale.

**⚠ Mounting and Maintenance Hazard!** For operator safety, the X-ADR-AE should always be un-powered during all cleaning, maintenance, and stage or load mounting operations. A powered stage could exert high forces and move at high speeds very suddenly if accidentally given a move command.

**⚠⚠ Strong Magnets!** The X-ADR-AE stages contain strong magnets that could affect pacemaker function. Pacemaker users should stay at least 20 cm away from the stages. The magnets can also attract nearby magnetic objects.

**⚠ Secure Stage Mounting Required!** The X-ADR-AE stages can shake and vibrate during operation due to high inertia. The stages must always be securely mounted to a work surface during operation. See [#Physical Installation](#) for information on stage mounting.

**💡 Important:** The X-ADR-AE stage should be homed immediately upon power-up. Behavior may appear jerky during homing. Once the stage has been homed, motion will be controlled and smooth.

**⚠ Back-driving Hazard!** Linear motor stages require current to the motor coils to provide a force to maintain position and/or support a load. If power is removed the carriage may move suddenly or in an uncontrolled manner. The X-ADR-AE stage is not intended for load lifting operations due to the risk of uncontrolled motion if driver power is removed.

**💡 Important:** The X-ADR-AE is a servo device, meaning that its performance is dependent on proper tuning of the servo parameters for the given load. The use of incorrect servo parameters may reduce the device's performance in operation. Incorrect tuning may also result in unstable operation, which can cause unexpected rapid motion of the device, leading to reduced device lifetime and user injury. When the operating load on the device is changed, the tuning parameters should be updated to match. For details see the servo tuning guidelines.

## Lubrication and Cleaning

Many factors affect the lifetime of the grease and bearings including duty cycle, environment, travel length, stage orientation, and loading configuration. As a general guideline for usage in a clean office environment, the recommended re-lubrication interval is 250 km with an inspection after every 1500 hours of continuous operation. Inspection should be done by wiping a bearing rail with a clean, lint-free wipe and ensuring that there is clean, wetted grease present.

Harsh environment, short travel, vertically oriented, and high duty cycle applications require more frequent re-lubrication and inspection. Contact an Applications Engineer to discuss your application for more specific recommendations.

Short travel can cause an insufficient distribution of lubricant amongst the rolling elements of the bearing system. For recirculating bearing guide types, short travel is equal to or less than the length of the carriage. For crossed-roller bearing guide types, short travel is equal to or less than twice the spacing of the rolling elements (typically 5-6 mm). If your application is considered short travel, it is recommended to

occasionally drive the stage throughout its full travel range to maintain an even lubrication film over the entire guide surface. More frequent re-lubrication and inspection may be required in these applications.

For longest lubrication intervals, we recommend lubricating guides with Klüberplex BEM 34-132 grease. All guides come pre-lubricated and are ready to go out of the box.

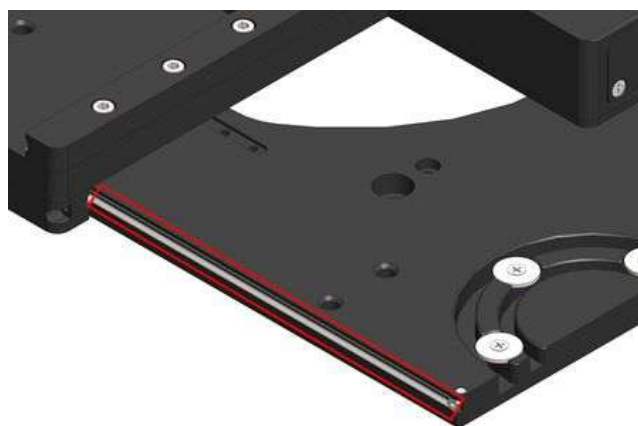
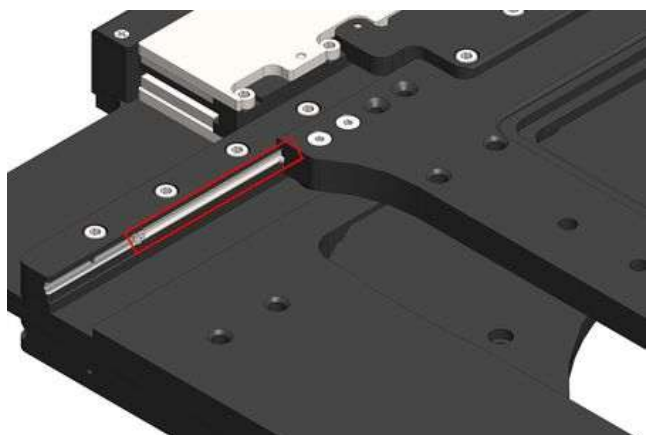

1. **Remove power** to the device before attempting to lubricate.
2. Manually move the stage to a travel limit to expose the linear guides.
3. Using a lint free cloth, wipe away any old grease and debris on the v-channels of the guides. Wipe towards the outside of the stage so debris is not pushed into the roller bearings.
4. Apply a thin strip of lubricant over the entire exposed length of the v-channels with a syringe.
5. Manually move the stage to the opposite travel limit and repeat steps 3 and 4 on the opposite side.
6. Manually move the stage throughout its full travel range a few times to evenly distribute the lubricant.

Perform this procedure on both the lower and upper axes.

## Noise Emissions

The A-weighted emission sound pressure level (SPL) of this device does not exceed 70 dB(A) during intended use.

## Conventions used throughout this document

- Fixed width type indicates communication to and from a device. The ↵ symbol indicates a carriage return, which can be achieved by pressing enter when using a terminal program.

## Quick Tutorial

We recommend using [Zaber Launcher](#) to communicate with the device(s). For other software options, see the [Software](#) page. Please refer to the [Protocol Manual](#) for more detailed information on the available commands.

## Initial Set-up



- Daisy chain all integrated devices and controllers together using the RS-232 "Prev" and "Next" connectors (see [Daisy-Chaining Devices](#) for more details).
- Next, supply power to one or more devices. Many products share power through the daisy-chain cables. The green power indicator on each should light up.
- Turn the knob to move a positioner. Most positioners will only move in one direction until they reach a home sensor at one limit of travel. Then they will move in both directions over full travel.
- Download and install [Zaber Launcher](#). Start Zaber Launcher.
- Create a New Connection and select the communications port the first controller is connected to. For instructions on how to find the available communication ports on your system, please refer to: [Appendix A - Available Communications Ports](#).
- If multiple devices are detected and there are conflicting device numbers, Zaber Launcher will renumber them or you can [renumber](#) them as desired. The first device in the chain (closest to the computer) will become Device 1, the next will become Device 2, and so on.

## Initialization

Every time the device is powered up or reset, you should return the positioner to the home position. This is achieved by sending the [home](#) command to the individual device or all devices. Until this is done, most positioners will only allow motion in one direction, towards the sensor.

## Using the Device

Several commonly used ASCII commands are shown below. For a full list of available commands, please refer to the [Protocol Manual](#).

Command	Description
/1 1 get <a href="#">pos</a> ↵	Query the current position of Device #1 Axis #1.
/1 1 <a href="#">move_abs</a> 10000 ↵	Move Device #1, Axis #1 to position 10000 encoder counts.
/2 1 <a href="#">move_rel</a> -12800 ↵	Move Device #2, Axis #1 in the negative direction by 12800 encoder counts.
/1 <a href="#">stop</a> ↵	Decelerate and stop ALL axes on Device 1. An axis number of 0 or no axis number implies all axes on the device, or the device itself.
/ <a href="#">move_vel</a> 153600 ↵	Move ALL devices and ALL axes in the positive direction at the speed 153600. A device address of 0 or no device address implies all devices in the chain.

## Modifying Device Settings

Here are some examples if you would like to customize particular device or axis settings. Refer to the [Protocol Manual](#) for detailed descriptions of each setting.

Command	Description
/1 set <a href="#">maxspeed</a> 100000 ↵	Set the speed of all axes on the device.
/1 get <a href="#">maxspeed</a> ↵	Query the maximum speed of all axes on the device.
/1 <a href="#">system_restore</a> ↵	Restore all the settings of Device 1 to the default.

## Firmware Upgrades

To allow access to new features and bug fixes, this Zaber device can be upgraded remotely through the Firmware Upgrade app in Zaber Launcher. In the "My Connections" window, click on the "... " menu to the right of the device and select "Firmware Upgrade".

## Device Overview

### Connectors

All images are shown looking into the device.

#### Power

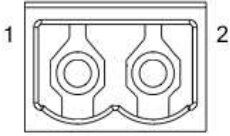
	Pin	Description
	1	24 - 48 V
	2	Device GND

**Note:** This product requires a CE/UL approved AC/DC power converter such as Zaber's PS13S, PS14S or PS15S with a DC cord of at most 3 m.

**Note:** As of February 2022, the power supplies Zaber provides are isolated and thus the device is not connected to Earth ground. Prior to 2022, most power supplies were non-isolated. Isolated units can be distinguished by the "S" suffix in their Zaber part number (eg. PS14S), which is marked on the label on the bottom of the power supply.

#### RS-232 Communications

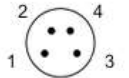
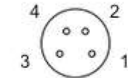
		Pin	Previous	Next
		1	Power (max 4 A)	Power (max 4 A)
		2	Ground	Ground
		3	Receive	Transmit
		4	Transmit	Receive

#### Default Settings

- Baud rate: 115200
- Protocol: Zaber ASCII

#### Specifications

- Supported Protocols: Zaber ASCII
- Supported baud rates: 9600, 19200, 38400, 57600, 115200
- Bits: 8
- Parity: None
- Stop Bits: 1
- Flow Control: None

#### D12 IO pinout

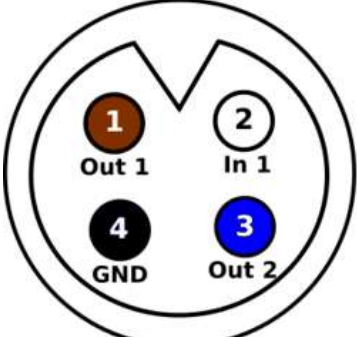
	Pin	Description
	1	Output #1
	2	Input #1
	3	Output #2
	4	Ground

**Note:** See [I/O Usage and Examples](#) for additional information.

**Note:** Any cables connected to the I/O port should be limited to 3 m in length.

#### Other Connectors

For any connections not described in this document, cables should be limited to a length of 3 m.

## Indicators

### Green (Device) - Power

- On: Controller is operational.
- Blinking twice per second: The power supply voltage or controller temperature is out of range.

### Red (Device) - System Error

- On/blinking: An error has occurred. Please contact [Zaber Technical Support](#).

### Yellow (Device) - Communication

- On: Data is being transferred.
- Blinking twice per second: Packet corruption has occurred for ASCII commands sent with a checksum.

### Yellow (Axis) - Axis Status

- On: Axis is moving.

### Blue (Axis) - Warning/Error

- Blinking twice per second: Driver is disabled due to over-temperature, out-of-range voltage or other driver fault; or due to user request. See [Fx Warning Flags](#). *Note: This may occur for a few seconds on power-up as device initializes.*
- Blinking once every 2 seconds: The axis has stalled and stopped.
- Flashes: The stationary axis has been forced out of position (2 short flashes every 1 second), or the encoder has encountered a read error and raised the [FQ warning flag](#) (5 short flashes every 2 seconds).

## Installation

The X-ADR-AE can be connected to a computer as follows:

- Plug the M8 to USB adaptor ([X-USBDC](#)) into one of your computer's USB ports, then attach the device to the adaptor. You may need to use a cable extension to reach your computer. There is no need to power down or reboot the computer.
- Connect the power plug of your power supply to the power connector of the device. The green LED should light up indicating the device has power.
- Additional devices can simply be daisy-chained to the first. See [Daisy-Chaining Devices](#) below.
- Install software from the [Software](#) page. For the initial setup, using [Zaber Launcher](#) is recommended.



As a simple first test, try entering:

```
/renumber ↵  
/1 home ↵  
/1 move rel 10000 ↵
```

The parameter of 10000 in the move command above specifies 10000 encoder counts. To see the encoder count size (default resolution) for the positioner and how it translates to displacement, first go to the [product overview](#) page, find your product, click through to the product's webpage, and click on the "Series Specs" tab. The encoder count size (default resolution) will be shown in the list of product specs either in the "Group Specifications" section or the "Comparison" section.

## Daisy-Chaining Devices

Multiple devices can be connected together in a chain through the Prev and Next connectors. This allows any number of devices to be controlled from a single connection to a computer, reducing cabling demands. In addition, X-Series devices carry power through the daisy chain, so in most cases a power supply only needs to be connected to one device in the chain. Whenever a device is added or removed from a chain, a

[renumber](#) command should be sent to prevent device address conflicts. If there are device address conflicts, Zaber Launcher will renumber automatically the next time you use it to connect to the chain.

**Note:** Daisy-chaining devices with cable lengths exceeding 8 m (25 ft) is not recommended.



## Moving Controller Considerations

The controller of X-ADR-AE stages moves during normal operation. Standard Zaber power supply cables are not flex rated. For this reason, it is highly recommended to supply power to X-ADR-AE stages via the data cable with locking M8 connector. A special power injection box, the X-PIB, is required.

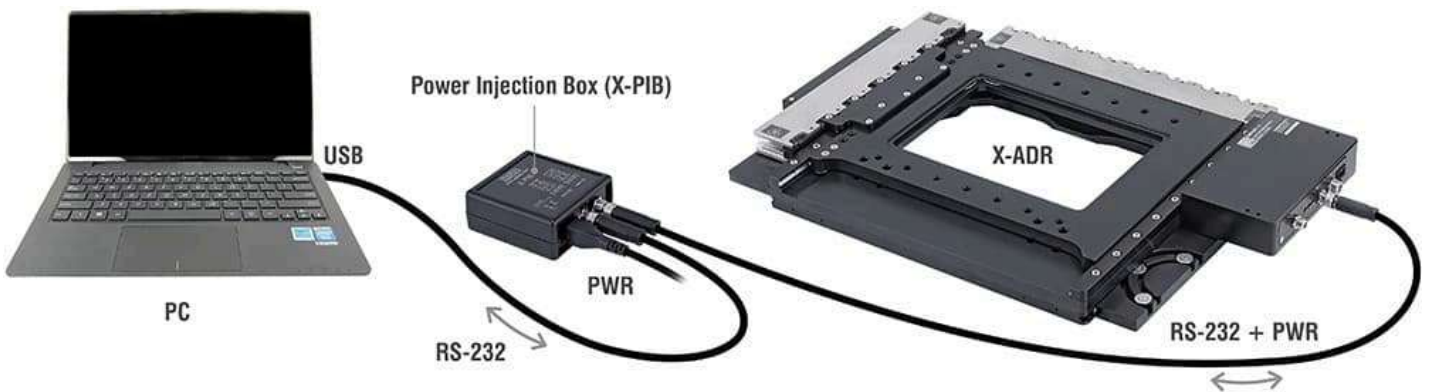

## Physical Installation

### Shipping Hardware

Both axes of the X-ADR-AE stage are locked in place for shipping using two cable ties. These must be cut and removed prior to powering up the device.

💡 **Important:** If the stage needs to be shipped elsewhere, two new cable ties (0.14" wide x 0.05" thick) must be installed to secure the axes prior to shipping. Shipping the stage without the axes secured will result in damage.

■

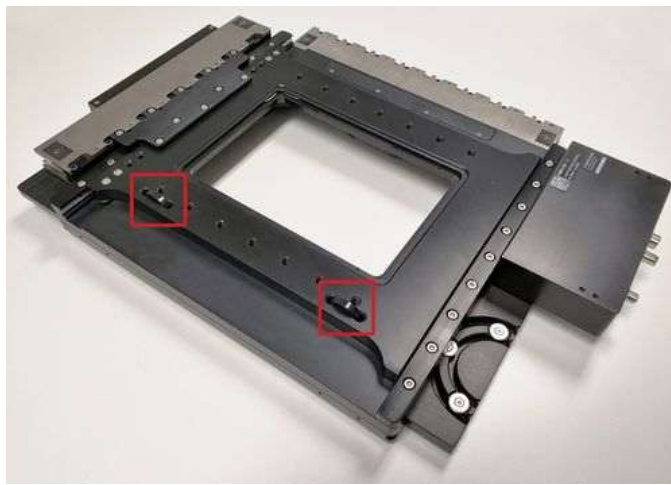

The highlighted cable ties need to be cut and removed prior to powering up the device.

💡 **Tip:** The [AP267 shipping plate](#) accessory provides added protection against damage during shipping. It is highly recommended to use this accessory instead of cable ties for stages that are to be transported repeatedly. The plate must be installed prior to shipping the stage as shown below.

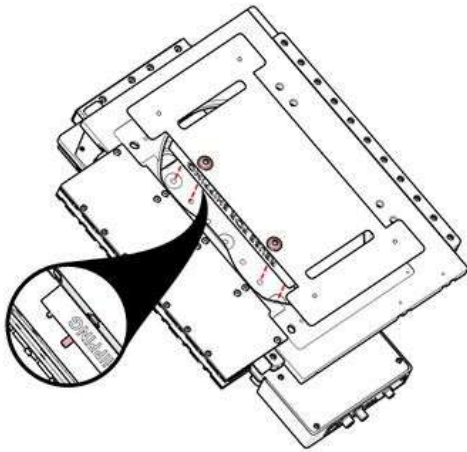

1. Place the X-ADR-AE upside down and align it such that you can see the M6 mounting holes on the top plate through the aperture. Align pins on the red spacer with the outer M6 screw holes.

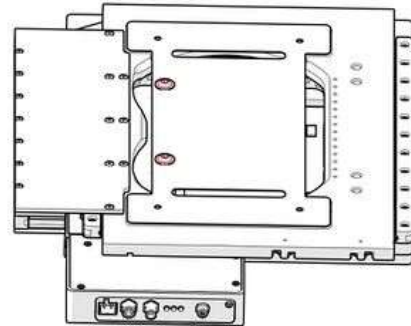

2. Use a 4 mm hex key to fasten the two M6 screws.

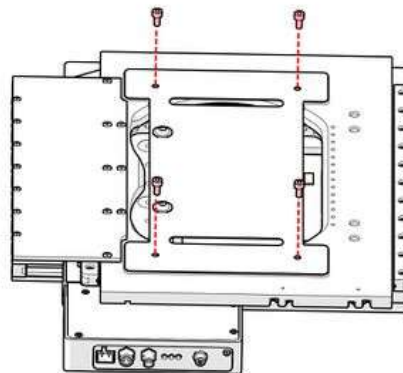

3. Use a 3 mm hex key to fasten the four M4 screws.

## Mounting

💡 **Tip:** To obtain the best pitch, roll, yaw and runout performance, mount the stage to a known flat, stiff surface. Our tests were performed on a granite surface plate, grade A flatness.

**⚠ Stability Hazard!** Ensure the stage is fastened to a secure surface before mounting a load on the carriage. Ensure loads are mounted securely to the carriage of the stage before operating.

**⚠ Mounting and Maintenance Hazard!** For operator safety, the X-ADR-AE should always be un-powered during all cleaning, maintenance, and stage or load mounting operations. A powered stage could exert high forces and move at high speeds very suddenly if accidentally given a move command.

**⚠ Pinch Hazard!** X-ADR-AE stages can create pinch hazards between the upper-axis and lower-axis. Make sure to keep hands clear when powering up the stages.



1a. **Two piece adaptor plates:** Flip the stage upside down. Secure each mounting adaptor to the stage using 2 M4 x 08mm socket cap screws.

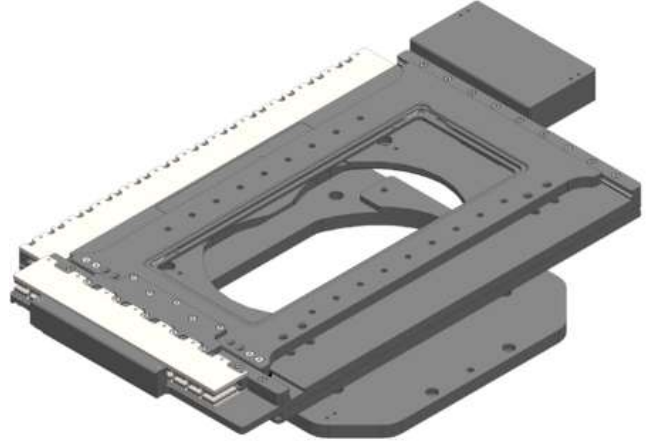

1b. **Single piece adaptor plates:** Lower the stage onto its mounting adaptor. Make sure the pockets on the stage's base fit into the raised bosses of the adaptor. The device should not be able to slide horizontally when sitting properly on the adaptor bosses.

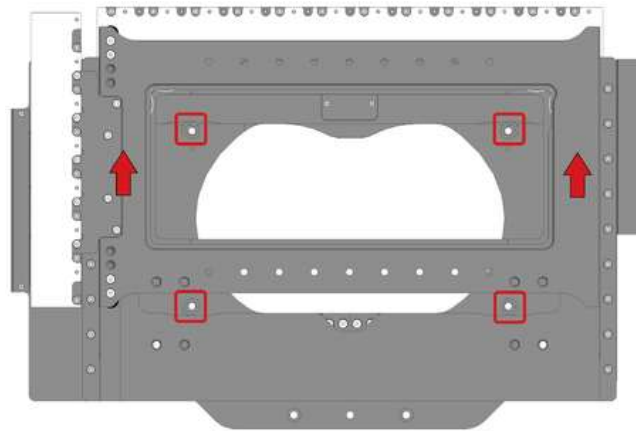

2. Manually move the stage's axes to expose the mounting holes on the base.

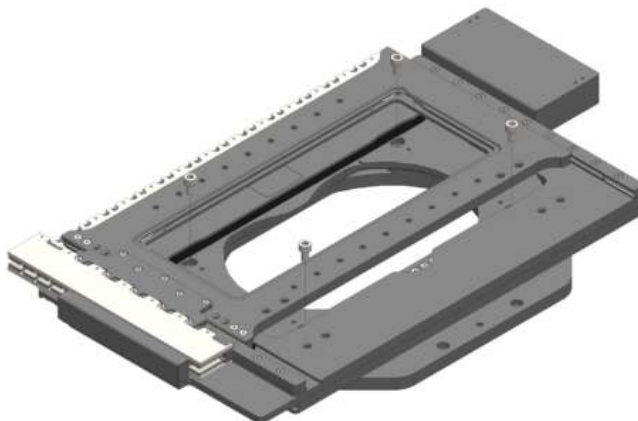

3. Secure the stage using 4 M6 socket cap screws, 10mm or longer.

## Cable Management

X-ADR-AE stages feature an integrated cable management system for the power/data and IO cables. To maximize cable lifetime it is recommended to use this system for typical operation.

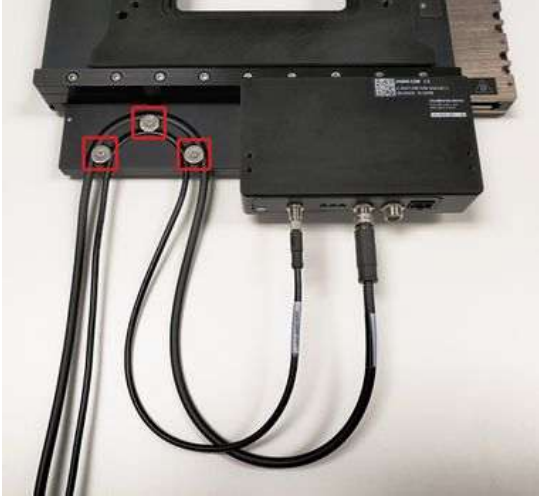

1. Remove the 3 washers shown with a Phillips screwdriver. Insert the cables into each slot, then reattach all 3 washers. Connect the cables to the stage's controller.

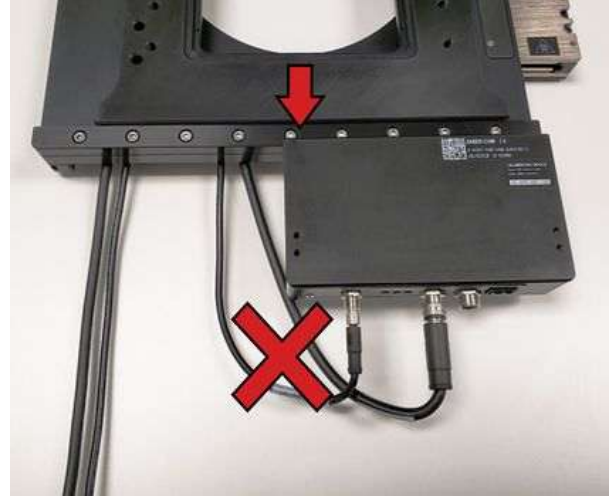

2. Manually ensure the lower axis can move through its full travel range without kinking or straining the cables before powering up the device. If the cables don't have enough slack (shown above), loosen off the washers and add more slack to the cables.

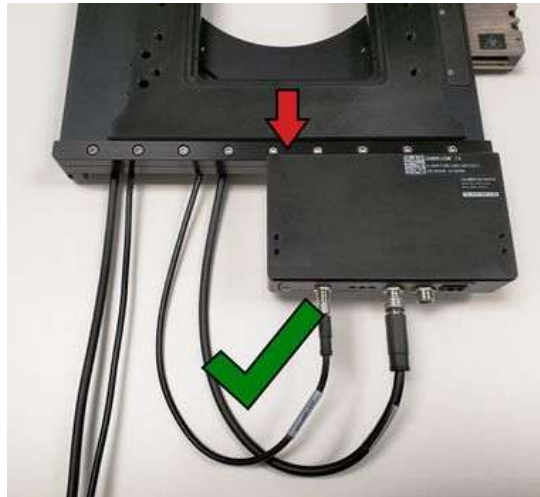

Here is an example of cables with a suitable amount of slack. An adequate bend radius is maintained at both limits of travel.

AP233 and AP234 mounting adaptor plates include holes that allow mounting [CG01](#) or [CG02](#) cable guides between the adaptor plate and stage. These cable guides can be used as an alternative for the power/data and IO cable management, or as management for additional user specific cabling.

A specific number of cable guide links is required for each stage travel.

CG01/CG02 Cable Guide Link Requirements	
Stage Model	Number of links
ADR130B100B	16
ADR250B100B	19

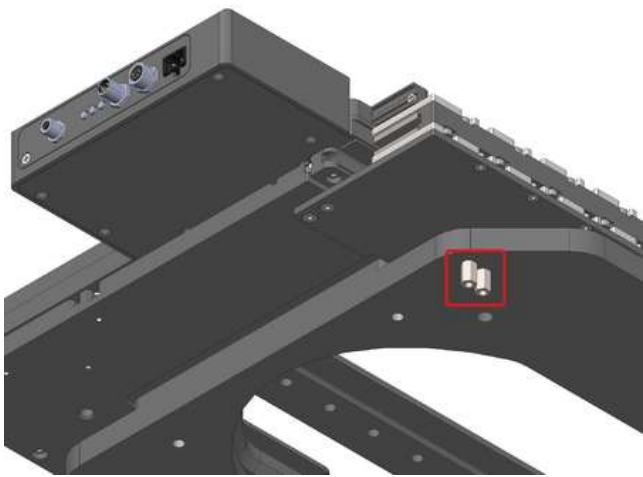

1. With a 6mm wrench, attach the M3 standoffs to the bottom of the adaptor plate.

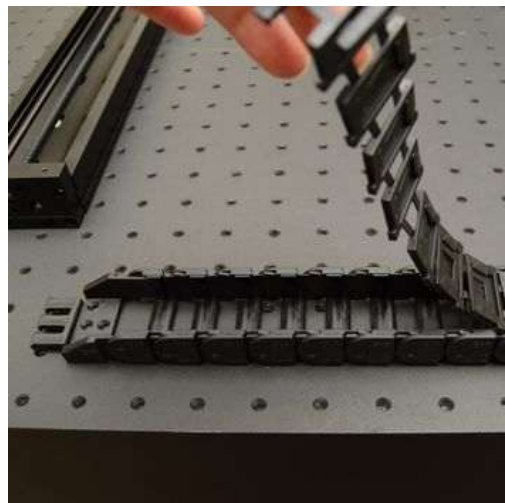

2. Peel open the cable guide.

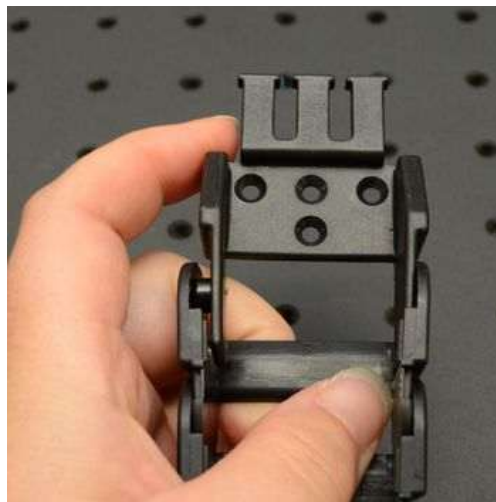

3. Attach the CGxxT parts to the mating ends of the CGxx.

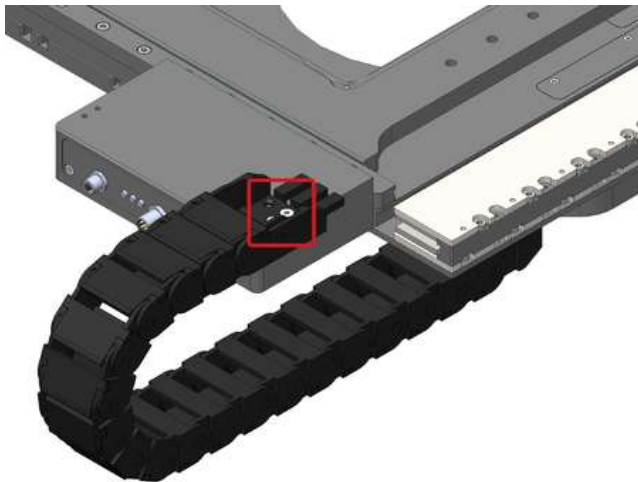

4. Attach one termination of the cable guide to the stage's controller housing using two M3 flathead screws and a 2 mm hex key.

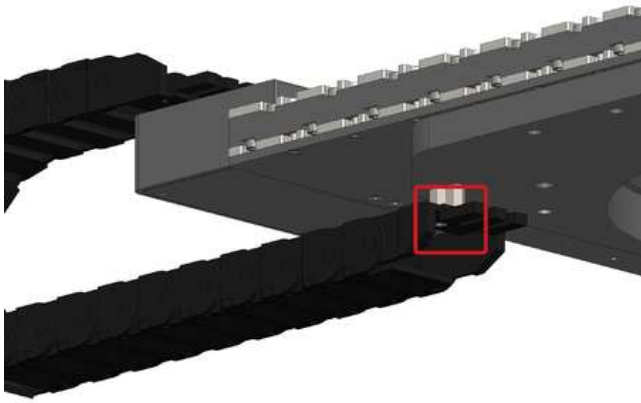

5. Attach the other termination of the cable guide to the M3 standoffs using two M3 flathead screws and a 2 mm hex key.

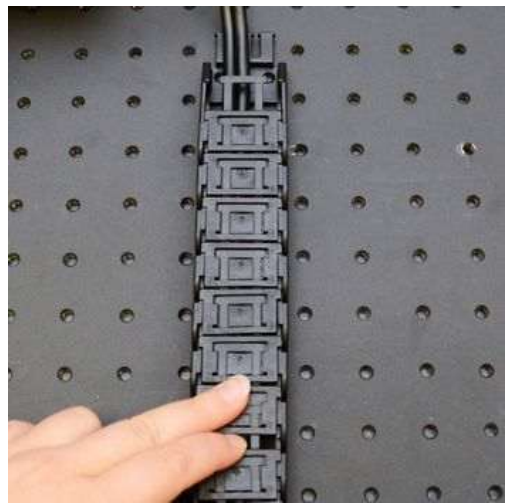

6. Install desired cables. Close the CGxx cable guide by clicking the parts together. **Note:** The CGxx cable guide parts must be oriented as shown to click together.

## Encoder Scale Protection

X-ADR-AE stages with 250mm lower axis travel include an optional cover that assists in protecting the lower axis encoder scale from contamination. This cover is stored on the bottom stage of the stage for shipping. To install the cover:

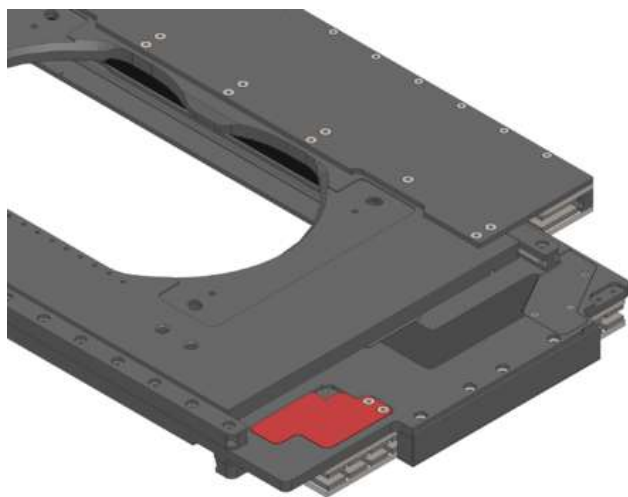

1. Move the lower axis by hand until the cover is visible on the bottom of the stage's middle plate. Remove the 2 M3 screws with a 2 mm hex key.

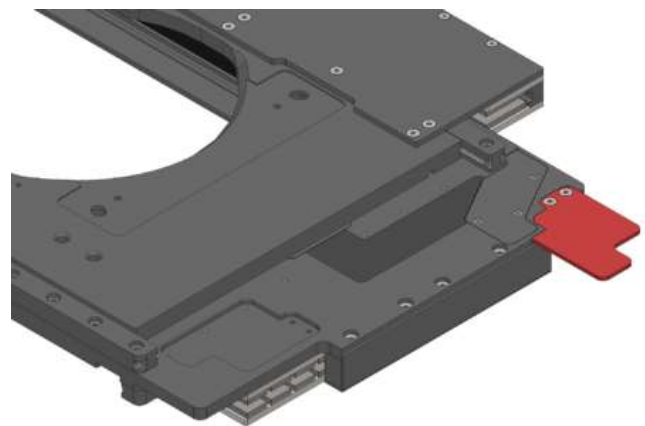

2. Reinstall the cover as shown with the same 2 M3 screws.

## Operation

### ADR Inserts

X-ADR-AE stages accept the following size inserts:

Stage	Insert size
ADR130B100B	160 x 110 mm
ADR250B100B	283 x 110 mm

The following inserts are currently available:

ADR130B100B	ADR250B100B
AM108 - for holding various petri dishes or microscope slides	AM227 - Allows compatibility with 160 x 110 mm inserts
AM109 - for holding a single SLAS standard microplate	AM228 - solid aluminum insert

AM126 - M6 x 25 mm breadboard	AM229 - M6 x 25 mm breadboard
	AM230 - for holding up to 2 SLAS standard microplates
	AM231 - for holding up to 8, 25 x 75 mm microscope slides

For more details about these inserts, please see our [accessory page](#). Zaber can also provide custom inserts on request.

Conventionally, inserts are held in place by a pair of spring clips in two corners of the ADR aperture. To install an insert, place the one edge up against the springs first. While holding this side down, push the insert towards the spring clip and snap the opposing edge into place. Removal is the reverse of this procedure.

For most applications, the spring clips should provide sufficient force to hold the insert in place, while still allowing quick changes between inserts. For applications requiring more secure mounting, custom inserts can be provided that can be secured to the ADR using 4 M2 screws.

For systems requiring very fast or automated insert changes, X-ADR-AE stages also have a magnetic constraint system to hold inserts in place. An insert with magnets placed at the correct positions will automatically snap into place when lowered into the stage's aperture. The insert can be removed from the stage by pulling straight up.

If desired, both spring clips can be removed from the ADR. This can be performed by flipping the stage upside down, removing the indicated M2.5 screws, and then pulling out each spring clip from its respective slot. To reinstall the spring clips, place each clip into its respective slot, install an insert into the ADR aperture to compress the springs, then reinstall the M2.5 screws.

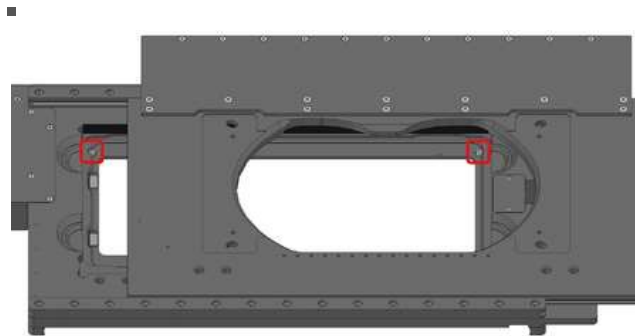

Removing these M2.5 screws allows for removal or installation of the spring clips.

## Setting Travel Limits

X-ADR-AE stages feature adjustable positive and negative bump stops on each axis, allowing the physical axis travel range to be restricted. While the travel range can also be reduced via soft limits in firmware, the stage may travel outside of these soft limits during homing. The homing routine moves in the negative direction until either the index mark is located at the center of travel, or the negative bump stop is encountered. Therefore, to decrease the travel range of the device under all operating conditions, it is recommended to adjust the bump stops accordingly.

Bump stop adjustment is performed by removing the two M3 screws attaching the stop bracket, sliding the stop bracket inwards or outwards, and then reinstalling the screws. Each bracket sits in a slot to maintain alignment while the screws are removed.

**Tip:** It is recommended to torque the bump stop screws to 0.8 Nm after installation.

**Warning:** Handle the stage with care while adjusting the bump stops. Crashing the stage into the end of travel with a bump stop removed can damage the bearings.

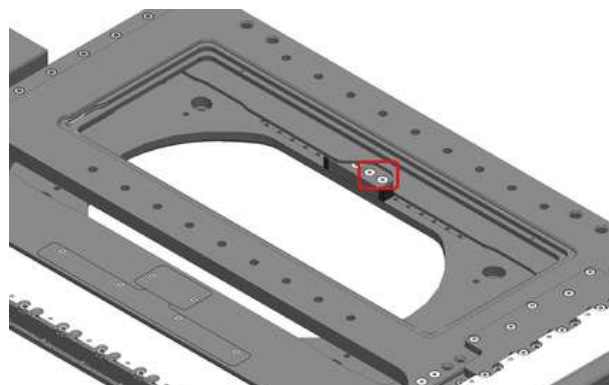

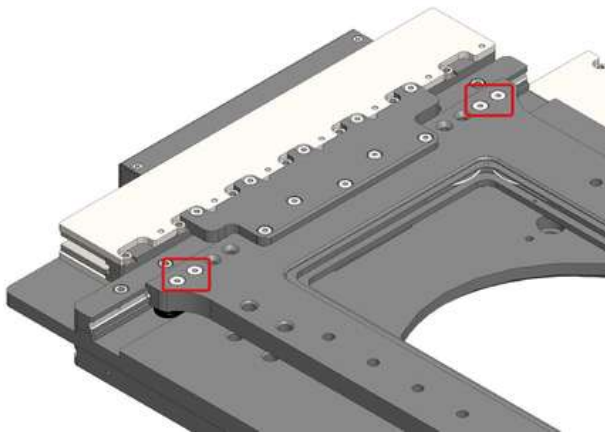

Upper-axis bump stop screws. Moving each upper axis stop one screw pattern inwards will decrease the travel limit by 10mm.

Lower-axis bump stop screws. Moving each bump stop one screw pattern outwards will decrease the travel limit by 10mm. Manually move both axes to expose the bump stop mounting screws.

The upper-axis bump stops are eccentric, allowing each travel limit to be adjusted in finer 5 mm increments. This adjustment is performed by completely removing the stop bracket from its alignment slot and reinstalling the bracket facing the opposite direction. It may be required to completely remove both brackets at the same time in order to get access.



This bump stop has the long end pointing inwards. Flipping it will increase the travel limit by 5 mm.

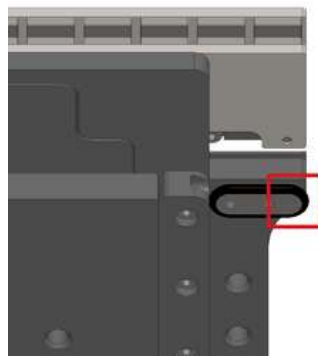

This bump stop has the long end pointing outwards. Flipping it will decrease the travel limit by 5 mm.

**Important:** After adjusting the bump stops, it is important to set the soft travel limits in firmware. Use the [tools findrange hardstop](#) command on each axis to automatically measure and save the new travel limits. It is recommended to append the "save" option to the [tools findrange hardstop](#) command so new travel limits persist across a reset or power-up.

## Trajectory Control and Behaviour

This section describes the behaviour of the axis trajectory when a movement command is issued.

### Software Position Limits

The travel range of the axis is limited by the Minimum Position and Maximum Position settings. The factory settings for the axis are configured to match the physical travel range. If a customized range is desired, it can be changed by configuring the [limit.min](#) and [limit.max](#) settings to appropriate values. For the Current Position, query [pos](#).

#### Minimum Position

When the Current Position is less than the Minimum Position value, the axis cannot move in the negative direction.

#### Maximum Position

When the Current Position is greater than the Maximum Position value, the axis cannot move in the positive direction.

### Movement Speed

The movement speed of the axis depends on axis status and various speed settings. If the axis has not been initialized by the [home](#) command or by moving towards the home end of the axis, movement speed will be constrained to fail-safe values. The home status of the axis can be determined by reading the [limit.home.triggered](#) setting.

Movement speed of the axis is specified below:

[move vel](#)

The axis will move at the specified speed regardless of home status.

#### Other movement commands - when the axis has not been homed

The axis will move at the slower of the [maxspeed](#) and [limit\\_approach\\_maxspeed](#) settings.

#### Other movement commands - when the axis has been homed

The axis will move at the speed specified by the [maxspeed](#) setting.

### Servo Tuning

This positioner is a closed-loop positioning servo system. It continuously monitors and corrects its position via the linear encoder. As with any servo system, the behaviour is dependent on the controller tuning. It comes pre-tuned out of the box with settings that are optimized for regular use under a light load. However, as with any closed-loop feedback system, the performance is load-dependent, and conditions significantly outside of the intended operating range have the potential for reduced performance or instability. Thus, if operation with large or unconventional dynamic loads is desired, or if the application demands specific performance characteristics, it may be necessary to tune the servo parameters. This may be conveniently done by using Zaber Launcher's Servo Tuner App, or [Zaber Motion Library's](#) ServoTuner API

**Tip:** Because servo positioners continuously monitor and correct position, it is necessary to specify how accurate and stable the final position must be at the end of the movement. Criteria required for the controller to report IDLE status after movement are specified using the [cloop.settle.tolerance](#) and [cloop.settle.period](#) settings. For applications requiring utmost precision, you may want to specify a smaller tolerance and longer period. Note that there is a direct, inverse relationship between settling time and [cloop.settle.tolerance](#), and the controller may never report IDLE status if the tolerance is too small.

### I/O Usage and Examples

The X-ADR-AE features one digital input and two digital outputs that operate on a +5 V supply and are TTL compatible. The input and output capabilities of the X-ADR-AE can also be used with [triggers](#) to perform actions based on the current value of the I/O channel.

#### Digital Inputs

The input will draw up to 1 mA during operation.

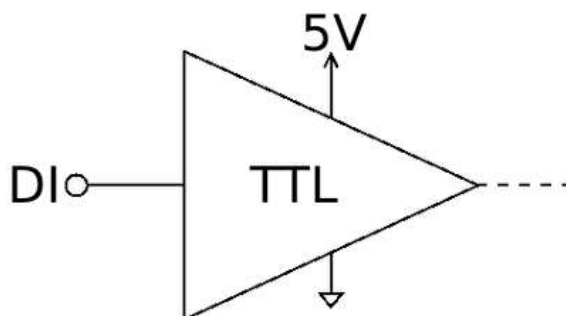

Reading the input is accomplished by sending the unit an [io\\_get\\_di](#) command, as shown below.

```
/1 io get di 1\r\n@01 0 OK IDLE -- 0
```

This command queries the input on the device, in this case input 1, which is low.

#### Digital Outputs

The digital outputs use an open collector buffer with a pre-installed 1 kΩ pull up resistor to +5 V. Each output can sink up to 20 mA.

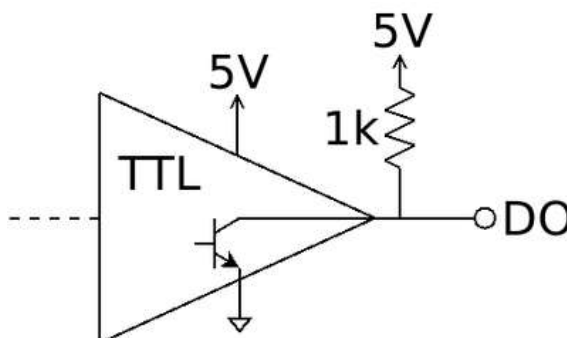

The digital outputs are set through the [io\\_set\\_do](#) command, as shown below.

```
/1 io set do 2 1↵
@01 0 OK IDLE -- 0
/1 io set do 1 0↵
@01 0 OK IDLE -- 0
```

The first command sets the second digital output high (5 V). The second command sets the first digital output low (0 V).

## Troubleshooting X-Series Motion Devices

The following sections contain tips for troubleshooting common problems.

### Front Panel Indicators

#### Green LED on.

The device is powered on and is operating normally.

#### Green LED flashes slowly.

The operating conditions of the device are outside of the recommended range.

This will occur when the supply voltage is either over or under the recommended range or the controller temperature has exceeded the set limit. Check the following:

- The input voltage is within the operational range of the device. This can be read from the device with the [get\\_system.voltage](#) command.
- The device temperature is within range. This can be read from the device with the [get\\_system.temperature](#) command.

#### Green LED off.

The device is not powered.

Check the supply connections and power adaptor for correct operation.

#### Red LED on or flashing.

A critical error has occurred.

Please contact [Zaber Technical Support](#).

#### Yellow LED always off or flashes but no reply.

There are communication errors.

Please see the [Communication Errors](#) section below.

#### Blue LED flashing during a move or blinking every two seconds.

The axis has slipped or stalled.

Please see the [Slipping and Stalling](#) section below.

#### Blue LED showing a burst of 2 flashes every 1 second.

A stationary axis has been forced out of position.

#### Blue LED showing a burst of 5 flashes every 2 seconds.

The encoder has encountered a read error.

Please contact [Zaber Technical Support](#).

#### Blue LED blinking twice per second. Axis does not move.

Driver may be disabled due to over-temperature, out-of-range voltage or other driver fault; or due to user request.

See [Fx Warning Flags](#).

Once the issue has been resolved, send [driver.enable](#).

## Unexpected Behaviour

#### The axis doesn't respond to a move command.

The axis may need to be homed before use.

Send the [home](#) command.

#### The axis is moving on its own and running against the ends of travel.

The position encoder has de-synchronized.

Reset the device by power cycling it or sending the [system.reset](#) command, then re-initialize it with the [home](#) command.

#### The axis is moving very slowly. It used to move faster.

The speed settings may have been changed inadvertently.

Send a [system.restore](#) command.

#### The axis makes minor static-sounding noises even when stationary.

This condition happens if the closed-loop position controller is set to an aggressive servo tuning. It does not have an impact on the performance or lifetime of the stage, and is usually a normal operating condition.

Audible noise may be reduced or eliminated by lowering the servo gain. If the noise is very loud, then the gain needs to be reduced.

See the instructions on servo tuning.

**The axis oscillates and has difficulty maintaining a fixed position.**

The servo tuning may have been set incorrectly, or adjusted for a different load than what the axis is operating with.

See the instructions on servo tuning.

**The axis consistently overshoots the target position position an unacceptable amount.**

The acceleration setting may be too high for the load mass on the stage, or the servo tuning may be set inappropriately.

See the instructions on servo tuning.

**The axis moves freely by hand and does not hold its position.**

A setting might have been inadvertently changed.

- Try sending the [system reset](#) command.

**The positioner's motor unexpectedly shuts off. An **Fx warning flag** is present.**

The motor over-temperature protection switch has been tripped. This sensor will trip if the positioner's maximum continuous thrust specification is exceeded for too long. To prevent this condition from occurring again, reduce the average force that the motor outputs by reducing acceleration, reducing the load, or lowering the duty cycle.

Send a [driver enable](#) command. The axis does not require homing.

## Communication Errors

**There is no communication with the device; the Yellow LED does not come on or flash.**

There are several things that should be checked:

- Make sure the correct serial port is selected. Try selecting other serial ports in the software.
- Check the baud rate, hand shaking, parity, stop bit, etc. when configuring the serial communications software. The required settings are listed in the [RS-232 Communications](#) section above.
- Make sure there are no bent pins in the ends of all the data cables
- Make sure the device is powered. The Green LED should be on.
- If the computer is a laptop running on batteries, try plugging in the power. Some laptops disable the serial ports when running on batteries.
- Make sure a null modem adaptor or cable is not being used.
- Make sure the correct adaptors (if any) are being used. Refer to the pinouts in the [RS-232 Communications](#) section above.
- If the problem was encountered when trying to control the device with custom software, try using [Zaber Launcher](#) to verify that the hardware is functioning properly.

**Two or more devices both respond to commands sent to device 1.**

Most devices are shipped with their device number set as 1. If you connect to the devices with Zaber Launcher, it will automatically renumber them if needed. If you aren't able to install and open Zaber Launcher, send the [renumber](#) command in the software you are using to set all of the device numbers to different values.

**The Yellow LED comes on briefly when sending a command, but the axis does not move and does not reply.**

Check baud rate, hand shaking, parity, stop bit, etc. are set as per the [RS-232 Communications](#) defaults.

The device numbers may not be what is expected, issue a [renumber](#) command. Make sure that the computer does not transmit anything else while the devices renumber.

## Slipping and Stalling

**The axis moves smoothly, but only moves for a short time then stops. The Blue LED is flashing but the axis is not actually slipping or stalling.**

The internal encoder counter needs to be re-initialized. Reset the device by power cycling it or sending [system reset](#) command, then re-initialize it with the [home](#) command.

Ground the device and avoid operating it under statically noisy environment.

**The axis makes noise but does not move. The Blue LED is flashing.**

The axis is stalling.

Try removing all external loads. If the axis now extends and retracts normally, the problem is excessive load. Try to reduce the load and ensure the load is less than the maximum thrust. A higher thrust or torque can be achieved by lowering the speed of the axis using the [maxspeed](#) setting.

If an axis is stalling with no external load at default speed and acceleration settings then it requires servicing.

## Warranty and Repair

For Zaber's policies on warranty and repair, please refer to the [Ordering Policies](#).

### Standard products

Standard products are any part numbers that do not contain the suffix ENG followed by a 4 digit number. Most, but not all, standard products are listed for sale on our website. All standard Zaber products are backed by a one-month satisfaction guarantee. If you are not satisfied with your purchase, we will refund your payment minus any shipping charges. Goods must be in brand new saleable condition with no marks. Zaber products are guaranteed for one year. During this period Zaber will repair any products with faults due to manufacturing defects, free of charge.

## Custom products

Custom products are any part numbers containing the suffix ENG followed by a 4 digit number. Each of these products has been designed for a custom application for a particular customer. Custom products are guaranteed for one year, unless explicitly stated otherwise. During this period Zaber will repair any products with faults due to manufacturing defects, free of charge.

## How to return products

Customers with devices in need of return or repair should contact Zaber to obtain an RMA form which must be filled out and sent back to us to receive an RMA number. The RMA form contains instructions for packing and returning the device. The specified RMA number must be included on the shipment to ensure timely processing.

## Email Updates

If you would like to receive our periodic email newsletter including product updates and promotions.

## Contact Information

Contact Zaber Technologies Inc by any of the following methods:

<b>Phone</b>	1-604-569-3780 (direct) 1-888-276-8033 (toll free in North America)
<b>Fax</b>	1-604-648-8033
<b>Mail</b>	#2 - 605 West Kent Ave. N., Vancouver, British Columbia, Canada, V6P 6T7
<b>Web</b>	<a href="http://www.zaber.com">www.zaber.com</a>
<b>Email</b>	Please visit our website for up to date email contact information.

The original instructions for this product are available at <https://www.zaber.com/manuals/X-ADR-AE>.

## Appendix A - Available Communications Ports

The following instructions outline how to find installed serial ports on your computer.

### Windows

- Open Search or Run from the Start Menu or Taskbar, type "Device Manager" and press enter.



- Expand the Ports (COM & LPT) category.

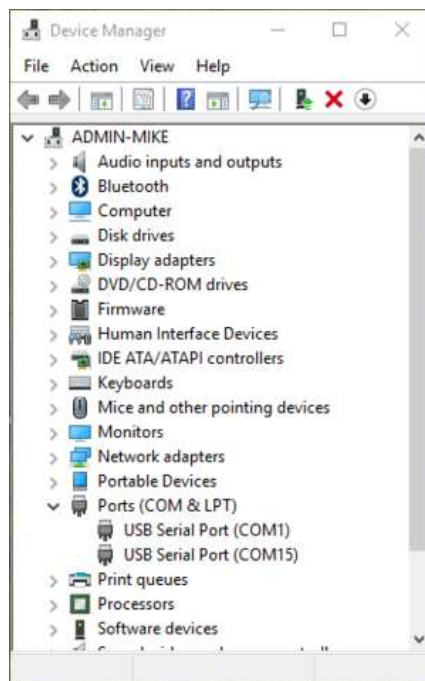

- In this example there are two serial ports available (COM1 and COM15), which are both USB adaptors.

## Linux

- Finding devices
  - Open a terminal and execute the following command:
 

```
dmesg | grep -E ttyU?S
```

    - The response will be similar to the following:
 

```
[ 2.029214] serial8250: ttyS0 at I/O 0x3f8 (irq = 4) is a 16550A
[ 2.432572] 00:07: ttyS0 at I/O 0x3f8 (irq = 4) is a 16550A
[ 2.468149] 0000:00:03.3: ttyS4 at I/O 0xec98 (irq = 17) is a 16550A
[ 13.514432] usb 7-2: FTDI USB Serial Device converter now attached to ttyUSB0
```

      - This shows that there are 3 serial ports available: ttyS0, ttyS4 and ttyUSB0 (a USB adaptor)
  - Checking port permissions
    - Using the ports found above, execute the following command
 

```
ls -l /dev/tty{S0, S4, USB0}
```

      - The permissions, given below, show that a user has to be root or a member of the dialout group to be able to access these devices
 

```
crw-rw---- 1 root dialout 4, 64 Oct 31 06:44 /dev/ttyS0
crw-rw---- 1 root dialout 4, 68 Oct 31 06:45 /dev/ttyS4
crw-rw---- 1 root dialout 188, 0 Oct 31 07:58 /dev/ttyUSB0
```
  - Checking group membership
    - Execute the following command
 

```
groups
```

      - The output will be similar to the following:
 

```
adm cdrom sudo dip plugdev users lpadmin sambashare
```

        - Notice that dialout is not in the list
        - A user can be added to the dialout group with the following command
 

```
sudo adduser $USER dialout
```

          - Group membership will not take effect until the next logon.

## OSX

- Finding devices
  - Open a terminal and execute the following command:
 

```
ls /dev/cu.*serial*
```

    - The response will be similar to the following:
 

```
/dev/cu.usbserial-FTB3QAET
/dev/cu.usbserial-FTEJJ1YW
```

      - This shows that there are two serial ports available, both of which happen to be USB adaptors.

- There may be other devices that match this query, such as keyboards or some web cameras. To determine which one corresponds to your USB serial cable, try repeating the command with and without the cable connected to the computer, to see which one appears and disappears.

## Product Drawings

[Drawing for the X-ADR130B100B-SAE53D12 DWG 3538 R01D](#)

[Drawing for X-ADR250B100B-SAE53D12 DWG 3272 R02D](#)

## Specifications

Specification	Value	Alternate Unit
Built-in Controller	Yes	
Accuracy (unidirectional)	5 $\mu\text{m}$	0.000197"
Repeatability	< 0.5 $\mu\text{m}$	< 0.000020"
Minimum Incremental Move	50 nm	
Maximum Speed	750 mm/s	29.528"/s
Minimum Speed	0.61 nm/s	
Speed Resolution	0.61 nm/s	
Encoder Type	Linear analog encoder	
Encoder Count Size	1 nm	
Peak Thrust	35 N	7.8 lb
Maximum Continuous Thrust	13 N	2.9 lb
Communication Interface	RS-232	
Communication Protocol	Zaber ASCII (Default)	
Data Cable Connection	Locking 4-pin M8	
Maximum Moment (Pitch)	500 N·cm	708.1 oz·in
Maximum Moment (Roll)	500 N·cm	708.1 oz·in
Maximum Moment (Yaw)	500 N·cm	708.1 oz·in
Typical Velocity Stability	$\pm 0.12\%$ at 100 mm/s with a 0.55 kg payload	
Pitch	0.025°	0.436 mrad
Yaw	0.01°	0.174 mrad
Power Supply	24-48 VDC	
Maximum Current Draw	2300 mA	
Motor Type	Moving Magnet Track Linear Motor	
Force Constant	5.5 N/A	1.2 lbs/A
Guide Type	Crossed-Roller Bearing	
Limit or Home Sensing	Optical Index Mark	
Axes of Motion	2	
LED Indicators	Yes	
Mounting Interface	Separate mounting adaptors available	
Digital Input	1	
Digital Output	2	
Operating Temperature Range	0 to 50 °C	
CE Compliant	Yes	
Vacuum Compatible	No	

## Comparison

Part Number	Lower Travel Range	Upper Travel Range	Maximum Centered Load	Roll
<b>X-ADR130B100B-SAE53D12</b>	130 mm (5.118")	100 mm (3.937")	50 N (11.2 lb)	0.006° (0.105 mrad)
<b>X-ADR250B100B-SAE53D12</b>	250 mm (9.843")	100 mm (3.937")	30 N (6.7 lb)	0.01° (0.174 mrad)

Part Number	Lower Moving Mass	Upper Moving Mass	Weight
<b>X-ADR130B100B-SAE53D12</b>	3.3 kg (7.260 lbs)	1.3 kg (2.860 lbs)	4.9 kg (10.803 lb)
<b>X-ADR250B100B-SAE53D12</b>	3.9 kg (8.580 lbs)	1.5 kg (3.300 lbs)	6.2 kg (13.669 lb)

### Typical Accuracy

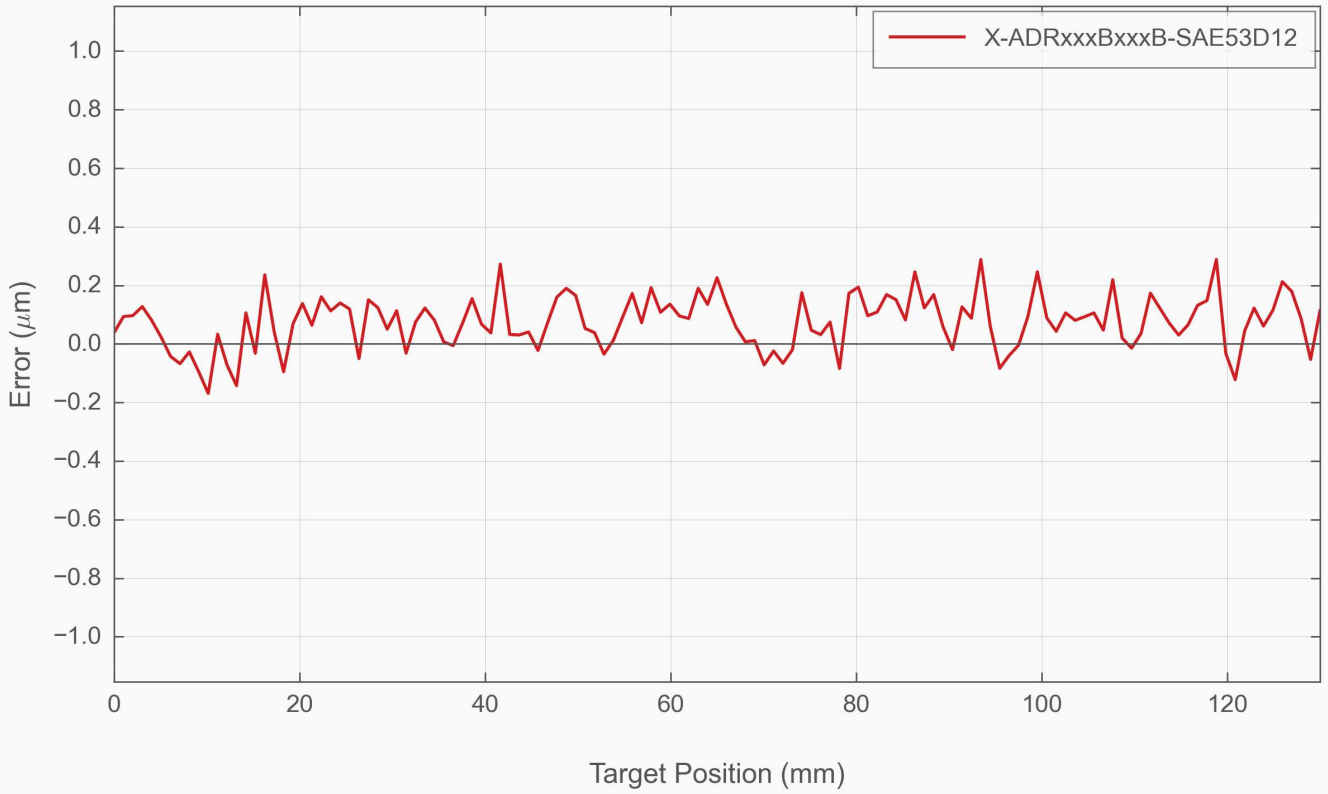

### Typical Minimum Incremental Move

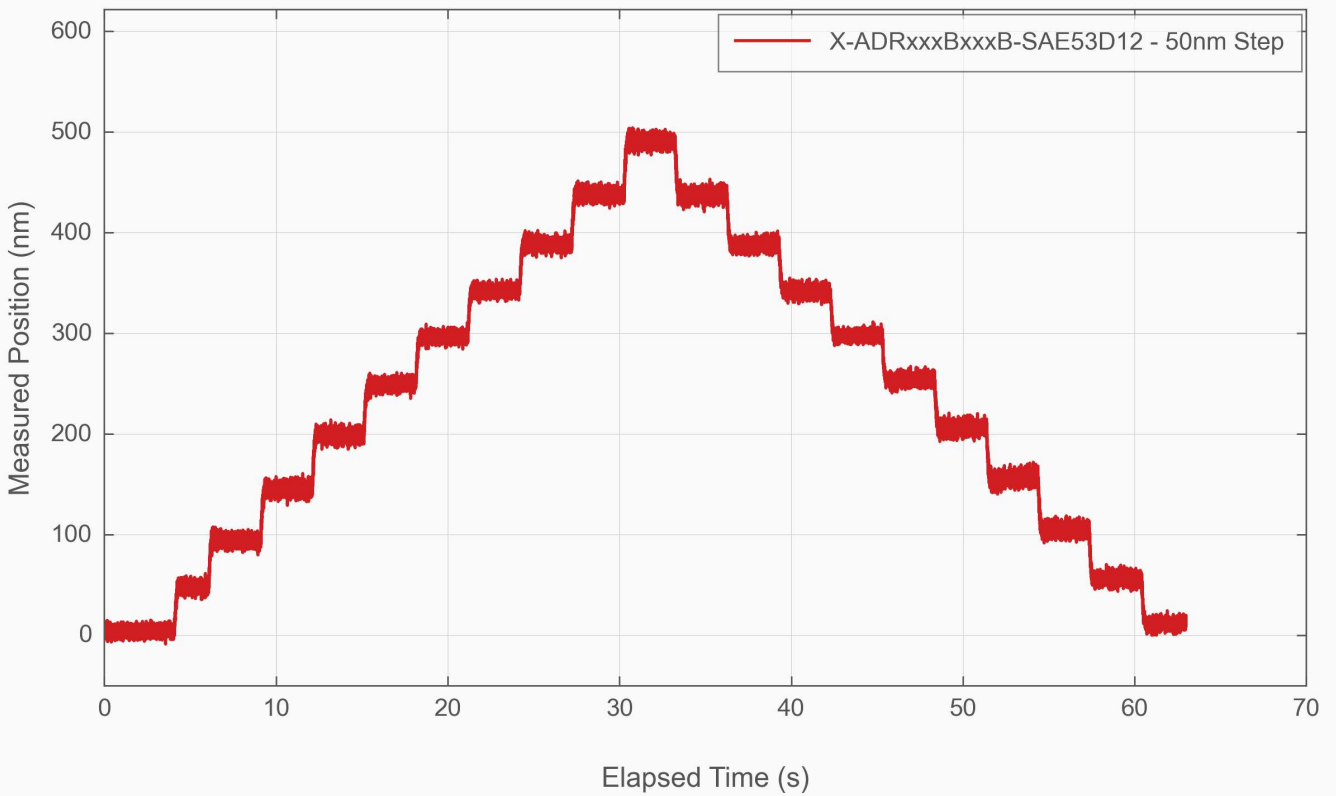

## Typical Velocity Stability and Following Error

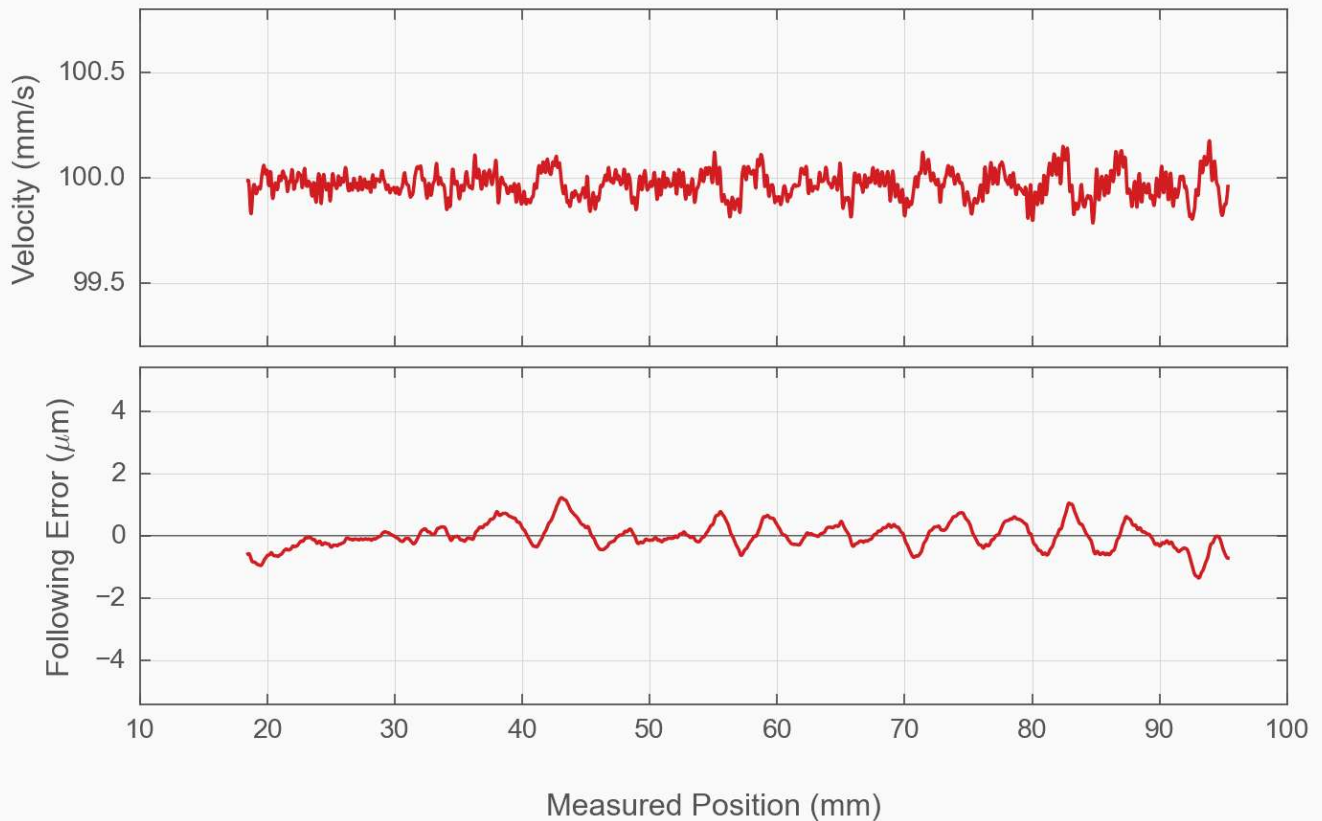

*This product uses the FreeRTOS kernel. FreeRTOS is © 2026 Amazon.com, Inc. or its affiliates and is governed by the following license:*

All rights reserved.

Permission is hereby granted, free of charge, to any person obtaining a copy of this software and associated documentation files (the "Software"), to deal in the Software without restriction, including without limitation the rights to use, copy, modify, merge, publish, distribute, sublicense, and/or sell copies of the Software, and to permit persons to whom the Software is furnished to do so, subject to the following conditions:

The above copyright notice and this permission notice shall be included in all copies or substantial portions of the Software.

THE SOFTWARE IS PROVIDED "AS IS", WITHOUT WARRANTY OF ANY KIND, EXPRESS OR IMPLIED, INCLUDING BUT NOT LIMITED TO THE WARRANTIES OF MERCHANTABILITY, FITNESS FOR A PARTICULAR PURPOSE AND NONINFRINGEMENT.

IN NO EVENT SHALL THE AUTHORS OR COPYRIGHT HOLDERS BE LIABLE FOR ANY CLAIM, DAMAGES OR OTHER LIABILITY, WHETHER IN AN ACTION OF CONTRACT, TORT OR OTHERWISE, ARISING FROM, OUT OF OR IN CONNECTION WITH THE SOFTWARE OR THE USE OR OTHER DEALINGS IN THE SOFTWARE.

*This product uses the LZ4 compression library. LZ4 is © 2011–2016 Yann Collet and is governed by the following license:*

All rights reserved.

Redistribution and use in source and binary forms, with or without modification, are permitted provided that the following conditions are met:

- Redistributions of source code must retain the above copyright notice, this list of conditions and the following disclaimer.
- Redistributions in binary form must reproduce the above copyright notice, this list of conditions and the following disclaimer in the documentation and/or other materials provided with the distribution.

THIS SOFTWARE IS PROVIDED BY THE COPYRIGHT HOLDERS AND CONTRIBUTORS "AS IS" AND ANY EXPRESS OR IMPLIED WARRANTIES, INCLUDING, BUT NOT LIMITED TO, THE IMPLIED WARRANTIES OF MERCHANTABILITY AND FITNESS FOR A PARTICULAR PURPOSE ARE DISCLAIMED. IN NO EVENT SHALL THE COPYRIGHT HOLDER OR CONTRIBUTORS BE LIABLE FOR ANY DIRECT, INDIRECT, INCIDENTAL, SPECIAL, EXEMPLARY, OR CONSEQUENTIAL DAMAGES (INCLUDING, BUT NOT LIMITED TO, PROCUREMENT OF SUBSTITUTE GOODS OR SERVICES; LOSS OF USE, DATA, OR PROFITS; OR BUSINESS INTERRUPTION) HOWEVER CAUSED AND ON ANY THEORY OF LIABILITY, WHETHER IN CONTRACT, STRICT LIABILITY, OR TORT (INCLUDING NEGLIGENCE OR OTHERWISE) ARISING IN ANY WAY OUT OF THE USE OF THIS SOFTWARE, EVEN IF ADVISED OF THE POSSIBILITY OF SUCH DAMAGE.