

# ZABER

X-MCC3 Universal Motor Controller  
Connectors and Indicators

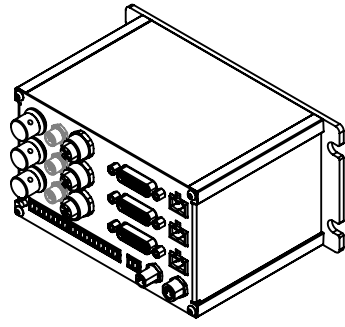

Model Number*	Encoder Output Connector
X-MCC3	None
X-MCC3-T7	M5 female, 4-pin
X-MCC3-T8	M8 male, 8-pin
X-MCC3-T15	M8 male, 8-pin
X-MCC3-T16	M8 male, 8-pin

\*See product page for complete list of available models at [www.zaber.com](http://www.zaber.com)

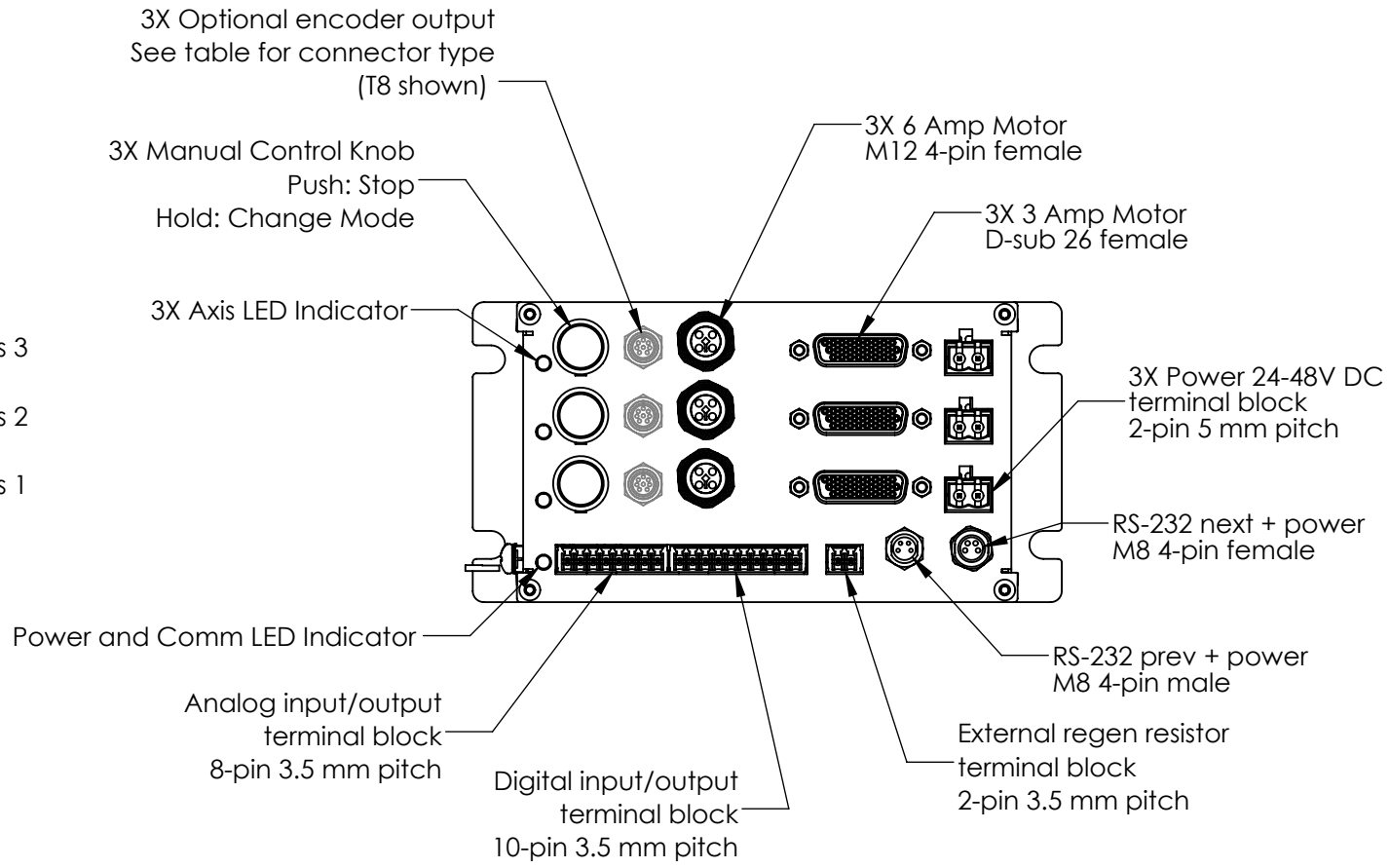
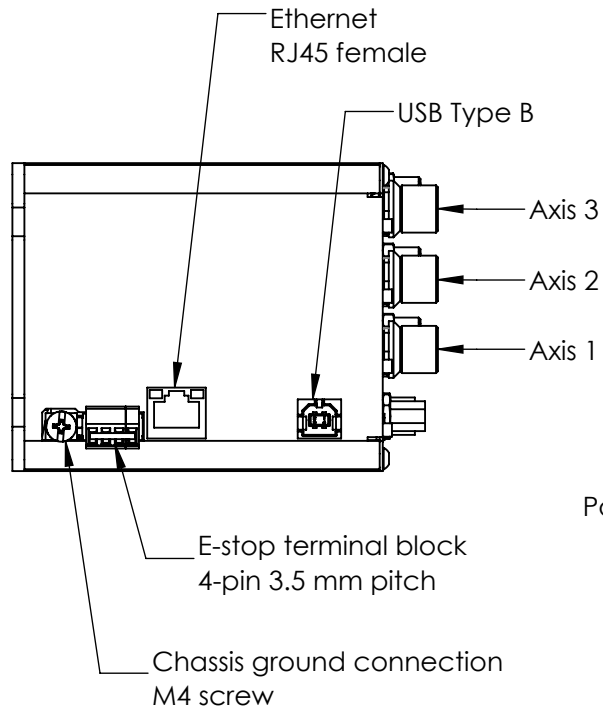

# ZABER

X-MCC3 Universal Motor Controller  
dimensions in mm

