

ZABER

X-MCC4 Universal Motor Controller
Connectors and Indicators

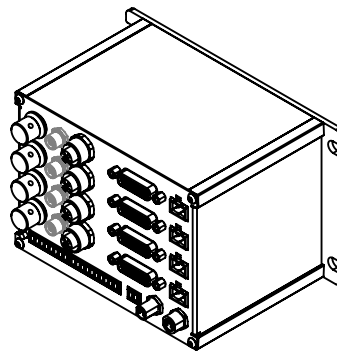

Model Number*	Encoder Output Connector
X-MCC4	None
X-MCC4-T7	M5 female, 4-pin
X-MCC4-T8	M8 male, 8-pin
X-MCC4-T15	M8 male, 8-pin
X-MCC4-T16	M8 male, 8-pin

*See product page for complete list of available models at www.zaber.com

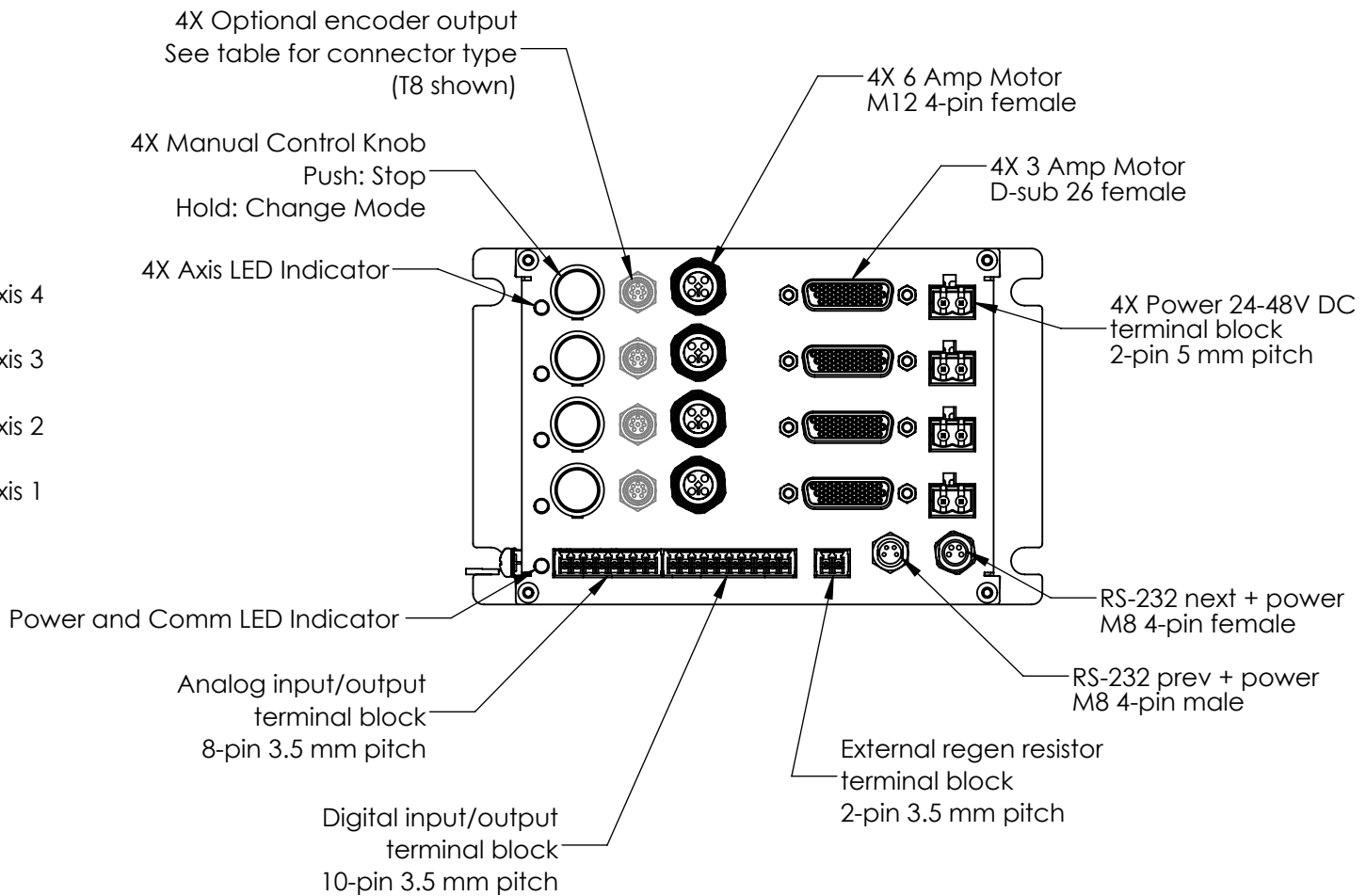
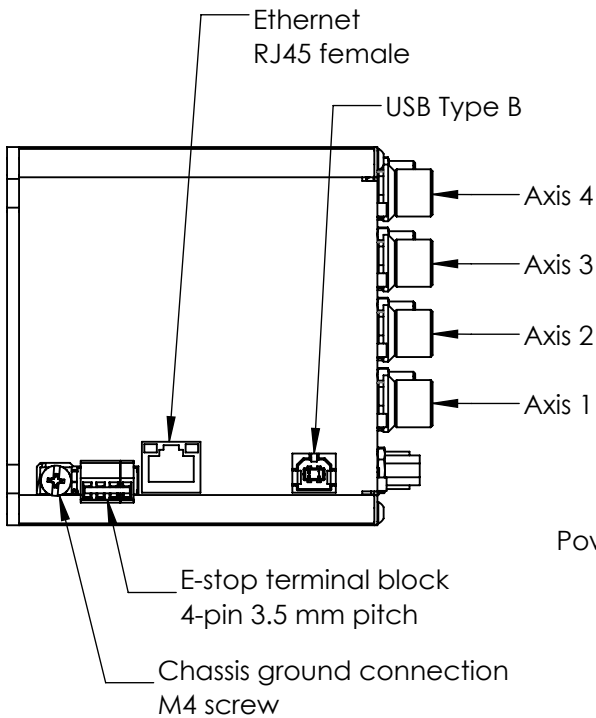

ZABER

X-MCC4 Universal Motor Controller
dimensions in mm

