

X-RSB120AU Datasheet

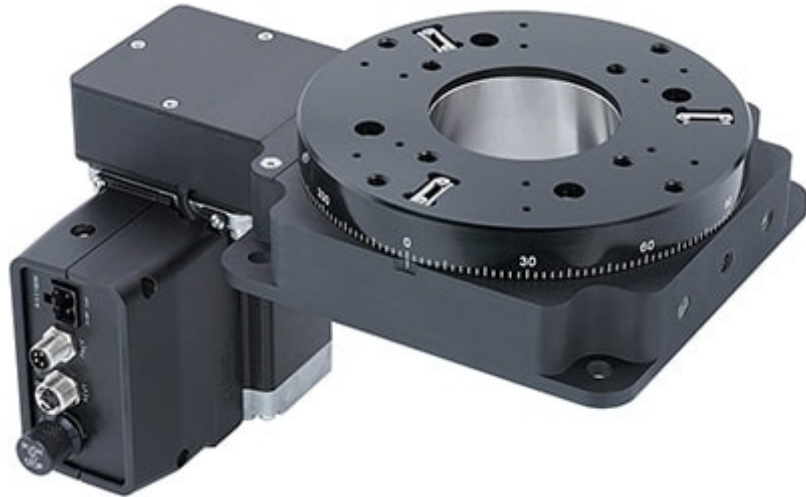

- Speeds up to 1,200 rpm
- Continuous 360° rotation stage
- Multiple motor configurations
- Built-in controller; daisy-chains with other Zaber products

X-RSB Series Overview

Zaber's X-RSB Series rotation stages feature a compact footprint, low profile, and a load capability of up to 50 kg. With a maximum speed of 1,200 rpm, these rotation stages are ideal for the rapid positioning of light loads to within a fraction of a degree.

They are stand-alone units requiring either a standard 24 V or 48 V power supply. There are two motor configurations available: up and down. Motor up configurations allow flush mounting of the device to a flat surface, and motor down configurations allow for a full 360° movement of loads that extend past the edge of the stage top. An indexed knob provides convenient manual control for versatile operation even without a computer.

These stages connect to the RS-232 port or USB port of any computer, and they can be daisy-chained with any other Zaber products. The daisy-chain also shares power, making it possible for multiple X-Series products to share a single power supply. Convenient locking, 4-pin, M8

connectors on the unit allow for secure connection between units. Like all of Zaber's products, the X-RSB Series is designed to be 'plug and play' and very easy to set up and operate.

For more information visit: <https://www.zaber.com/products/rotary-stages/X-RSB>

X-RSB Series Part Numbering & Options

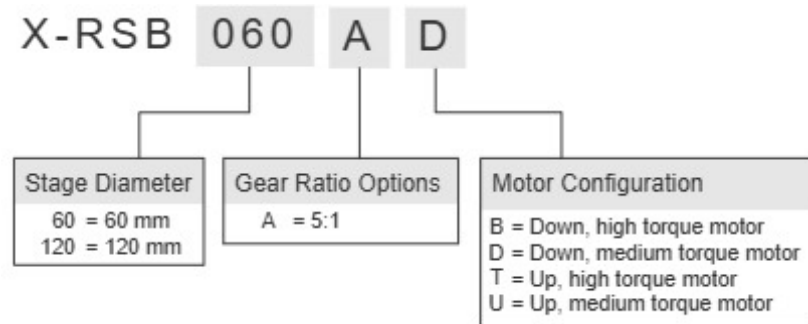

X-RSB120AU Drawings

- [X-RSB120_D&U_configs.png](#) (Drawing for the X-RSB120 D&U configs)

X-RSB120AU Specifications

Microstep Size (Default Resolution)	0.005625° (98.173 μrad)
Built-in Controller	Yes
Range	360°
Accuracy (unidirectional)	0.28° (4.886000 mrad)
Repeatability	< 0.001° (< 0.017 mrad)
Backlash	< 0.25° (< 4.362 mrad)
Maximum Speed	3000°/s (500 rpm)
Minimum Speed	0.003434°/s (59.934 μrad/s)
Speed Resolution	0.003434°/s (59.934 μrad/s)
Encoder Type	No
Communication Interface	RS-232
Communication Protocol	Zaber ASCII (Default), Zaber Binary
Data Cable Connection	Locking 4-pin M8
Maximum Continuous Torque	250 N-cm (354.0 oz-in)
Maximum Centered Load	500 N (112.1 lb)
Maximum Moment (Transverse)	2000 N-cm (2832.2 oz-in)
Stage Top Dimension	120 mm (4.724")
Radial Error Motion	+/- 3 μm (+/- 0.000118")
Axial Error Motion	< 3 μm (< 0.000118")
Tilt Error Motion	+/- 0.0014° (+/- 24.43 μrad)
Bearing Plane Offset	20 mm (0.787")
Power Supply	24 - 48 VDC
Power Plug	2-pin Screw Terminal
Maximum Current Draw	2000 mA
Angular Motion Per Motor Rev	72°
Motor Steps Per Rev	200
Motor Type	Stepper (2-phase)
Motor Rated Current	2100 mA/phase
Inductance	7.2 mH/phase
Default Resolution	1/64 of a step
Mechanical Drive System	Synchronous belt

Microstep Size (Default Resolution)	0.005625° (98.173 μrad)
Limit or Home Sensing	Magnetic home sensor
Manual Control	Yes
Axes of Motion	1
LED Indicators	Yes
Mounting Interface	Kinematic with M2.5 and M6 threaded holes
Operating Temperature Range	0 - 50 °C
CE Compliant	Yes
Vacuum Compatible	No
Weight	2.04 kg (4.497 lb)

X-RSB Series Charts

Torque Speed Performance

48V

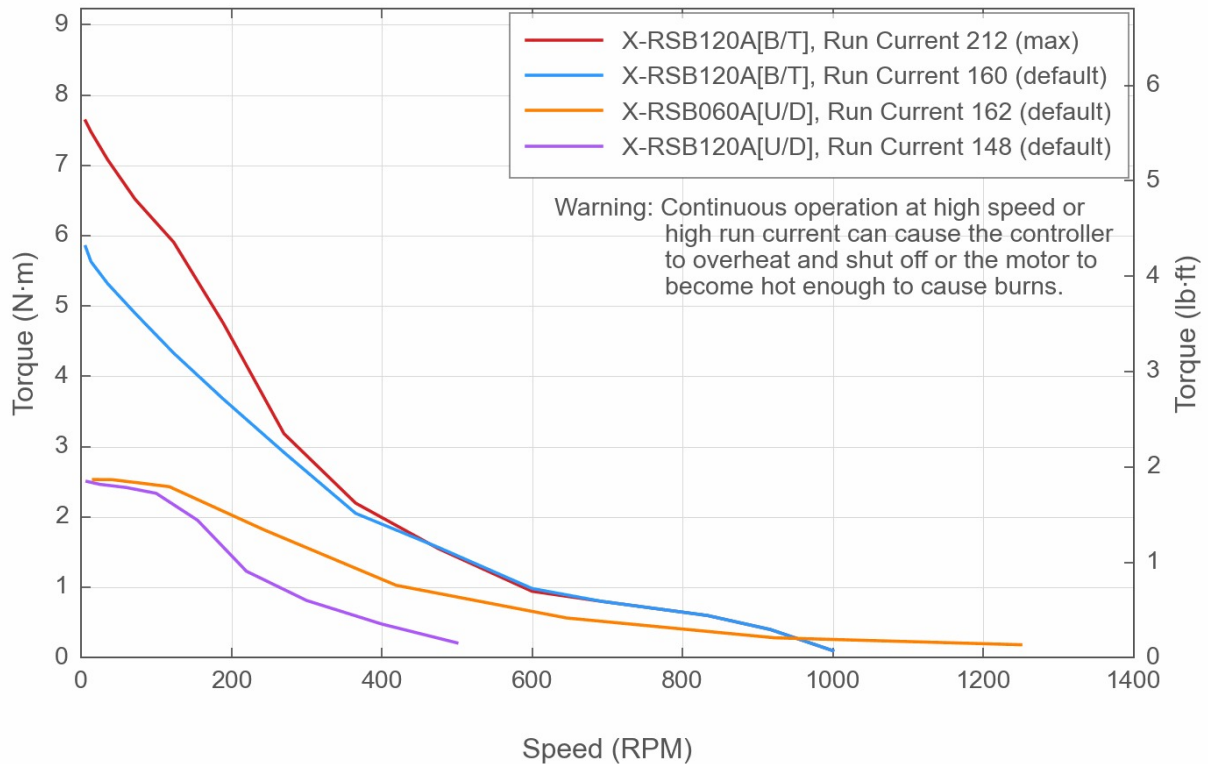

Typical Accuracy

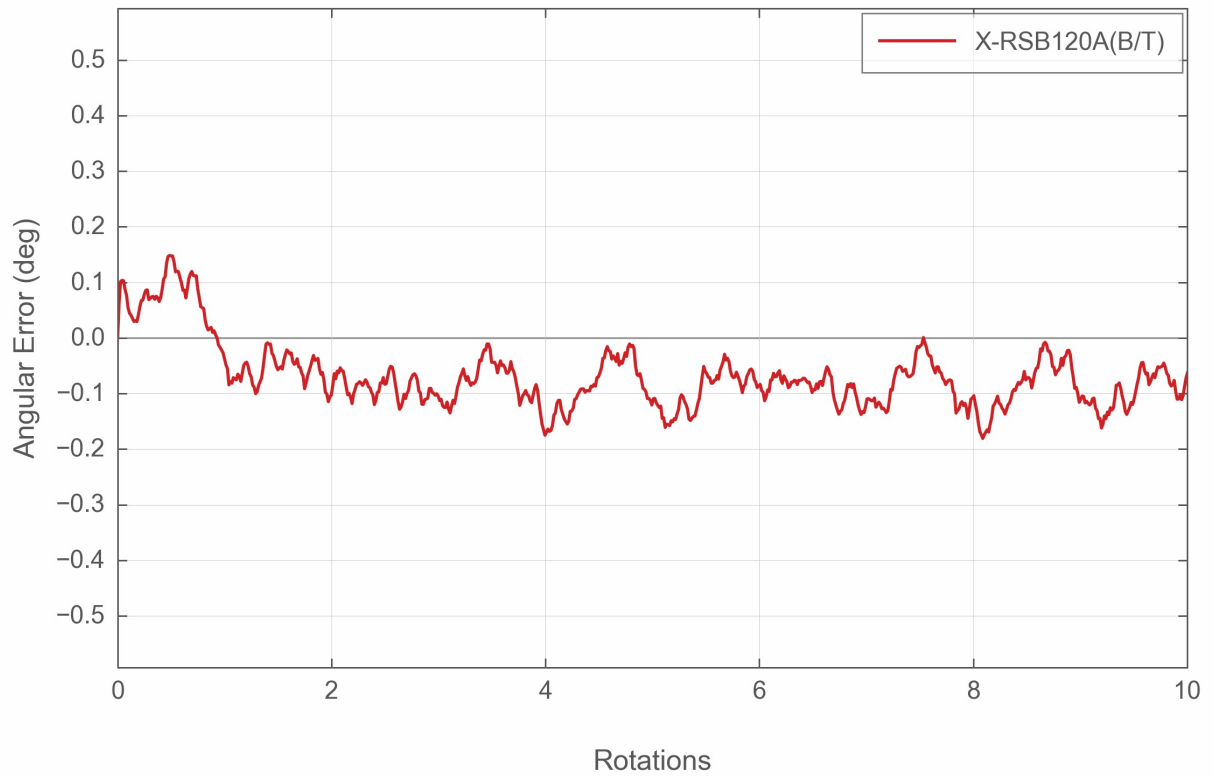

Angular Acceleration

48V, Default Run Current

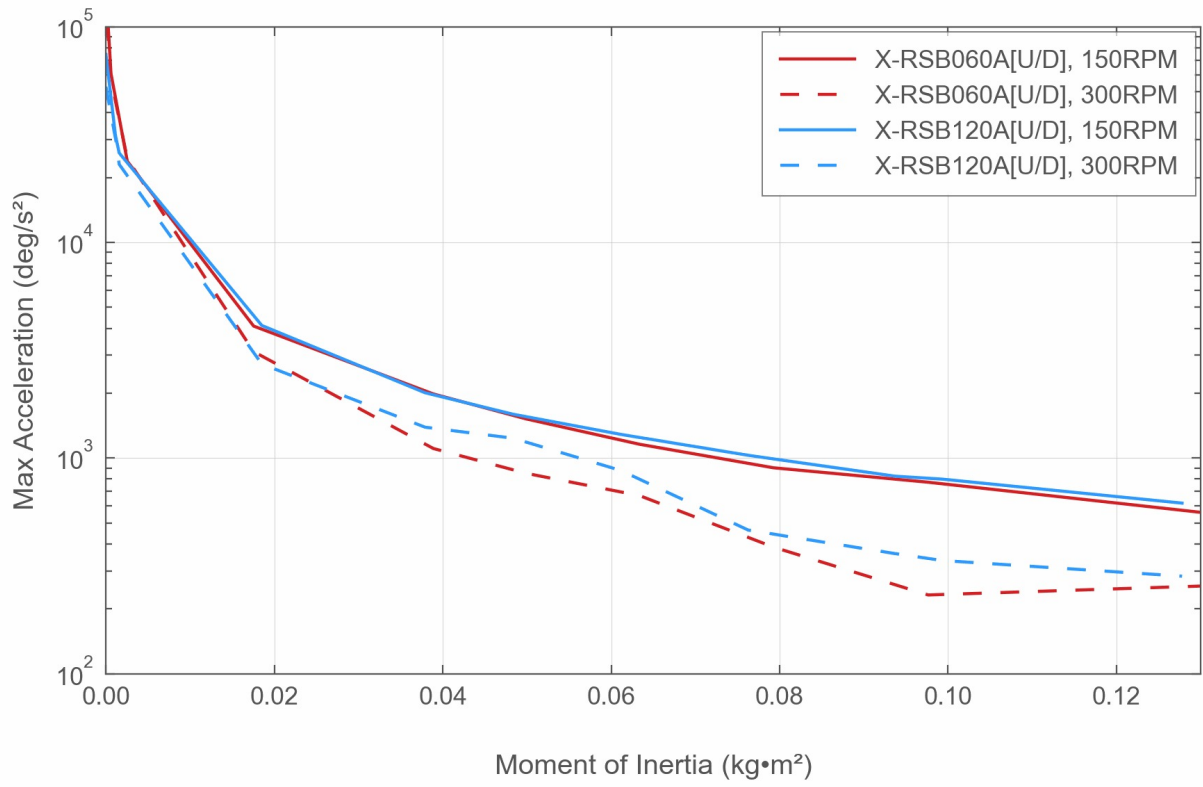

Angular Acceleration

48V, Run Current 212 (max)

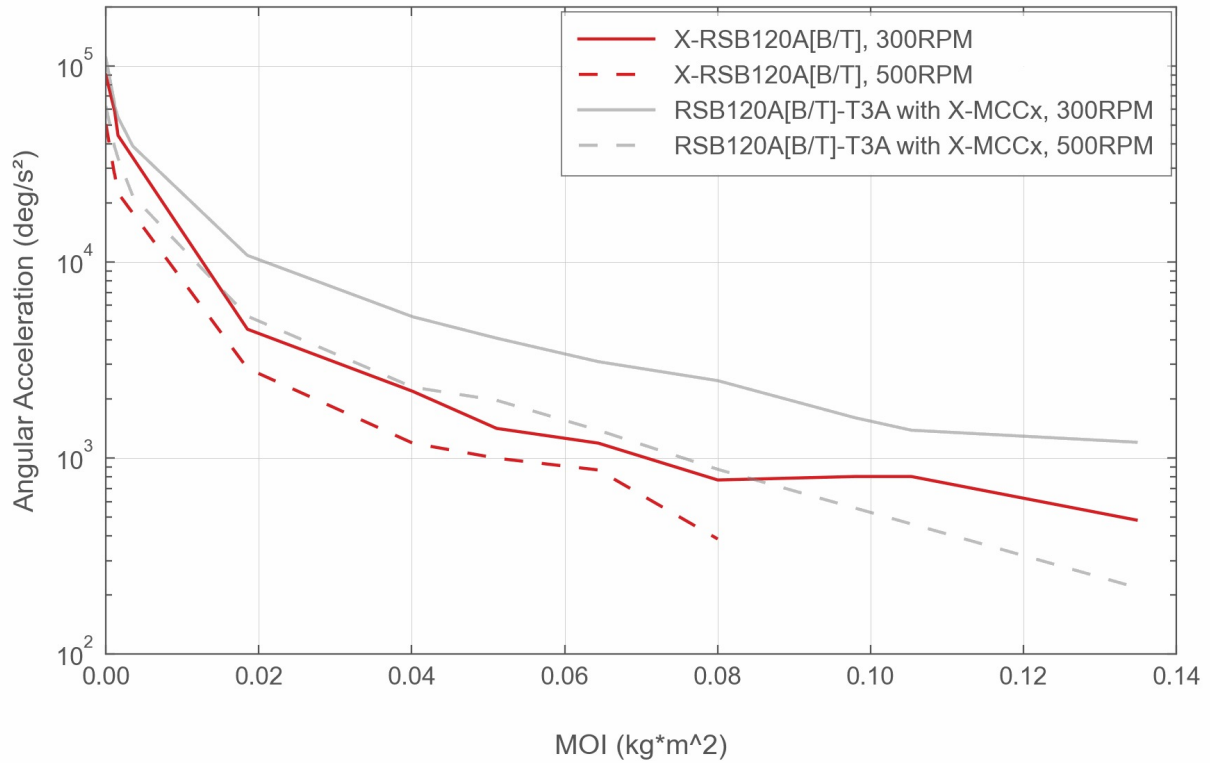

Contact

Email: contact@zaber.com

Phone (toll free Canada/USA): 1-888-276-8033

Phone (direct): 1-604-569-3780

Fax: 1-604-648-8033

Zaber Technologies Inc.

#2 - 605 West Kent Ave. N.

Vancouver, British Columbia

Canada, V6P 6T7

<https://www.zaber.com>