

# ZABER

## X-NMS17 Stepper Motor with Built-in Controller

dimensions in mm

See product page for complete list of available models at [www.zaber.com](http://www.zaber.com)

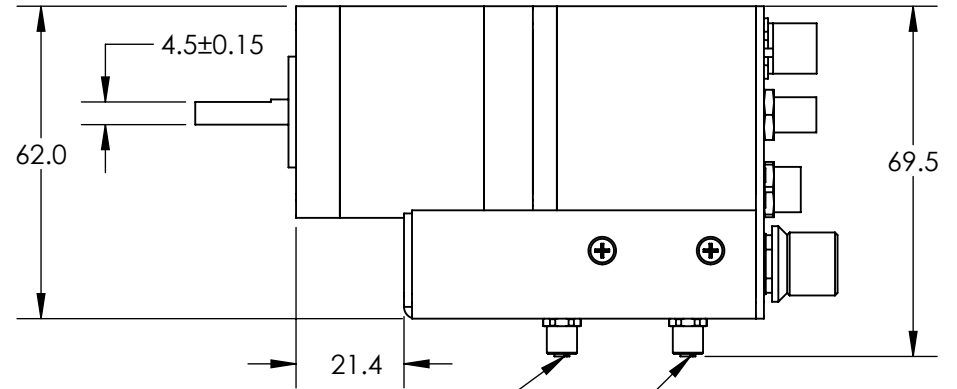
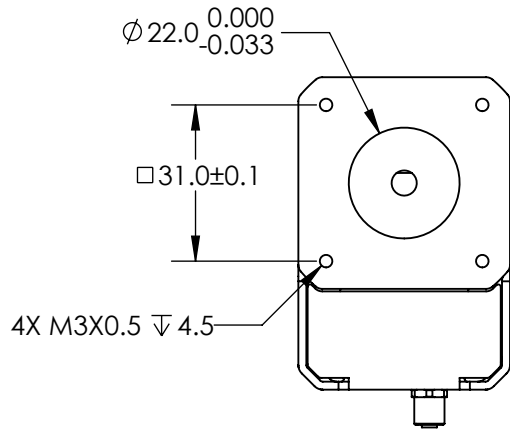
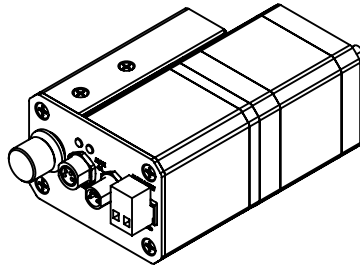

Away sensor  
M5 4 pin female

Home sensor  
M5 4 pin female

RS-232 next + power  
M8 4 pin female

LEDs

RS-232 prev + power  
M8 4 pin male

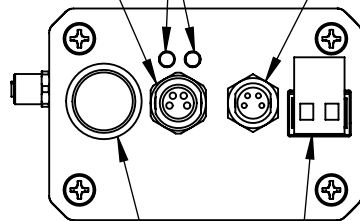

Indexed speed or  
position control knob

Power 24-48V terminal block  
2 pin 5 mm pitch

